

NOTES ON REVISION DATED 1-5-96

This revision of the Commuter Rail Book of Standard Plans - Track and Roadway, dated January 5, 1996 revises a total of 28 existing plans and adds 4 new drawings. Plan holders of existing Book of Standard Plans current to the revision dated 10-28-92 are hereby directed to replace the existing index and revised plans as noted on the attached summary of plans revised and add the four new drawings in proper numerical order.

In addition to minor corrections and additions, the revisions to turnouts are primarily concerned with adding 1:80 cant transition tie plates between the flat plates in the switch and frog area and the standard 1:40 cant plates used in the closure area and either side of the turnout as well as revisions to the swivel shoulder tie plates used in the frog area. A longer 35" swivel shoulder plate has been added and the schedule of other plates revised.

A new drawing for the 1:80 transition plates has been added as well as three new drawings for a number 8 double slip switch. The double slip switch plans are generic in nature, defining only the basic layout and dimensions of major components to facilitate standardization of components for replacement.

There are still two turnout designs in the standards. The original design which uses solid heel blocks is retained. There are also floating heel block designs with 60 foot undercut stock rails and bonded insulated joint plug rails for the number 10, 15, & 20 turnouts. These turnouts are identified as "Floating Heel Block" turnouts to distinguish them from the original design. Unless otherwise specified, the floating heel block turnouts shall be furnished with any new orders. The original design of 1986 will be used only for replacement of material or certain specific applications when approved by Railroad Operations.

Many of the turnout detail plans such as vertical switch rods, switch plates and frogs are common to both turnout designs. The original plans for those elements have been

modified to allow their use with either design.

As an aid to finding the various turnouts, an explanation of the plan numbering system may be helpful. Special trackwork and related material are numbered in the 2000 series. The two middle numbers denote the frog number of the original design turnout: that is, 2080, 2100, 2150 and 2200 number series are for number 8, 10, 15 & 20 turnouts respectively. The newer design, which is a revision of the original, adds one to the middle number so that 2110, 2160, 2210 number series indicates the new design for number 10, 15, & 20 turnouts. As noted in the paragraph above, the plans of details such as switch plates, switch rods and frogs are common to both turnout designs.

MASSACHUSETTS BAY TRANSPORTATION AUTHORITY
BOOK OF STANDARD PLANS - TRACK AND ROADWAY

PLANS REVISED IN APRIL 29, 1996 REVISION

REVISED STANDARD PLANS

1030 -	Asphalt Underlayment at Turnouts
1110 -	Headblock Tie Layout & Dapping Details
2200 -	No. 20 Turnout - Bill of Material
2202 -	No. 20 Welded Turnout Tie and Rail Layout
2203 -	No. 20 Equilateral Turnout Tie and Rail Layout
2204 -	No. 20 Crossover Tie and Rail Layout
2205 -	39'-0" Curved Split Switch
2209 -	Typical Power Switch Layout with Helper
2210 -	No. 20 Turnout with Floating Heel Blocks - Bill of Material
2212 -	No. 20 Turnout with Floating Heel Blocks - Tie & Rail Layout
2215 -	39' Curved Split Switch with Floating Heel Blocks

Above plans have been revised to change two elements of the number 20 turnouts as follows:

- Changed headblock timbers on number 20 turnouts from 12' long to 14' long. The added length will allow fastening the switch helper mechanism used on the 39' switches further in from the end of the headblock.
- Added four 17'- 0" switch timbers at heel end of turnout to allow placing concrete ties at end of turnout without interlacing or re-spacing of ties. Note: If Oak switch timbers are used rather than tropical hardwood (Azobe), transition ties should be used between last long timber of turnout and and concrete ties.

To make your Book of Standard Plans current, please replace the above plans as well as the entire Plan Index with the revised index attached and dated April 29, 1996

There are still two turnout designs in the standards. The original design which uses solid heel blocks is retained. There are also floating heel block designs with 60 foot undercut stock rails and bonded insulated joint plug rails for the number 10, 15, & 20 turnouts. These turnouts are identified as "Floating Heel Block" turnouts to distinguish them from the original design. Unless otherwise specified, the floating heel block turnouts shall be furnished with any new orders. The original design of 1986 will be used only for replacement of material or certain specific applications when approved by Railroad Operations.

Many of the turnout detail plans such as vertical switch rods, switch plates and frogs are common to both turnout designs. The original plans for those elements have been modified to allow their use with either design.

As an aid to finding the various turnouts, an explanation of the plan numbering system may be helpful. Special track work and related material are numbered in the 2000 series. The two middle numbers denote the frog number of the original design turnout: that is, 2080, 2100, 2150 and 2200 number series are for number 8, 10, 15 & 20 turnouts respectively. The newer design, which is a revision of the original, adds one to the middle number so that 2110, 2160, 2210 number series indicates the new design for number 10, 15, & 20 turnouts. As noted in the paragraph above, the plans of details such as switch plates, switch rods and frogs are common to both turnout designs.

MBTA - RAILROAD OPERATIONS INDEX - STANDARD PLANS

<u>DRAWING NO.</u>	<u>TITLE</u>	<u>ISSUE NO.</u>	<u>ISSUE DATE</u>	<u>DRAWING NO.</u>	<u>TITLE</u>	<u>ISSUE NO.</u>	<u>ISSUE DATE</u>
<u>ROADWAY & CLEARANCES</u>							
1000	Typical Roadbed Section - Double & Single Track on Tangent	2	10-28-92	1110	Headblock Tie Layout & Dapping Details	3	4-29-96
1002	Typical Roadbed Section - Double & Single Track on Curve	2	10-28-92	1120	Concrete Tie	2	10-28-92
1012	Standard Clearances - General Roadway Obstructions-Tangent Track	2	10-28-92	1200	Wood Shims for Tie Plates	1	10-28-92
1013	Standard Clearances at Stations - Tangent Track	1	10-28-92	1204	Frost Bracing and Blocking	1	10-28-92
1014	Standard Clearances - Tangent Track - Signal Equipment and Utility Crossings	3	1-5-96	1210	Cut Spike	2	10-28-92
1015	Clearances for New Overhead Bridges	1	10-28-92	1214	Timber Drive Spikes	1	10-28-92
1016	Minimum Vertical Clearances by Route Segments	1	10-28-92	1216	Lock Spike for Tie Plates	2	10-28-92
1017	Standard Clearances - Tangent Track Bridges	1	10-28-92	1217	Track Drive Spike	1	10-28-92
1018	Standard Track Centers & Side Clearance Increases for Curved Track	2	10-28-92	1218	Screw Spikes	1	10-28-92
1019	Clearance at Passenger Platforms	1	10-28-92	1220	Tie Plate for 115 LB RE Rail	2	10-28-92
1020	Side Track Installation	1	10-28-92	1222	Tie Plate for 132 LB RE Rail	2	10-28-92
1030	Asphalt Underlayment at Turnouts	3	2-29-96	1224	Resilient Fastener Tie Plate for Lock Spikes	2	10-28-92
<u>TIES, TIE PLATES & FASTENERS</u>							
1100	Standard Timber Tie	1	10-28-92	1225	Resilient Fastener Tie Plate for Screw Spikes	1	10-28-92
1104	Tie Spacing and Spiking Patterns	2	1-5-96	1230	Spiking Arrangement for Tie Plates	2	10-28-92
1106	Anti-Splitting End Plate for Cross Ties & Switch Timber	2	10-28-92	1232	Rail Anchoring Details - Jointed and CWR Track	1	10-28-92
1108	Transition Ties	1	10-28-92	1236	Bridge Timber Anchoring Detail	2	1-5-96
				<u>RAIL AND JOINT BARS</u>			
				1300	115 LB RE Rail	2	10-28-92
				1302	132 LB RE Rail	2	10-28-92
				1320	115 LB RE Joint Bar	2	10-28-92
				1322	132 LB RE Joint Bar	2	10-28-92
				1328	Compromise Joint Bars for Tee Rail	2	10-28-92
				1332	Standard Track Bolt	1	10-28-92
				1340	132 RE Bonded, Insulated Joint	2	10-28-92

<u>DRAWING NO.</u>	<u>TITLE</u>	<u>ISSUE NO.</u>	<u>ISSUE DATE</u>
<u>TURNOUTS AND CROSSOVERS</u>			
2000	Standard Turnouts - General Layout	2	10-28-92
2002	Standard Crossovers - General Layout	2	10-28-92
2080	<u>No. 8 Turnout</u> - Bill of Material	3	1-5-96
2081	Offsets for No. 8 Turnout	1	10-28-92
2082	No. 8 Welded Turnout - Tie and Rail Layout	3	1-5-96
2083	No. 8 Crossover - Tie and Rail layout	2	10-28-92
2084	No. 8 Railbound Manganese Steel Frog	3	1-5-96
2100	<u>No. 10 Turnout</u> - Bill of Material	2	10-28-92
2101	Offsets for No. 10 Turnout	1	11-17-86
2102	No. 10 Welded Turnout - Tie and Rail Layout	2	10-28-92
2103	No. 10 Crossover - Tie and Rail Layout	2	10-28-92
2104	16'-6" Straight Split Switch	3	1-5-96
2105	No. 10 Railbound Manganese Steel Frog	3	1-5-96
2106	Switch Plates and Gage Plates - For 16'-6" Switch	2	10-28-92
2107	Vertical Switch Rods and Adjustable Rocker Clips - For 16'-6" Switch	2	10-28-92
2110	<u>No. 10 Turnout with Floating Heel Blocks</u> - Bill of Material	2	1-5-96
2112	No. 10 Turnout with Floating Heel Blocks - Tie & Rail Layout	2	1-5-96
2114	16'-6" Straight Split Switch with Floating Heel Blocks	2	1-5-96
2150	<u>No. 15 Turnout</u> - Bill of Material	2	10-28-92
2151	Offsets for No. 15 Turnout	2	10-28-92
2152	No. 15 Welded Turnout - Tie and Rail Layout	2	10-28-92
2153	No. 15 Equilateral Turnout - Tie and Rail Layout	2	10-28-92
2154	No. 15 Crossover - Tie and Rail Layout	2	10-28-92

<u>DRAWING NO.</u>	<u>TITLE</u>	<u>ISSUE NO.</u>	<u>ISSUE DATE</u>
2155	26'-0" Curved Split Switch	2	10-28-92
2156	No. 15 Railbound Manganese Steel Frog	3	1-5-96
2157	Switch Plates and Gage Plates - For 26'-0" Switch	3	1-5-96
2158	Vertical Switch Rods and Adjustable Rocker Clips - for 26'-0" Switch	2	10-28-92
2160	<u>No. 15 Turnout with Floating Heel Blocks</u> - Bill of Material	2	1-5-96
2162	No. 15 Turnout with Floating Heel Blocks - Tie and Rail Layout	2	1-5-96
2165	26'-0" Curved Split Switch with Floating Heel Blocks	2	1-5-96
2200	<u>No. 20 Turnout</u> - Bill of Material	3	4-29-96
2201	Offsets for No. 20 Turnout	2	10-28-92
2202	No. 20 Welded Turnout - Tie and Rail Layout	3	4-29-96
2203	No. 20 Equilateral Turnout - Tie and Rail Layout	3	4-29-96
2204	No. 20 Crossover - Tie and Rail Layout	3	4-29-96
2205	39'-0" Curved Split Switch	3	4-29-96
2206	No. 20 Railbound Manganese Steel Frog	3	1-5-96
2207	Switch Plates and Gage Plates - For 39'-0" Switch	2	10-28-92
2208	Vertical Switch Rods and Adjustable Rocker Clips - for 39'-0" Switch	2	10-28-92
2209	Typical Power Switch Layout with Helper	3	4-29-96
2210	<u>No. 20 Turnout with Floating Heel Blocks</u> - Bill of Material	3	4-29-96
2212	No. 20 Turnout with Floating Heel Blocks - Tie and Rail Layout	3	4-29-96
2215	39'-0" Curved Split Switch with Floating Heel Blocks	3	4-29-96
<u>MISCELLANEOUS TURNOUT COMPONENTS</u>			
2300	10'-0" Manganese Steel One Piece Guard Rail	2	10-28-92

<u>DRAWING NO.</u>	<u>TITLE</u>	<u>ISSUE NO.</u>	<u>ISSUE DATE</u>
2302	13'-3" Manganese Steel One Piece Guard Rail	1	10-28-92
2310	Guard Rail Installation and Maintenance	2	10-28-92
2326	Frog Tie Plates - Railbound Manganese Frog	2	10-28-92
2328	Self-Aligning Shoulder Tie Plates	2	1-5-96
2340	Resiliently Fastened Turnout Plates - For Use Behind Heel of Switch with Graduated Risers	2	10-28-92
2341	Table of Dimensions for Resiliently Fastened Turnout Plates with Graduated Risers	2	10-28-92
2342	Resiliently Fastened Turnout Plates No. 8 & 10 Floating Heel Block Turnouts	2	1-5-96
2343	Resiliently Fastened Turnout Plates No. 15 & 20 Floating Heel Block Turnouts	2	1-5-96
2348	Special Flat and Transition Canted Plates	1	1-5-96
2350	Heel Block and Switch Rail Stop - 13', 16'-6", 26' & 39' Switches	2	10-28-92
2352	Resiliently Fastened Adjustable Rail Brace	2	6-5-87
2356	Switch Point Guard	2	10-28-92
2360	60 Ft. Undercut Stock Rail	1	10-28-92
2370	No. 6 Solid Self-Guarded Manganese Steel Frog	1	10-28-92
2372	No. 8 Solid Self-Guarded Manganese Steel Frog	1	10-28-92
2374	No. 10 Solid Self-Guarded Manganese Steel Frog	1	10-28-92
<u>REPLACEMENT AND MAINTENANCE MATERIAL</u>			
2502	Replacement Bolts for Railbound Manganese Frogs	1	11-17-86
2504	Replacement Bolts for Self-Guarded Frogs	1	11-17-86
2506	B&M No. 6 Railbound Manganese Steel Frog	1	11-17-86
2508	B&M No. 8 Railbound Manganese Steel Frog	1	11-17-86
2510	B&M No. 10 Railbound Manganese Steel Frog	1	11-17-86
2512	B&M No. 12 Railbound Manganese Steel Frog	1	11-17-86
2515	B&M No. 15 Railbound Manganese Steel Frog	1	11-17-86

<u>DRAWING NO.</u>	<u>TITLE</u>	<u>ISSUE NO.</u>	<u>ISSUE DATE</u>
2520	B&M No. 20 Railbound Manganese Steel Frog	1	11-17-86
2530	B&M Solid Manganese Steel Self Guarded Frogs	1	11-17-86
2540	B&M Hook Flange Guard Rails	1	11-17-86
<u>DOUBLE SLIP SWITCHES AND RAIL CROSSINGS</u>			
2602	No. 8 Double Slip/Rigid Frog, Tie Layout	1	1-5-96
2604	No. 8 Double Slip/Rigid Frog, General Layout	1	1-5-96
2605	No. 8 Double Slip/Rigid Frog, Solid Manganese Center Frog	1	1-5-96
<u>MISCELLANEOUS TRACK AND APPURTENANCES DETAILS</u>			
3000	Hinged Block Derail	1	10-28-92
3004	Sliding Block Derail	2	1-5-96
3006	Split Switch Derail	1	10-28-92
3007	Operating Rod Support Bracket for Split Switch Derail	1	10-28-92
3010	Steel Bumping Post	1	10-28-92
3020-1	New Century Switch Stand - Intermediate, Model 50-B and Low - Model 50-A	2	10-28-92
3020-2	New Century Switch Stand - Intermediate, Model 50-B and Low - Model 50-A	2	10-28-92
3023	Low Switch Stand - Racor - Style 22	2	10-28-92
3030	Switch Stand Target	2	10-28-92
3040	Typical Snowmelter Layout	2	1-5-96
3060	Guard Rail on Bridges	3	1-5-96
3062	Resiliently Fastened Bridge Guard Rail	2	1-5-96
<u>GRADE CROSSINGS</u>			
3100	Grade Crossing Layout	1	10-28-92
3106	Typical Section Full Depth Rubber Crossing	1	10-28-92
3108	Typical Section Rubber Rail Seal Crossing	1	10-28-92
3120	Temporary Timber Grade Crossing	1	10-28-92

<u>DRAWING NO.</u>	<u>TITLE</u>	<u>ISSUE NO.</u>	<u>ISSUE DATE</u>
<u>FENCING</u>			
3200	Snow Fences	1	10-28-92
3204	Inter Track Fence	1	10-28-92
3206	Chain Link Fencing	2	10-28-92
3208	Chain Link Fence Gates	1	10-28-92
<u>SIGNS</u>			
3302	Mile Posts	1	10-28-92
3304	Speed Restrictions, Yard Limit & Flanger Signs	1	11-17-86
3306	Temporary Slow Boards	2	10-28-92
3307	Table of Slow Board Placement Distances	1	10-28-92
3312	Close Clearance Signs	1	11-17-86
3314	Clearance Warning Sign	1	10-28-92
3344	Do Not Dig - Buried Cables	1	11-17-86
3352	No Trespassing Sign	2	10-28-92
3388	Public Crossing, No Warning Devices	1	11-17-86
<u>MISCELLANEOUS</u>			
4056	Steel Beam Guard Rail Detail	1	11-17-86

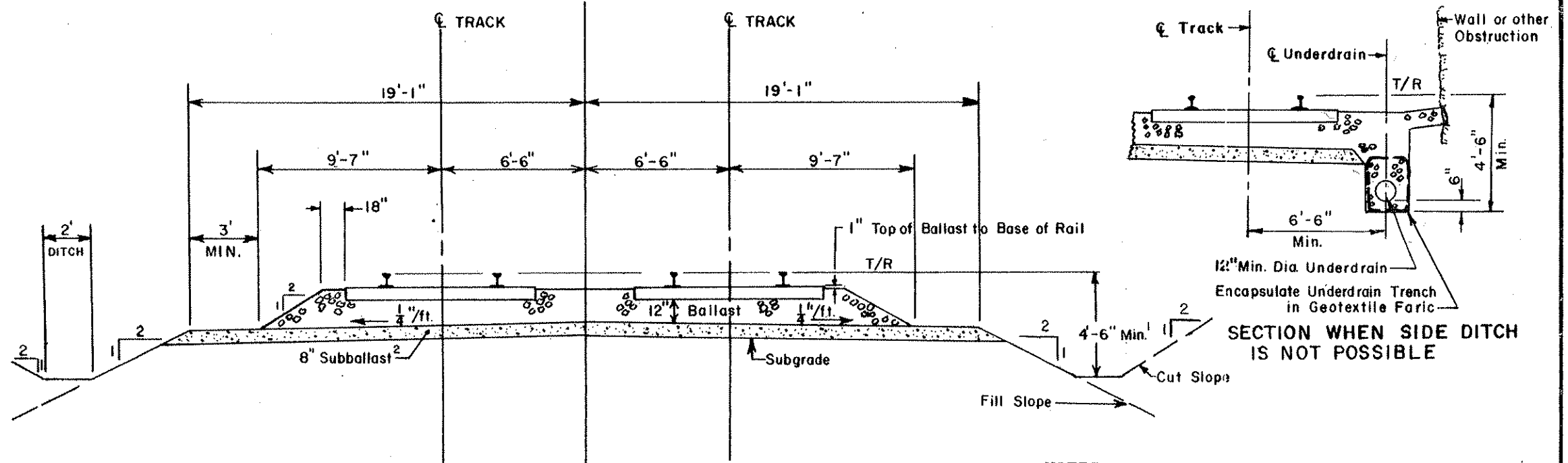

STANDARD SECTION FOR DOUBLE TRACK ON TANGENT

SECTION WHEN SIDE DITCH IS NOT POSSIBLE

NOTES:

1. At locations where sufficient side ditch is not possible, use perforated pipe underdrain (12" min. dia.).
2. In new construction, when subgrade conditions warrant the use of geotextile fabric, place fabric below the subballast.

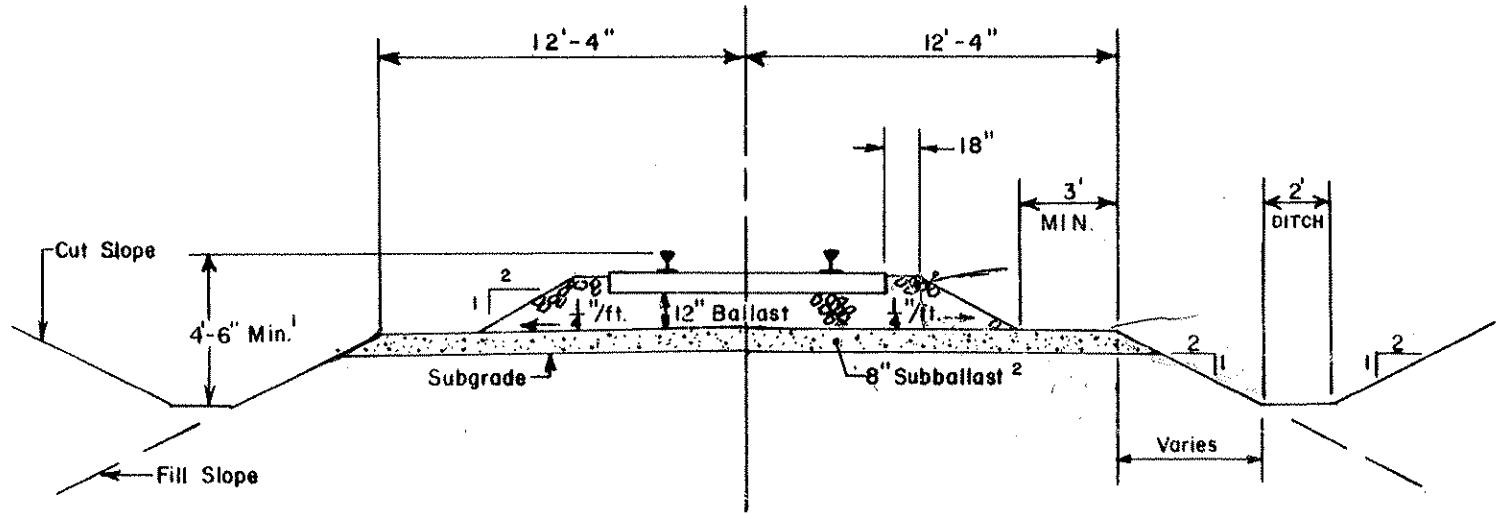

STANDARD SECTION FOR SINGLE TRACK ON TANGENT

T	MASSACHUSETTS BAY TRANSPORTATION AUTHORITY	RAILROAD OPERATIONS	DWG. NO. 1000
			Oct. 28, 1992 (2) ISSUE DATE
TYPICAL ROADBED SECTION DOUBLE & SINGLE TRACK ON TANGENT			
<i>John D. Ray</i> ENGINEERING OFFICER		<i>W. A. Caldwell</i> CHIEF ENGINEERING OFFICER	

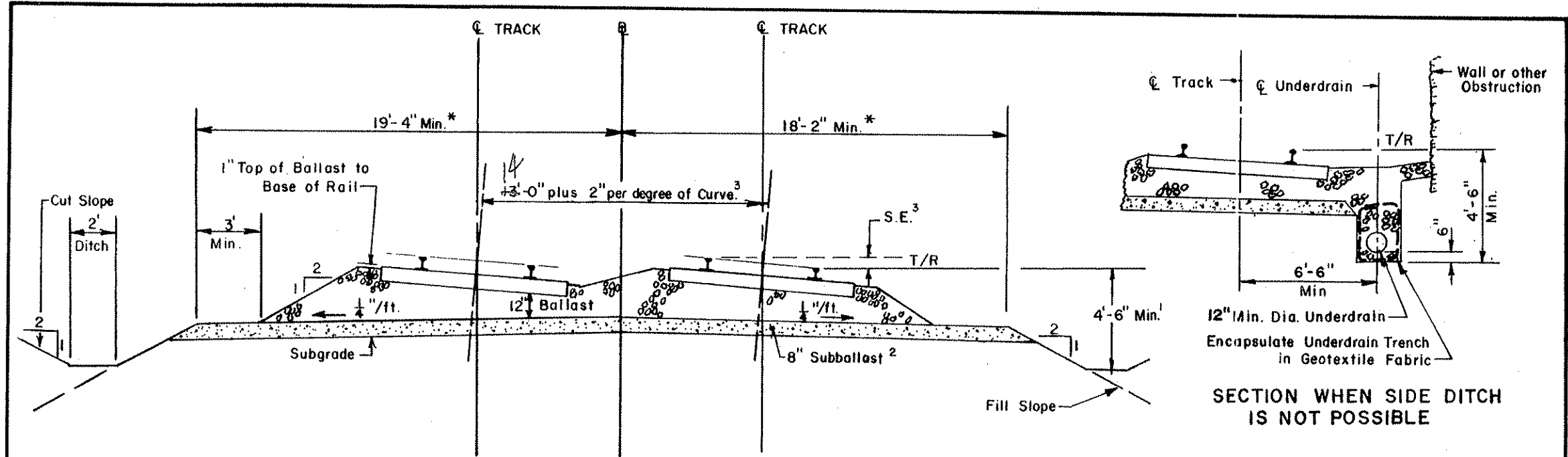

STANDARD SECTION FOR DOUBLE TRACK ON CURVE

SECTION WHEN SIDE DITCH IS NOT POSSIBLE

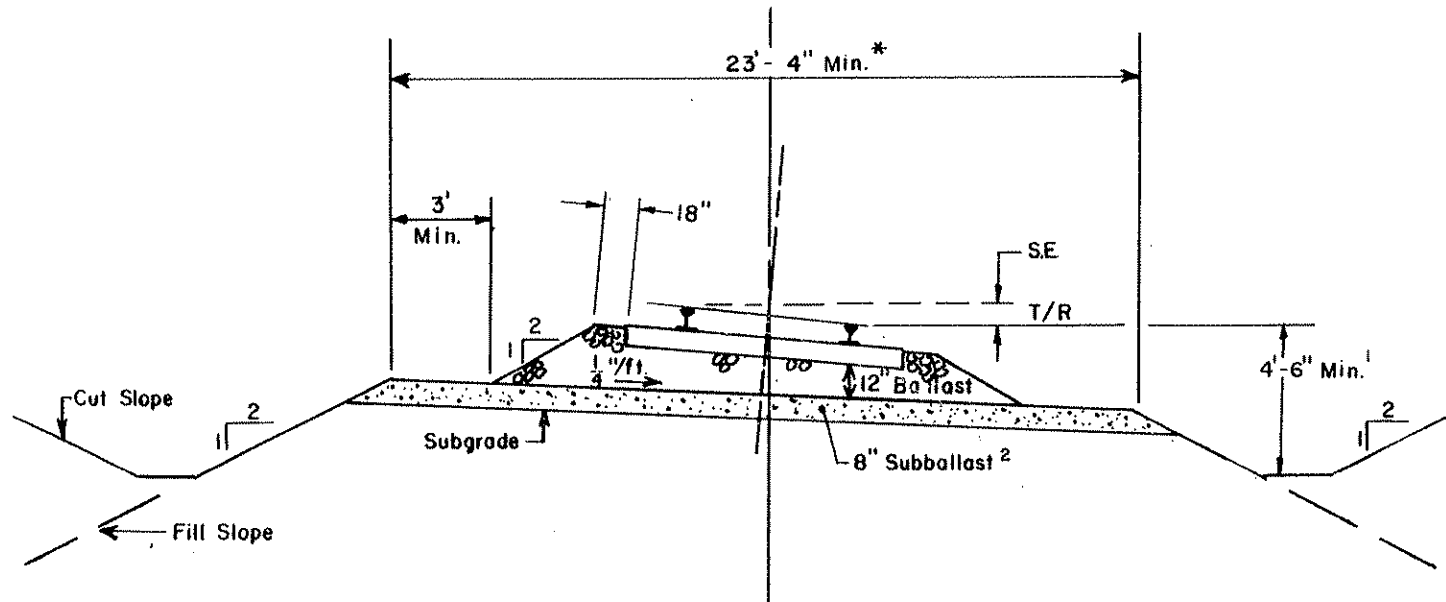

STANDARD SECTION FOR SINGLE TRACK ON CURVE

* Increase these dimensions as necessary to maintain minimum distance of 3' between bottom of ballast shoulder and top of 2:1 Slope.

- At locations where sufficient side ditch is not possible, use perforated pipe underdrain (12" min. dia.).
- In new construction, when subgrade conditions warrant the use of geotextile fabric, place fabric beneath the subballast.
- Wherever the outside track has the greater superelevation, increase the track centers 3 1/2" per 1" of superelevation difference.

	MASSACHUSETTS BAY TRANSPORTATION AUTHORITY	RAILROAD OPERATIONS	DWG. NO. 1002
			Oct. 28, 1992 ISSUE DATE
ENGINEERING OFFICER		CHIEF ENGINEERING OFFICER	

TYPICAL ROADBED SECTION
DOUBLE & SINGLE TRACK ON CURVE

Overhead bridge pier or abutment, retaining walls, and other obstructions including temporary barricades for construction, etc.

Automatic highway crossing devices

1'-6" Min.
10'-0"
Maintenance Rd. (where practical)

8'-6" Min.
12'-0" Preferred

A
15'-0" Preferred
8'-6" Min.

13'-6" Min.

13'-6" Preferred

12'-0" Preferred
8'-6" Min.
20'-0" Max.

7'-0" Min.

Flanger marker, slow board whistle post, etc.

Mile post

STANDARD CLEARANCES - TANGENT TRACK

A-Low switch stand or Electric lock (less than 3'-0" high) ----- 6'-6"
High switch stand (more than 3'-0" high) ----- 9'-0"

T	MASSACHUSETTS BAY TRANSPORTATION AUTHORITY	RAILROAD OPERATIONS	DWG. NO. 1012
			Oct. 28, 1992 (2) ISSUE DATE ISSUE NO.

**STANDARD CLEARANCES
GENERAL ROADWAY OBSTRUCTIONS
TANGENT TRACK**

John D. Ray
ENGINEERING OFFICER

W. A. ...
CHIEF ENGINEERING OFFICER

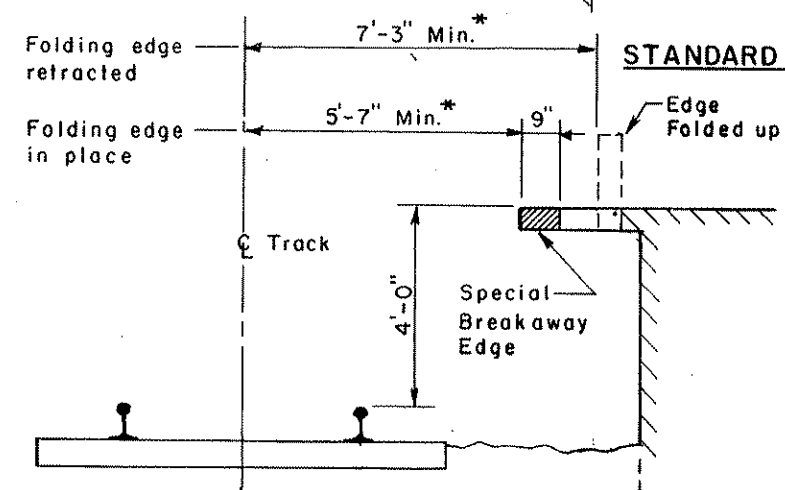
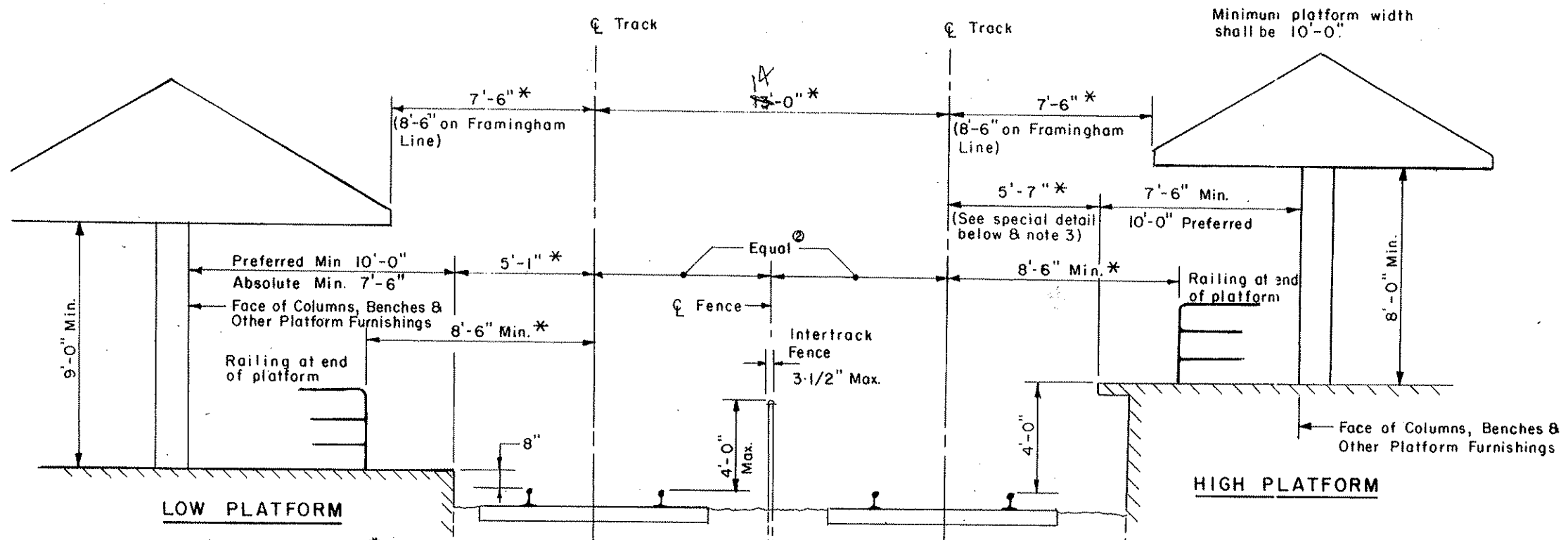

STANDARD CLEARANCES AT PASSENGER STATIONS

NOTES :

1. * Indicates dimensions to be increased for curvature as indicated on Drawings 1018 & 1019.
2. When track centers are less than 13'-0", minimum distance from C of track to face of fence shall be 6'-0".
3. At major terminals with direct fixation and no freight operation, use 5'-4" to high platform.

T MASSACHUSETTS BAY TRANSPORTATION AUTHORITY	RAILROAD OPERATIONS	DWG. NO. 1013
		Oct. 28, 1992
		ISSUE NO. 1

**STANDARD CLEARANCES
AT STATIONS - TANGENT TRACK**

John J. Williams ENGINEERING OFFICER *W. A. ...* CHIEF ENGINEERING OFFICER

SPECIAL HIGH PLATFORM CLEARANCE
Where required by freight operator

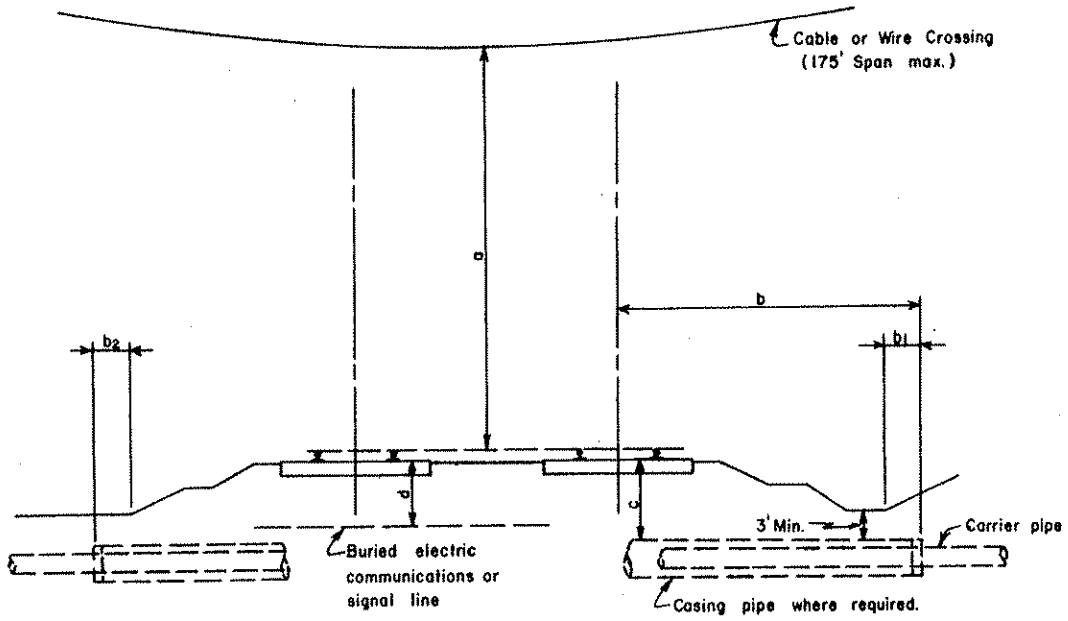

Dimension	Description	Clearance
a	Power lines 0 to 750V	27'-0"
	Power lines 750 to 15,000V	28'-0"
	Power lines 15 to 50 KV	30'-0"
	Other than power lines	27'-0"
b	Sealed ended casings	25'-0"
	Open ended casings	45'-0"
b1	End casing beyond ditch	2'-0"
b2	End casing beyond slope	3'-0"
c	Casing pipe	4'-6"
	Carrier pipe without casing	4'-0"
d	Buried electric lines	4'-0"
	Railroad signal lines	2'-6"
	Communications lines	3'-6"
	Switch Heater Feeds	4'-0"

At 120°F Ambient Temperature

MINIMUM CLEARANCES FOR OVERHEAD & BURIED UTILITY CROSSINGS

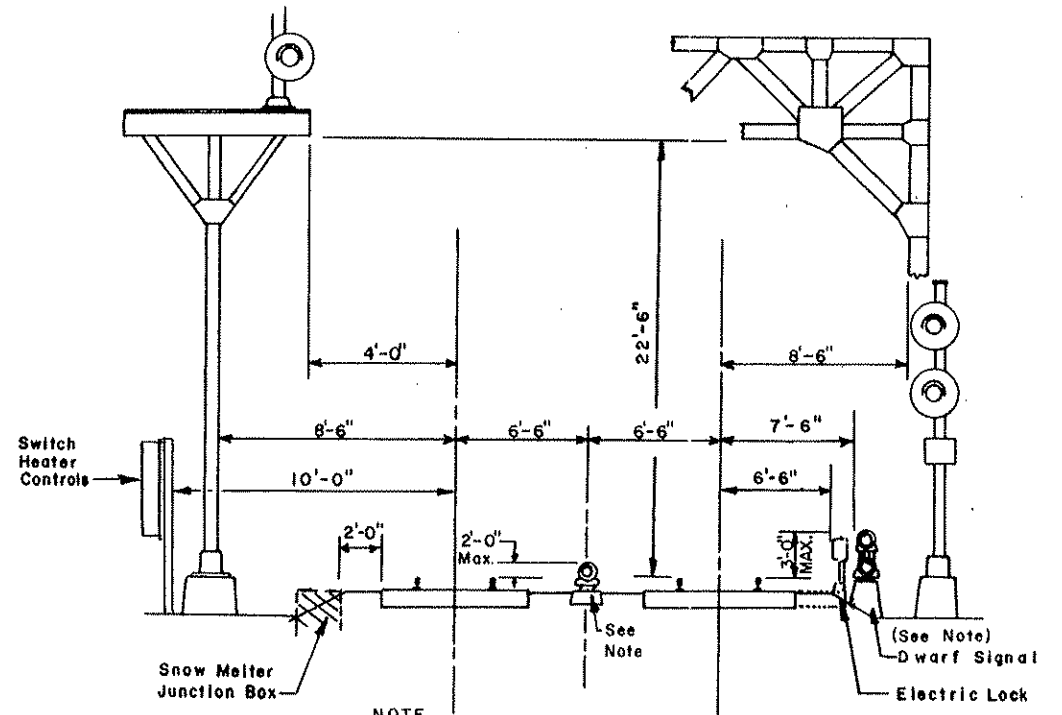

NOTE
Signal Foundations Shall Be Level with Top of Rail Except Dwarf Signals Between Tracks - Foundation to be Level with Top of Ties.

STANDARD CLEARANCE TO SIGNAL EQUIPMENT-TANGENT TRACK

T	MASSACHUSETTS BAY TRANSPORTATION AUTHORITY	RAILROAD OPERATIONS	DWG. NO. 1014
			Jan. 5, 1996 ISSUE DATE
STANDARD CLEARANCES TANGENT TRACK SIGNAL EQUIPMENT & UTILITY CROSSINGS			3 ISSUE NO.
SECTION CHIEF			

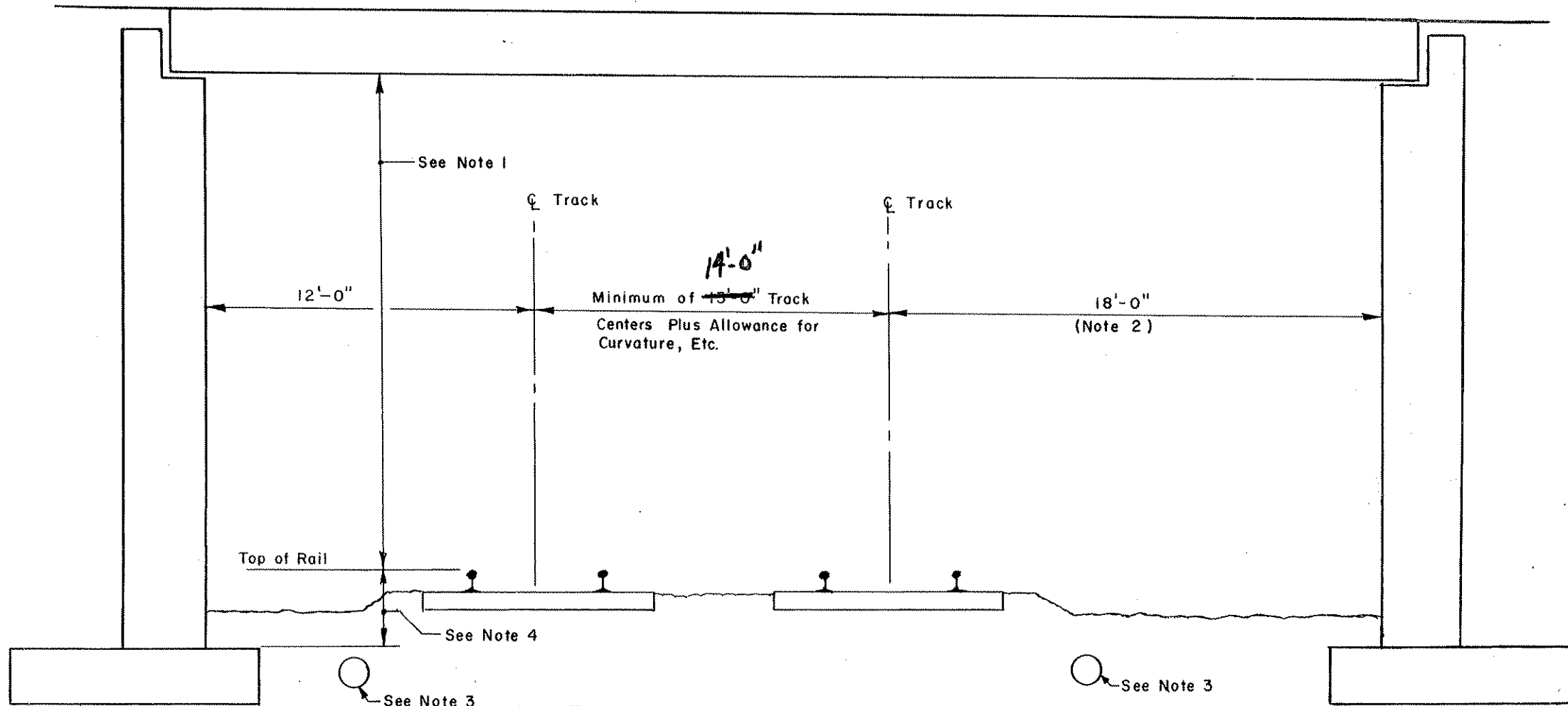

NOTES

1. See Drawing No. 1016 for Vertical Clearances by Route Segment.
2. Provide 18'-0" of Side Clearance on Side Designated for Access/Maintenance Roadway.
3. Provide Storm Drains Sized to have a Flow Capacity Equal To Adjacent R.O.W. Ditches, 12" Dia. Min.
4. Wherever Bridge is Built with Less Than 22'-6" Vertical Clearance, Design Footings to Allow Future Undercutting and Lowering Track To Provide 22'-6".

	MASSACHUSETTS BAY TRANSPORTATION AUTHORITY	RAILROAD OPERATIONS	DWG. NO. 1015
			Oct. 28, 1992 <small>ISSUE DATE</small>
John D. Ray <small>ENGINEERING OFFICER</small>		 <small>CHIEF ENGINEERING OFFICER</small>	

**CLEARANCES FOR
NEW OVERHEAD BRIDGES**

MINIMUM ACCEPTABLE VERTICAL CLEARANCES FOR NEW OVERHEAD STRUCTURES

NORTHSIDE			SOUTHSIDE		
LINE	SEGMENT/LOCATION	Min. Clear	LINE	SEGMENT/LOCATION	Min. Clear
East Route Main Line	Boston to Everett Junction	20'-8"	Framingham (B&A) Main Line	Riverside to Framingham	22'-6"
East Route Main Line	Everett Junction to Newburyport	18'-0"	Shore Line (N. E. Corridor)	Boston to Rhode Island State Line	19'-6"
Saugus Branch	Everett Junction to Lynn	20'-0"	Needham Branch	Forest Hills to Newton Upper Falls	18'-0"
Gloucester Branch	Beverly Junction to Rockport	18'-0"	Dedham Secondary	Readville to Dedham	18'-0"
Danvers Branch	Salem to Danvers	18'-0"	Stoughton Branch	Canton Jct. to Whittendon Jct.	18'-0"
West Route Main Line	Boston to Wilmington Junction	18'-0"	Millis Secondary	Needham, Junction to Millis	18'-0"
West Route Main Line	Wilmington Junction to State Line	22'-6"	Franklin Branch	Readville to Franklin	19'-6"
Newburyport Branch	Wakefield to Topsfield	18'-0"	East Junction Secondary	Attleboro to Seekonk	18'-0"
South Middleton Branch	West Peabody to South Middleton	18'-0"	Old Colony Main Line	Boston to Braintree	18'-0"
M & L Branch	Lawrence to State Line	18'-0"	Middleboro Secondary	Braintree to Middleboro	20'-8"
New Hampshire Main Line	Boston to Lowell (Bleachery)	20'-8"	Plymouth Secondary	Braintree to Plymouth	18'-0"
New Hampshire Main Line	Lowell (Bleachery) to State Line	22'-6"	Greenbush Secondary	Braintree to Greenbush	18'-0"
Woburn Branch	Winchester to Woburn	18'-0"			
Stoneham Branch	Montvale to Stoneham	18'-0"			
Wildcat	Wilmington to Wilmington Junction	20'-8"			
Billerica Secondary	North Billerica to Bennett Hall	18'-0"			
Fitchburg Main Line	Boston to Willows (Ayer)	20'-8"			
Fitchburg Main Line	Willows (Ayer) to Fitchburg	22'-6"			
Central Mass. Branch	Clematis Brook to Berlin	18'-0"			
Marlboro Secondary	Hudson to Marlboro	18'-0"			
Greenville Branch	Ayer to N.H. State Line	18'-0"			

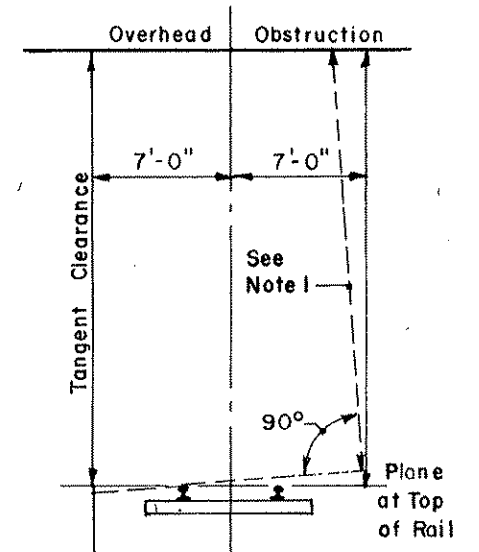

Where there are vertical curves, calculate and compensate for mid ordinate of an 85'-0" long car.

NOTES

1. Superelevated track is to have clearance measurements taken perpendicular to plane of the superelevation as shown in dashed lines.
2. Vertical clearances shall be measured from the lowest projection (rivet, bolt, pipe, etc.) within 7ft. from centerline of track on each side, as shown.
3. Clearances shown are minimums and require MBTA and Mass. DPU approvals under 22'-6".

	MASSACHUSETTS BAY TRANSPORTATION AUTHORITY	RAILROAD OPERATIONS	DWG. NO. 1016 Oct. 28, 1992 ISSUE DATE	(1) ISSUE NO.
	MINIMUM VERTICAL CLEARANCES BY ROUTE SEGMENT			
<i>John D. Ray</i> ENGINEERING OFFICER		<i>WA [Signature]</i> CHIEF ENGINEERING OFFICER		

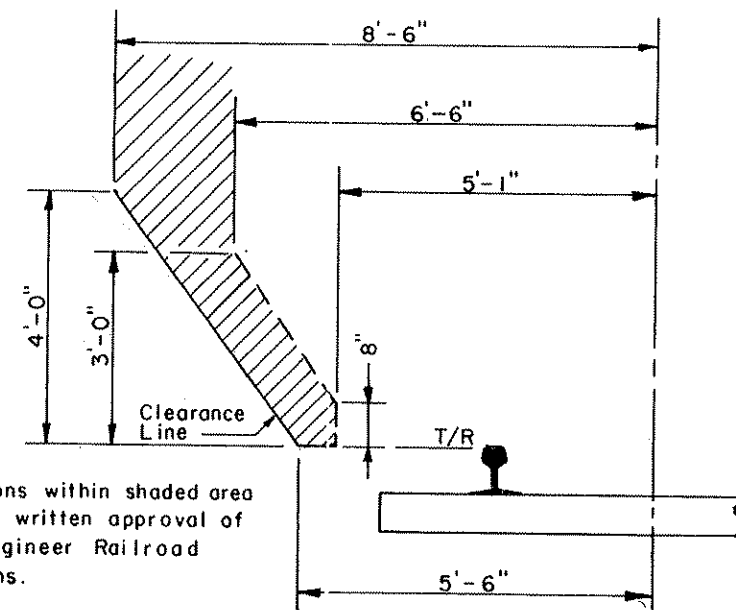
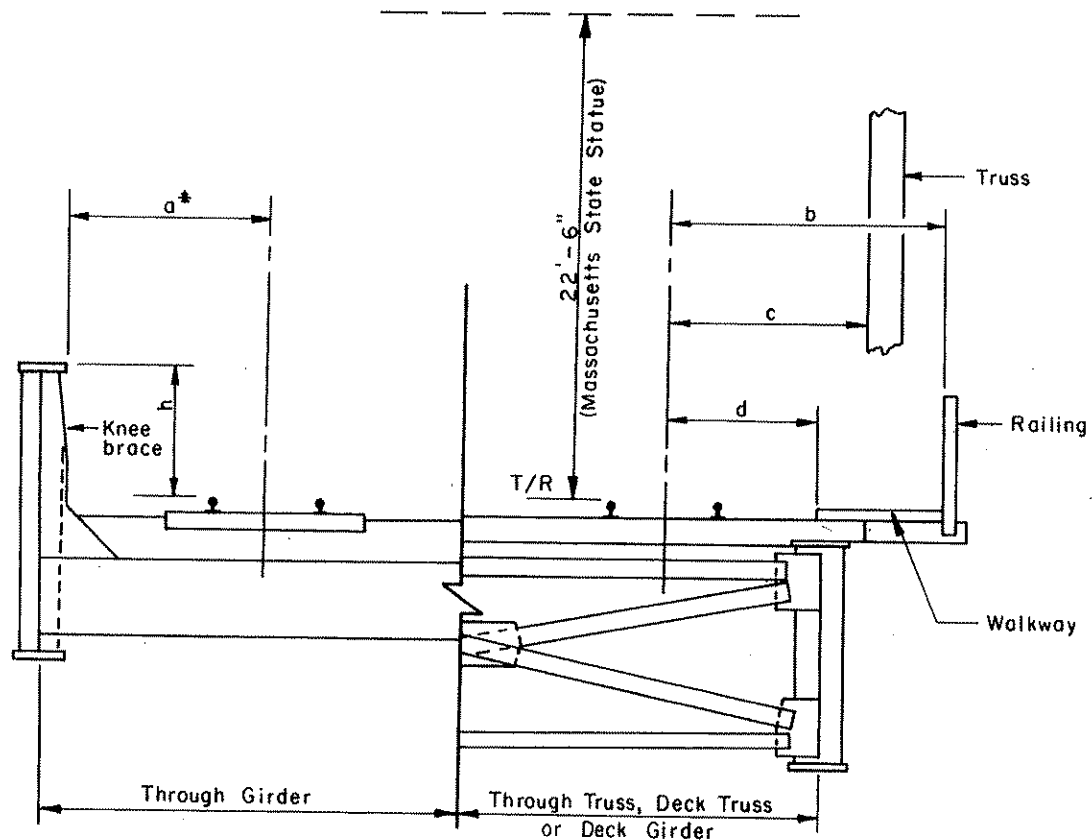

Obstructions within shaded area only with written approval of Chief Engineer Railroad Operations.

DETAIL AT THROUGH PLATE GIRDER

DIMENSION	DESCRIPTION	VALUE
a	Standard side clearance	8'-6" *
b	Clearance to walkway railing	8'-6"
c	Standard side clearance	8'-6"
d	Standard clearance to walkway edge	4'-6"

(For Tangent Track)
 * If dimension 'h' is 4'-0" or less, then dimension 'a' may be reduced as shown above with the following conditions:

- Bridge is not within yard limits.
- Sign "Will not Clear Man on Side of Car" is posted on both ends of the structure.
- On new bridges, a safety walk outside the girder is provided.

open deck bridge (use 5'-1" on ballasted deck provided that walkway is not more than 8" above top of near rail)

For additional clearance for curvature, see Plan 1018.

STANDARD TANGENT TRACK BRIDGE SIDE CLEARANCES
 (For through girder & truss, deck truss & girder)

	MASSACHUSETTS BAY TRANSPORTATION AUTHORITY	RAILROAD OPERATIONS	DWG. NO. 1017
			Oct. 28, 1992 <small>ISSUE DATE</small>
		ISSUE NO. 1	
STANDARD CLEARANCES TANGENT TRACK BRIDGES			
 ENGINEERING OFFICER		 CHIEF ENGINEERING OFFICER	

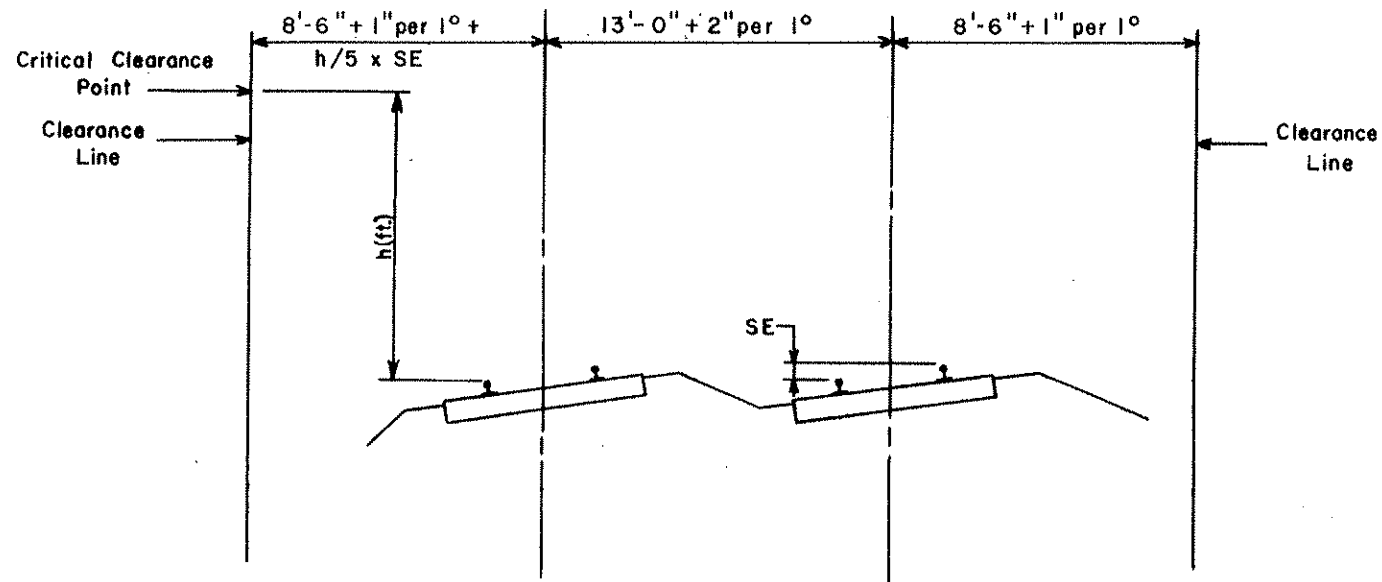

- Standard Side Clearance-Tangent Track ----- 8'-6"
- Track centers between :
 - Mainline Tracks or Yard Tracks ----- 13'-0"
 - Mainline or Passing Track and Ladder Track ---- 17'-0"
- Increased side clearance for curvature ----- 1" per 1° *
- Increased track centers for curvature ----- 2" per 1°
- Increased side clearance for superelevation ----- h/5 x SE
- Where SE is Superelevation in Inches
- h is Height to Obstruction in Feet

* For Clearance Adjustments at Passenger Platforms, see Dwg. No. 1019.

NOTE: Where possible, an 18'-0" side clearance will be provided from the center line of one track for a maintenance roadway.

STANDARD TRACK CENTERS & SIDE CLEARANCE - CURVED TRACK

	MASSACHUSETTS BAY TRANSPORTATION AUTHORITY	RAILROAD OPERATIONS	DWG. NO. 1018
			Oct. 28, 1992 2 <small>ISSUE DATE ISSUE NO.</small>
STANDARD TRACK CENTERS & SIDE CLEARANCE INCREASES FOR CURVED TRACK			
<i>John D. Casey</i> <small>ENGINEERING OFFICER</small>		<i>W. A. ...</i> <small>CHIEF ENGINEERING OFFICER</small>	

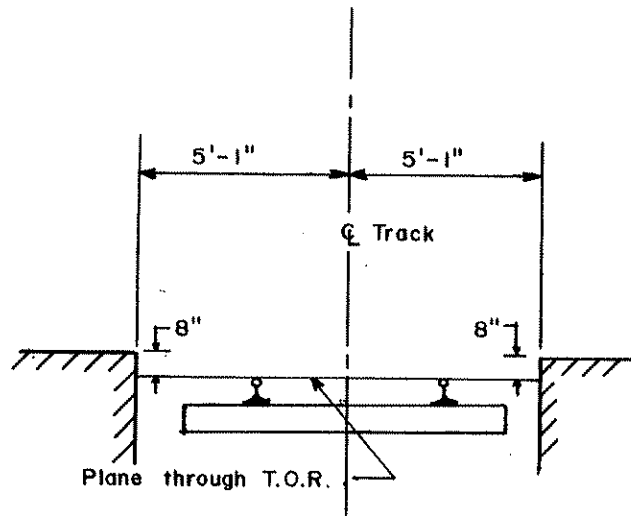

LOW PLATFORM

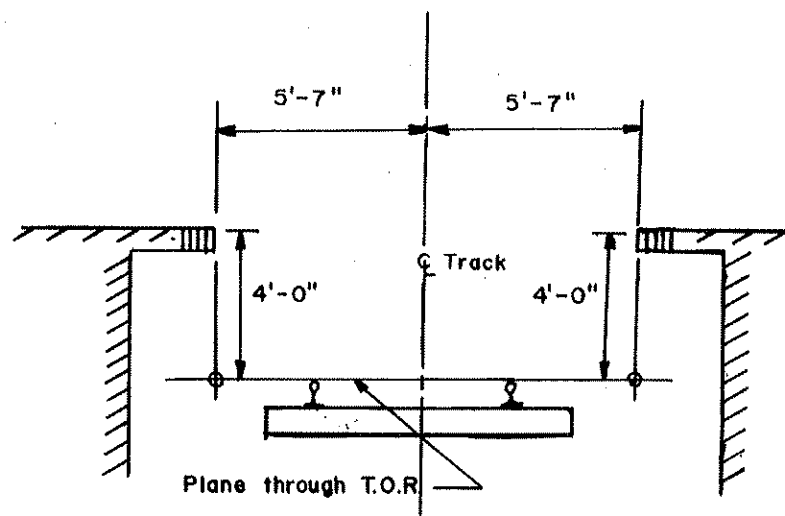

HIGH PLATFORM

TANGENT TRACK

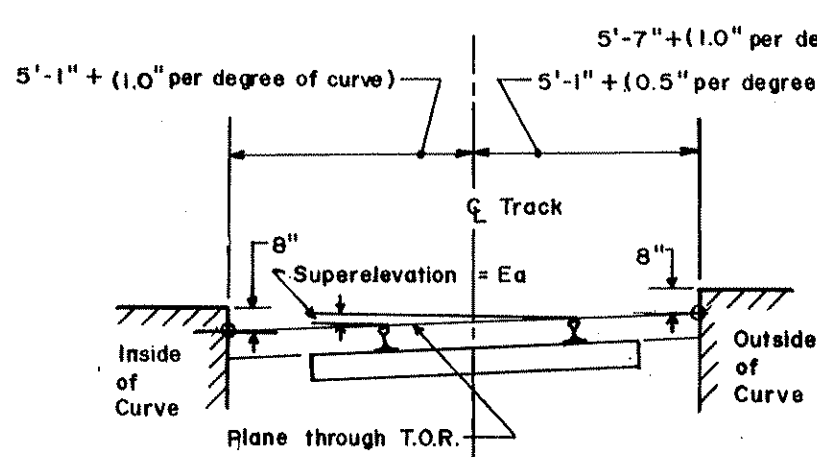

LOW PLATFORM

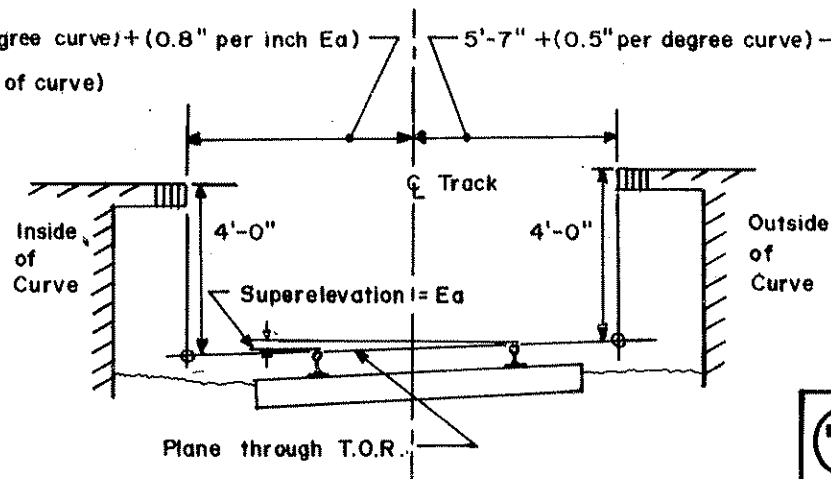

HIGH PLATFORM



CURVED TRACK

NOTES:

1. Where curvature is in excess of 2°-00' and/or superelevation is over 1", horizontal clearance to be reviewed by Chief Engineer Railroad Operations.
2. On certain through freight routes, additional side clearance must be provided for by the use of special fold-up platform edges made of material which will shatter or fold back if accidentally struck in a down position.

T	MASSACHUSETTS BAY TRANSPORTATION AUTHORITY	RAILROAD OPERATIONS	DWG. NO. 1019
		Oct. 28, 1992	ISSUE DATE

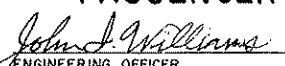
**CLEARANCE AT
PASSENGER PLATFORMS**

 ENGINEERING OFFICER
  CHIEF ENGINEERING OFFICER

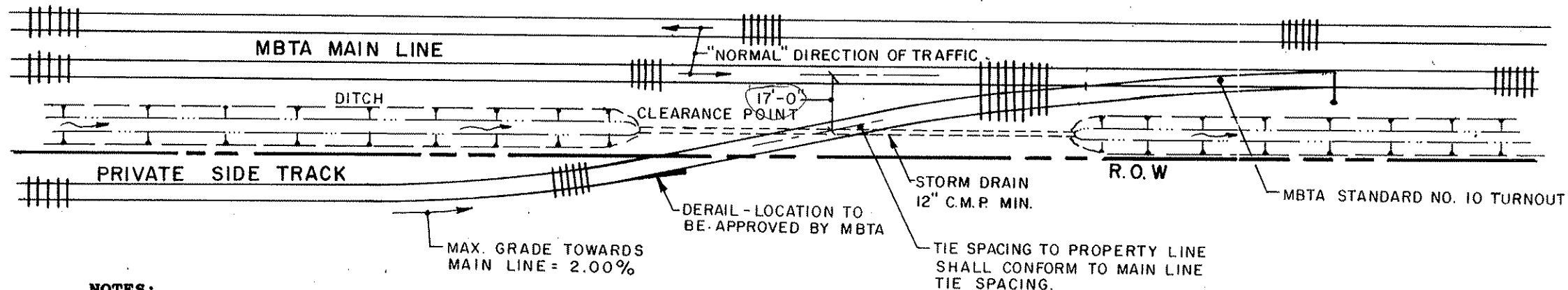

NOTES:

1. Turnout (T.O.) shall be 132 RE, welded, resiliently fastened per MBTA current standard with Hot Mixed Asphalt to be installed under all main line T.O.'s as per plan 1030.
2. No relay rail will be permitted on MBTA property, except with the express written permission of the MBTA and under no circumstances shall the rail differ from the main line rail in weight or section.
3. All T.O.'s shall be trailing point (as depicted) with respect to normal traffic direction unless otherwise permitted with the express written authorization from the MBTA.
4. MBTA forces (or their designee) shall perform all T.O. installation and trackwork on MBTA property to the property line.
5. In territory with concrete ties, those serviced by the sidetrack shall be responsible for the costs of removal of the concrete ties and additional Transition ties to maintain track integrity.
6. Sidetracks which slope down toward the main line shall not exceed a 2% grade (2ft. vertical per 100ft. linear).
7. Any sidetrack sloping toward the main line shall be equipped with a Split Switch Derail with installation and maintenance of the Derail the responsibility of those serviced by the Sidetrack unless otherwise approved. Location of the Derail subject to MBTA approval.
8. Under no circumstances shall railroad cars or other equipment encroach beyond the clearance point and should clearance point be on MBTA property. No car or equipment shall be allowed to stand between the property line and the clearance point without the express written permission of the MBTA.
9. Unattended derails shall be kept locked at all times in the normal position (Derail "on") if the sidetrack is occupied by railroad cars.
10. Additional structures, such as bollards, may be necessary to protect the main line and the cost of these additional structures shall be borne by those serviced by the sidetrack.

11. The maximum curvature (calculated by chord definition) on sidetracks shall be a degree of curve not exceeding $12^{\circ}30'$ unless otherwise allowed by the designated freight railroad servicing the sidetrack but in no case on MBTA property shall the degree of curve exceed $12^{\circ}30'$.

12. Existing drainage patterns shall be maintained (where necessary) by the installation of a pipe (12" min.) to facilitate drainage flow across Sidetrack area. Pipe shall have a flow capacity equal to the ditch and shall be reviewed by the MBTA on a site specific basis. Pipe shall be designed for railroad loadings (E-80) at expected depth below bottom of tie.

T	MASSACHUSETTS BAY TRANSPORTATION AUTHORITY	RAILROAD OPERATIONS	DWG: NO. 1020
			Oct. 28, 1992 ISSUE DATE
		1 ISSUE NO.	
SIDE TRACK INSTALLATION			
<i>John D. Ray</i> ENGINEERING OFFICER		<i>W. A. H. Gould</i> CHIEF ENGINEERING OFFICER	

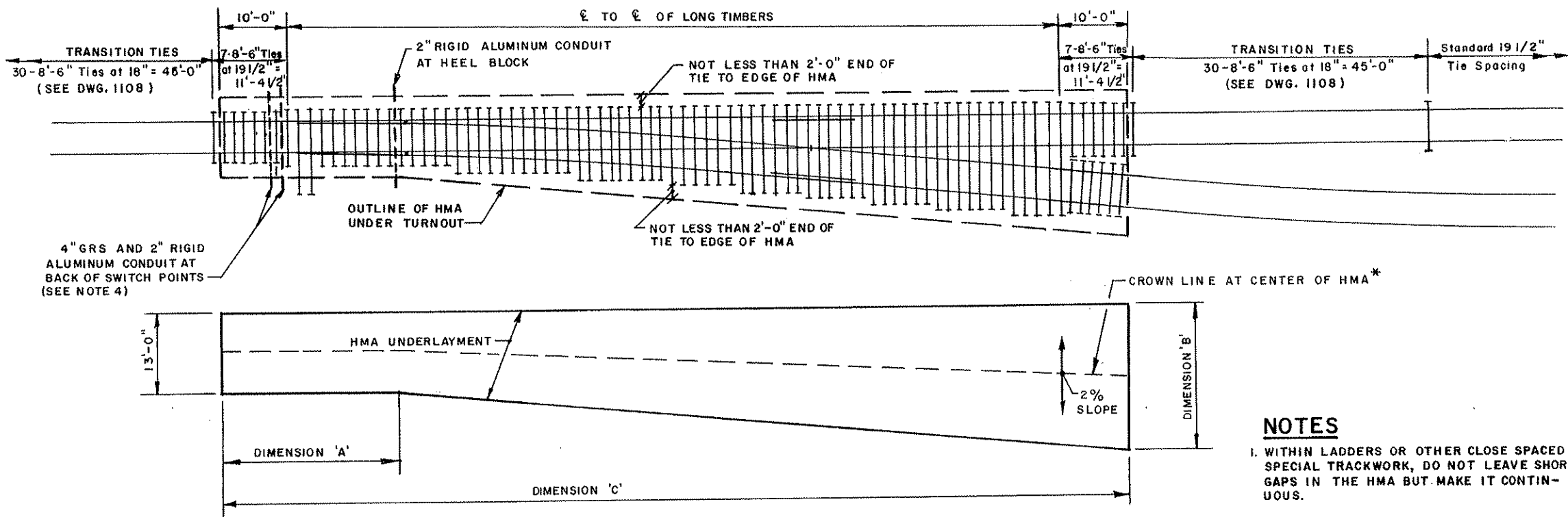

PLAN-TYPICAL TURNOUT INSTALLATION

NOTES

1. WITHIN LADDERS OR OTHER CLOSE SPACED SPECIAL TRACKWORK, DO NOT LEAVE SHORT GAPS IN THE HMA BUT MAKE IT CONTINUOUS.
2. PROVIDE TRANSITION TIES IN MAINLINE TRACK ONLY. FOR ADDITIONAL DETAILS, SEE STANDARD DRAWING NO. 1108.
3. TONS OF HMA CALCULATED AS 0.059 TONS/S.Y./INCH THICKNESS OF HMA.
4. PROVIDE INDICATED CONDUITS AT ALL POWER TURNOUTS AND WHERE ELECTRIC SWITCH HEATERS ARE TO BE INSTALLED. SEE DRAWING NO. 3040 ALSO.

TURNOUT SIZE	DIM. A	DIM. B	DIM. C	TONS OF HMA
NO. 8 TURNOUT	24'-2"	22'-7"	117'-6"	65
NO. 10 TURNOUT	24'-4"	22'-5"	136'-0"	76
NO. 15 TURNOUT	27'-8"	22'-3"	190'-4"	109
NO. 20 TURNOUT	42'-3"	22'-2"	252'-0"	139

(NOTE 3)

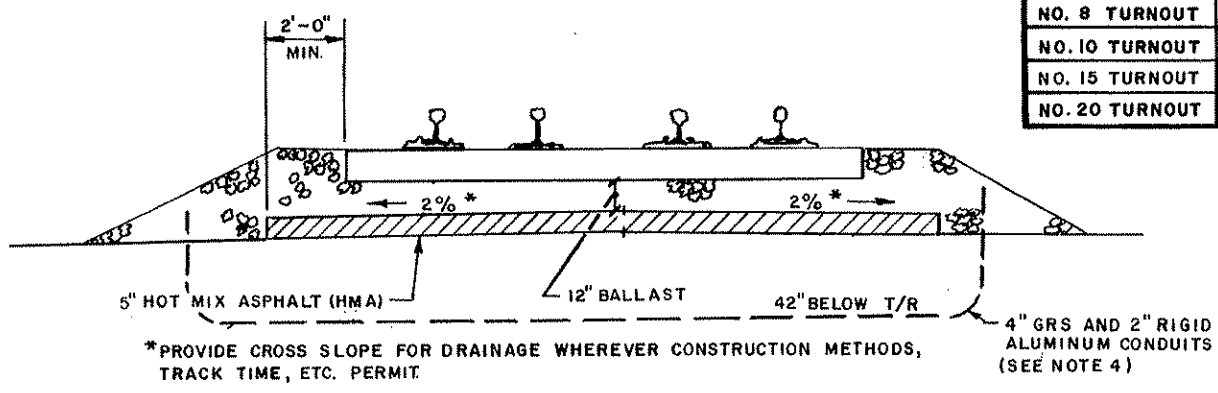

TYPICAL SECTION

* PROVIDE CROSS SLOPE FOR DRAINAGE WHEREVER CONSTRUCTION METHODS, TRACK TIME, ETC. PERMIT.

4" GRS AND 2" RIGID ALUMINUM CONDUITS. (SEE NOTE 4)

T	MASSACHUSETTS BAY TRANSPORTATION AUTHORITY	RAILROAD OPERATIONS	DWG. NO. 1030
			ISSUE DATE Apr. 29, 1996 ISSUE NO. 3
ASPHALT UNDERLAYMENT AT TURNOUTS			
 SECTION CHIEF			

BUNDLE TIES IN GROUPS OF 24 PIECES
 CONSISTING OF FOUR ROWS OF SIX
 TIES ON EDGE.

TWO - 2" x 0.05" HEAVY DUTY STEEL STRAPS
 WITH TWO SEALS PER BAND

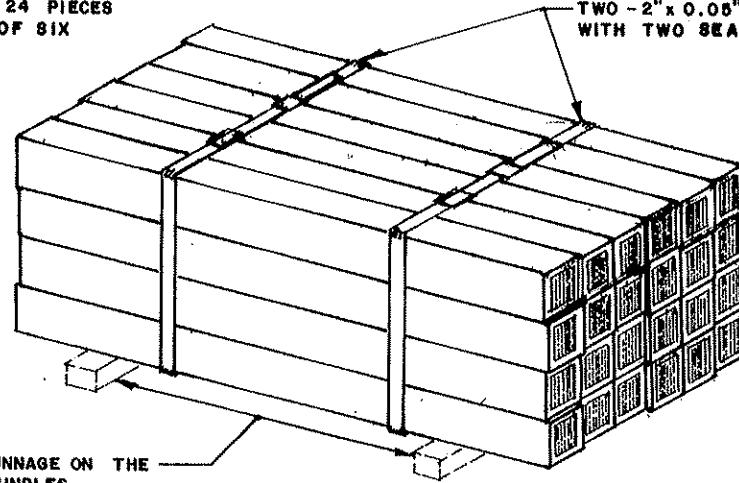

4" x 4" WOOD DUNNAGE ON THE
 BOTTOM OF ALL BUNDLES

NOTES:

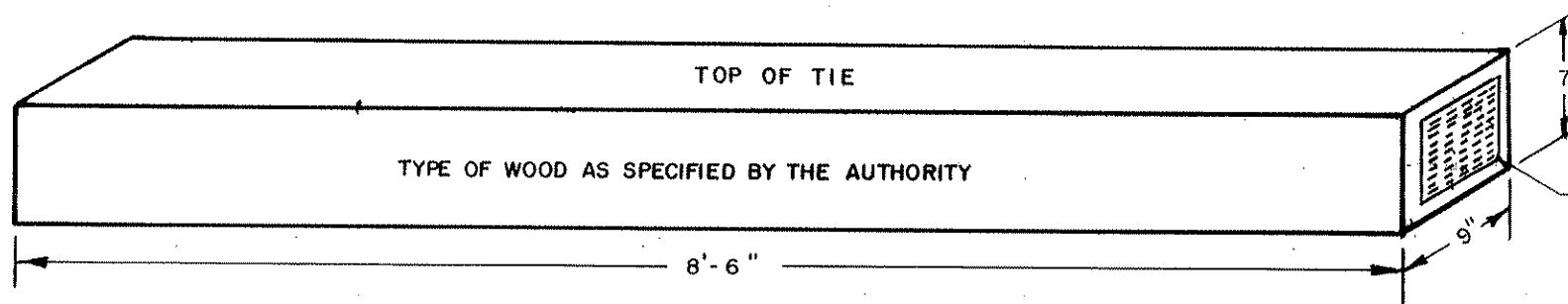

1. ALL TIES SHALL CONFORM TO MBTA STANDARD
 MATERIAL SPECIFICATIONS FOR CROSS-TIES-
 TREATED.

BUNDLES FOR SHIPMENT



ANTI-SPLITTING END PLATE (BOTH ENDS)
 SEE PLAN NO. 1106 - APPLY PRIOR TO SEASONING

STANDARD TIE

 MASSACHUSETTS BAY TRANSPORTATION AUTHORITY	RAILROAD OPERATIONS	DWG. NO. 1100	 ISSUE NO.
		Oct. 28, 1992	
STANDARD TIMBER TIE			
<i>John D. Ray</i> ENGINEERING OFFICER		<i>W. A. ...</i> CHIEF ENGINEERING OFFICER	

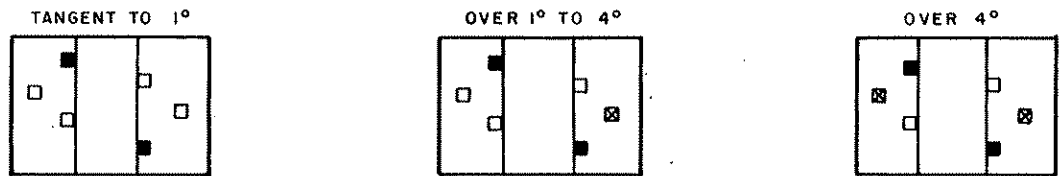

STANDARD TIE PLATE (B-6 PUNCHING) WITH CUT SPIKES

■ INDICATES RAIL HOLDING SPIKES ⊠ INDICATES ADDITIONAL CUT SPIKES

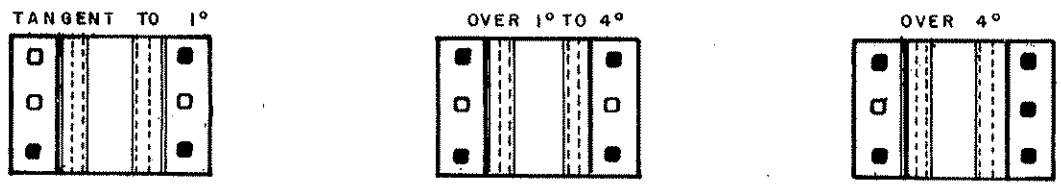

STANDARD RESILIENTLY FASTENED TIE PLATE

■ INDICATES USE OF LOCK SPIKE IN SPIKE HOLE.
 PREBORE HOLES FOR LOCK SPIKES, 9/16" DIA. X 6" DEEP.
 DO NOT BORE HOLES ALL THE WAY THROUGH THE TIE.

NOTES:

1. LEFT SIDE OF ALL DEPICTED PLATES TO BE CONSIDERED THE FIELD SIDE WITH THE GAGE SIDE ON THE RIGHT.
2. SEE SHEET 1216 FOR LOCK SPIKE DETAIL.

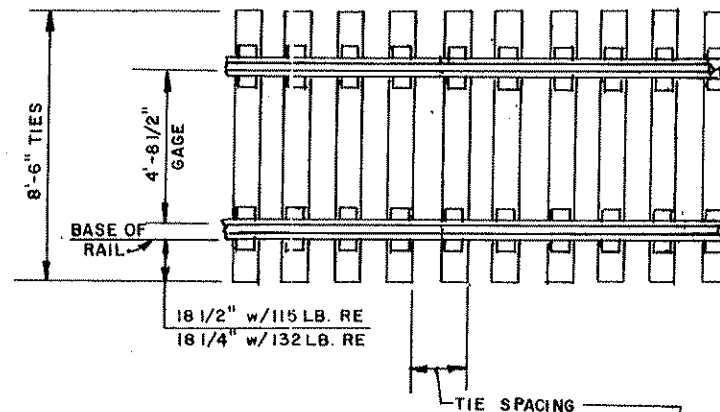

TIMBER TIES	
STANDARD MAIN LINE TRACK-----	19 1/2"
WITHIN GRADE CROSSINGS*-----	18"
SECONDARY & YARD TRACK-----	22"
CONCRETE TIES	
STANDARD MAIN LINE TRACK-----	24"

* Ties within full depth rubber crossings shall be 9'-0" long. Temporary crossings may have 19 1/2" spacing. Use 18" spacing within transition areas as shown on drawing no. 1108.

STANDARD TIE SPACING

	MASSACHUSETTS BAY TRANSPORTATION AUTHORITY	RAILROAD OPERATIONS	DWG. NO. 1104
			Jan. 5, 1998 ²
		ISSUE DATE	ISSUE NO.

TIE SPACING AND SPIKING PATTERNS

John D. Ray
 SECTION CHIEF

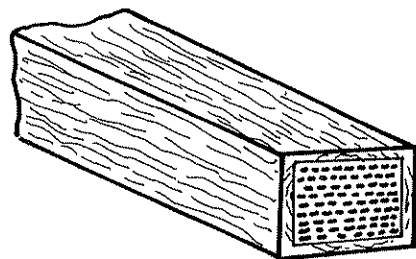

TYPICAL TIE END VIEW

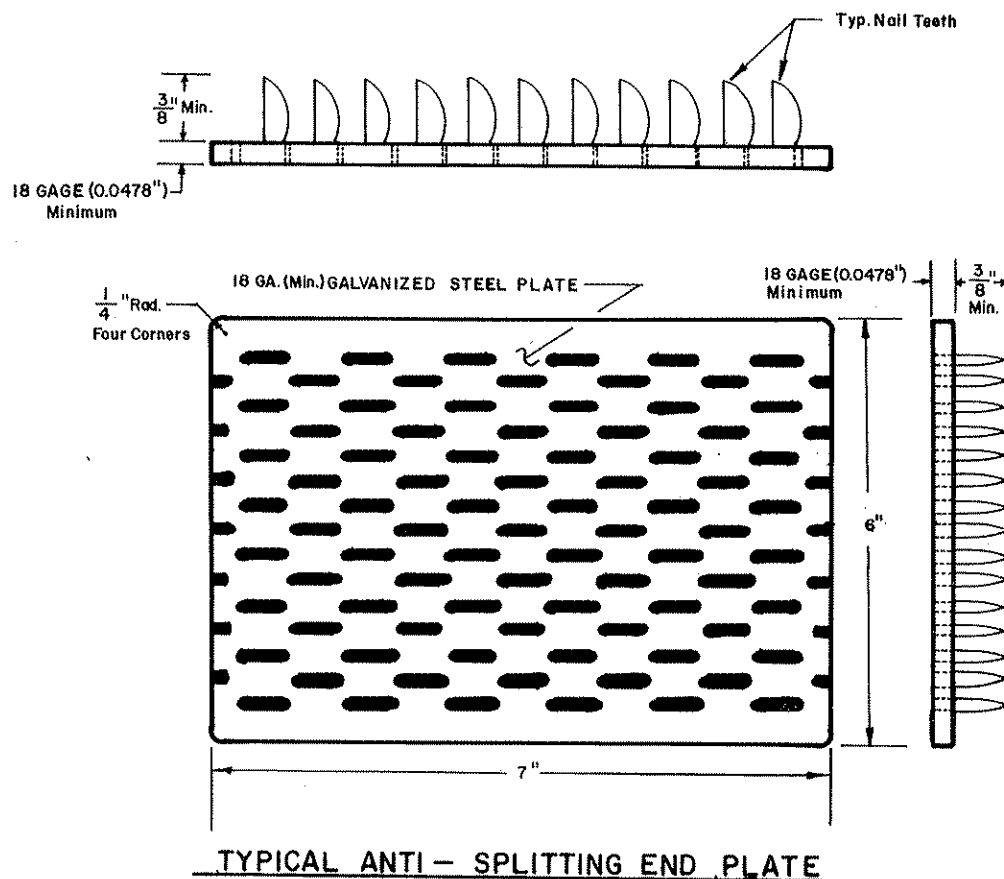

TYPICAL ANTI-SPLITTING END PLATE

NOTES:

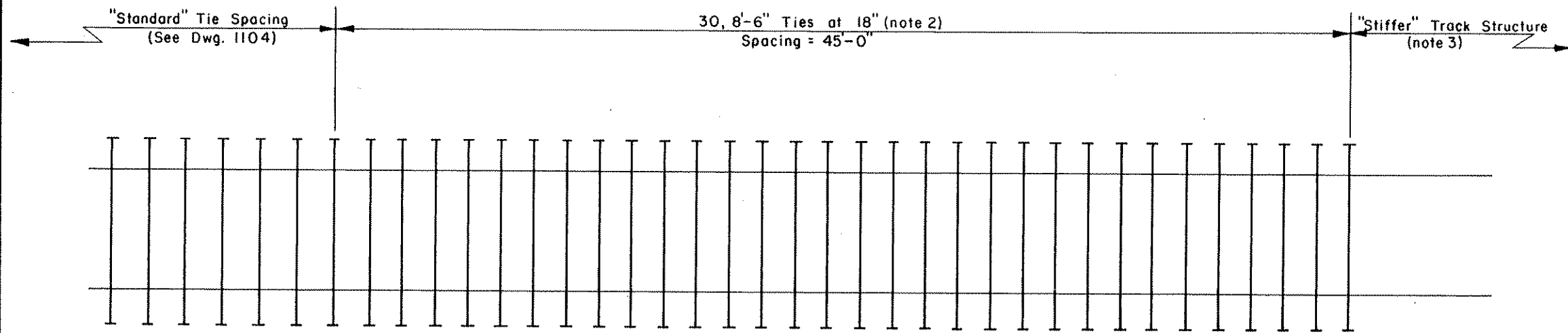

1. The Anti-Splitting End Plate (ASEP) shall be manufactured from a minimum 18 Ga. (0.0478") galvanized steel plate, hot dipped.
2. The ASEP shall have nail teeth not less than 3/8" in length and of sufficient sharpness to fully penetrate hardwood timbers used for cross ties.
3. The ASEP shall be machine applied to the ends of a tie with uniform pressure and minimum teeth bending and shall be applied so that the nail teeth side of the plate is flush with end surface of the tie.
4. The ASEP is to be applied to new ties prior to seasoning.
5. The center of the ASEP is to be applied not more than 1/2" off the horizontal and vertical centerline intersections of the tie end.
6. The ASEP shall be fabricated in such a way that the teeth twist vertically to allow a better grip in the tie.
7. Mark and install plates to indicate location of Heartwood (KERF Marks).

	MASSACHUSETTS BAY TRANSPORTATION AUTHORITY	RAILROAD OPERATIONS	DWG. NO. 1106 Oct. 28, 1992 <small>ISSUE DATE</small>	(2) <small>ISSUE NO.</small>
	ANTI-SPLITTING END PLATE FOR CROSSTIES & SWITCH TIMBER			
<i>John D. Ray</i> <small>ENGINEERING OFFICER</small>		<i>W. H. ...</i> <small>CHIEF ENGINEERING OFFICER</small>		



NOTES :

1. Use Transition Ties whenever there is a significant change in track Modulus (Stiffness).
2. Tie spacing dimension is shown for speeds up to 60 mph. For speeds greater than 60 mph, increase as follows:
 - 70 mph - 35 Ties at 18" = 52'-6"
 - 80 mph - 40 Ties at 18" = 60'-0"
3. "Stiffer" Track Structure consists of any of the following:
 - a. Concrete Ties
 - b. Bridge or Approach Slab
 - c. Hot Mix Asphalt Underlayment (Grade Crossing or Turnout)
 - d. Direct Fixation Track Construction

 MASSACHUSETTS BAY TRANSPORTATION AUTHORITY	RAILROAD OPERATIONS	DWG. No. 1108
		Oct. 28, 1992 <small>ISSUE DATE</small>
<h2 style="margin: 0;">TRANSITION TIES</h2>		
 <small>ENGINEERING OFFICER</small>	 <small>CHIEF ENGINEERING OFFICER</small>	

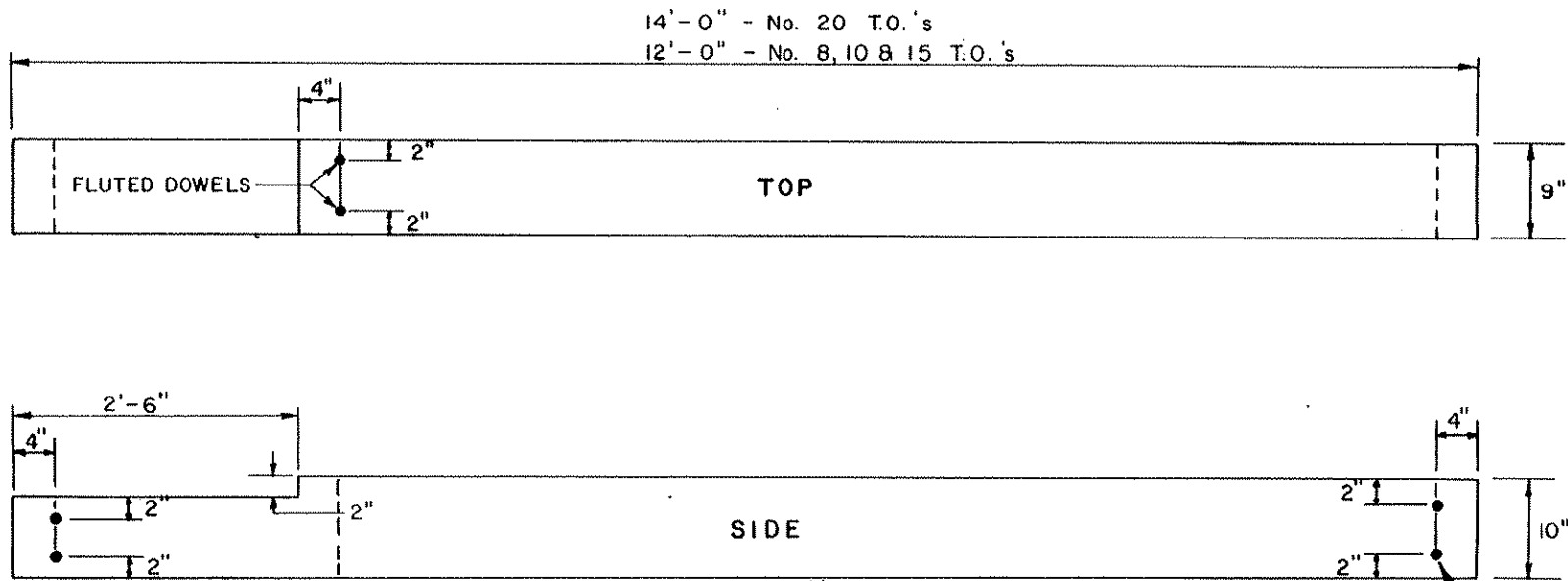

**POWER SWITCH TIMBER FRAMING
(TWO TIMBERS PER MACHINE)**

FLUTED DOWELS
TYP. BOTH ENDS

NOTES:

1. DETAILS ON THIS DRAWING APPLY ONLY TO TURNOUTS TO BE OPERATED BY A SWITCH MACHINE.
2. 14'-0" HEADBLOCKS REQUIRED ON NO. 20 TURNOUTS TO ACCOMMODATE HELPER MECHANISM.

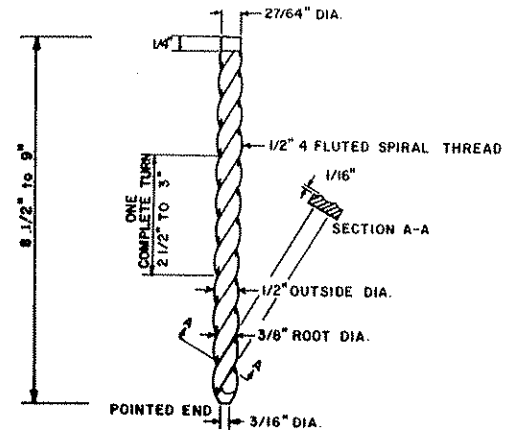

**FLUTED STEEL TIE DOWELS
(6 per Headblock)**

ANTI-SPLIT DOWEL NOTES

1. USE OF LUBRICANTS TO ASSIST IN DRIVING DOWEL IS PROHIBITED.
2. LOCATION OF DOWELS SHALL BE AS SHOWN.
3. MINIMUM LENGTH OF HOLES TO ACCEPT DOWELS SHALL BE EQUAL TO THE LENGTH OF DOWEL, AND THE SIZE OF THE DRILLED HOLES MUST NOT EXCEED 3/8 INCH IN DIAMETER.
4. DOWELS MUST BE COMPLETELY DRIVEN.
5. DOWELS ARE TO BE MADE OF COPPER BEARING STEEL A.S.T.M. A107.
6. TOLERANCE ON DIAMETERS OF 1/64" PLUS OR MINUS IS PERMITTED.

	MASSACHUSETTS BAY TRANSPORTATION AUTHORITY	RAILROAD OPERATIONS	DWG. NO. 1110 Apr. 29, 1996 <small>ISSUE DATE</small>	(3) <small>ISSUE NO.</small>
	HEADBLOCK TIE LAYOUT & DAPPING DETAILS			
<i>John D. Ray</i> <small>SECTION CHIEF</small>				

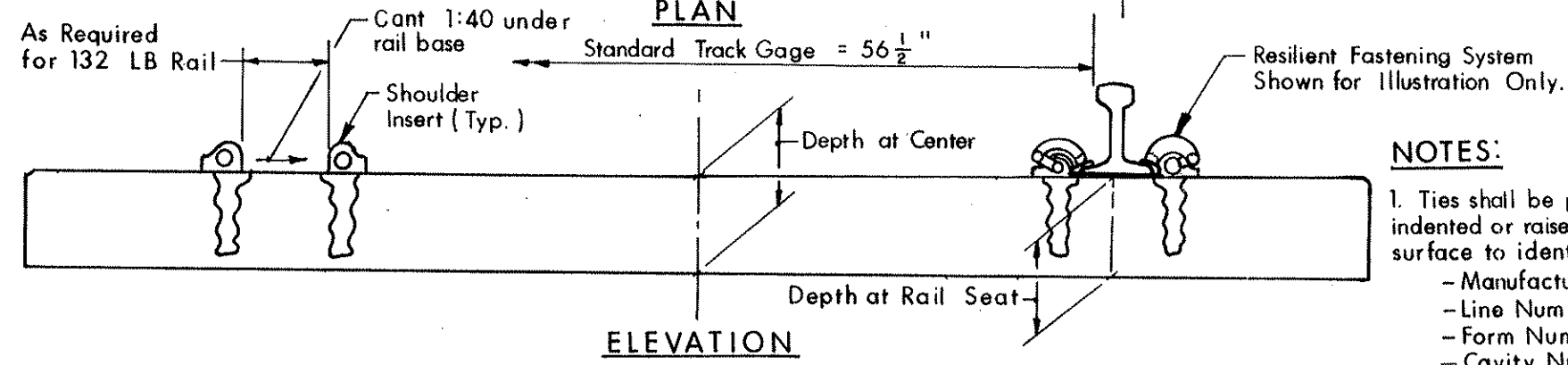
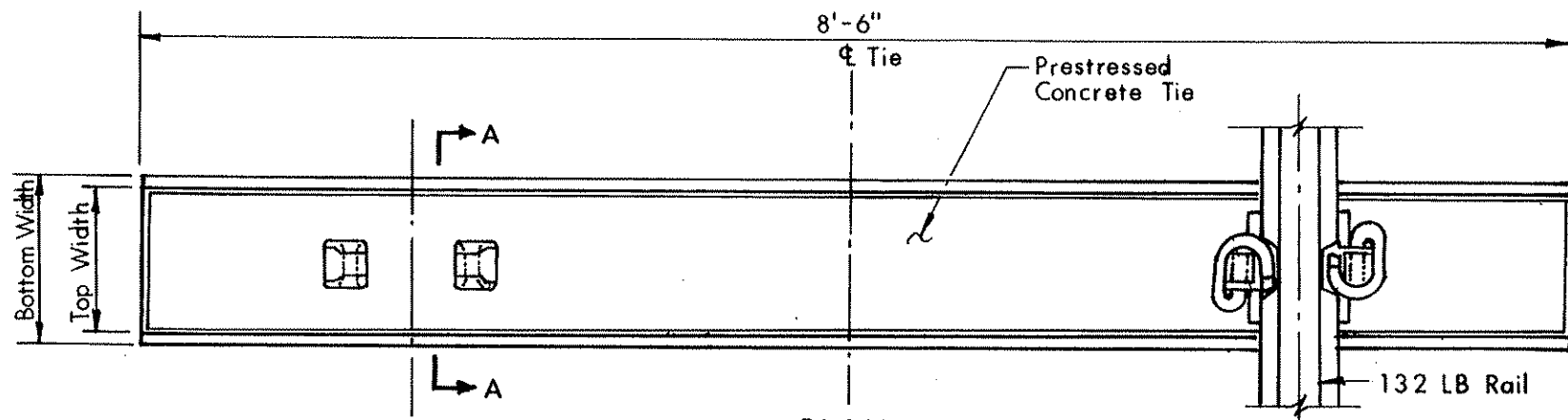

- NOTES:**
- Ties shall be permanently labeled by indented or raised characters on the top surface to identify the following:
 - Manufacturers Identification
 - Line Number
 - Form Number
 - Cavity Number
 - Year of Manufacture
 - Date Code
 - Rail Seat Size
 - Weight of Tie shall not exceed 800 lbs.
 - Conc. Strength (f_c), 7,000 ps.i. min. at 28 days.

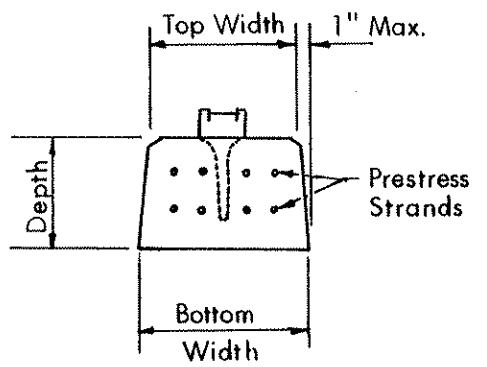

Dimension Description	Minimum	Maximum	Tolerance
Top Width	9"	10"	$\pm 1/8"$
Bottom Width	11"	12"	$\pm 1/8"$
Depth at Center	7"	10"	$+1/4"-1/8"$
Depth at Seat	9 1/2"	10 1/2"	$+1/4"-1/8"$

SECTION A-A

	MASSACHUSETTS BAY TRANSPORTATION AUTHORITY	RAILROAD OPERATIONS	DWG. NO. 1120
			Oct. 28, 1992 <small>ISSUE DATE</small>
		ISSUE NO. 2	
CONCRETE TIE			
<i>John D. Ray</i> ENGINEERING OFFICER		<i>W. A. ...</i> CHIEF ENGINEERING OFFICER	

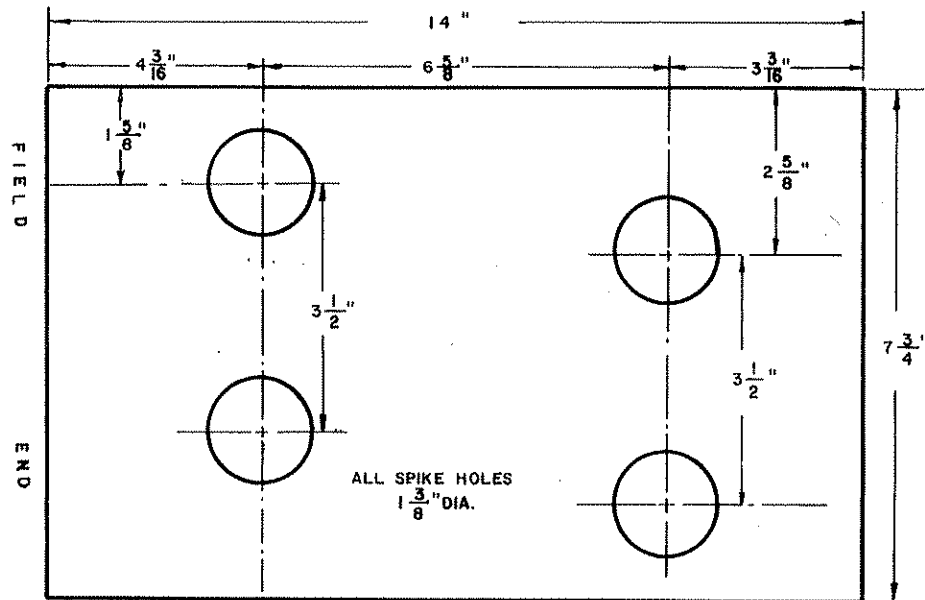

WOOD SHIM FOR TIE PLATES

As Shown Dimensions Will Fit Either 132lb or 115lb Plate (B-6 Punching Only).

NOTES:

1. Shims shall be made of sawed, sound hardwood or marine plywood - prebored as shown.
2. A variation of $\frac{1}{4}$ " more or $\frac{1}{16}$ " less is allowable in length or width with length, width & depth uniform (no wedge shape allowed in any direction).
3. Thickness of shims shall be in $\frac{1}{4}$ " increments from $\frac{1}{2}$ " to $1 \frac{3}{4}$ ".
4. Wood shims not exceeding 1" in thickness may be secured using a standard 6" cut spike but shimming exceeding 1" must be secured using special 8" track spikes.
5. For additional data on use and installation, see drawing 1204 and MW-1 Manual, SECTIONS 213.129 and 213.131.

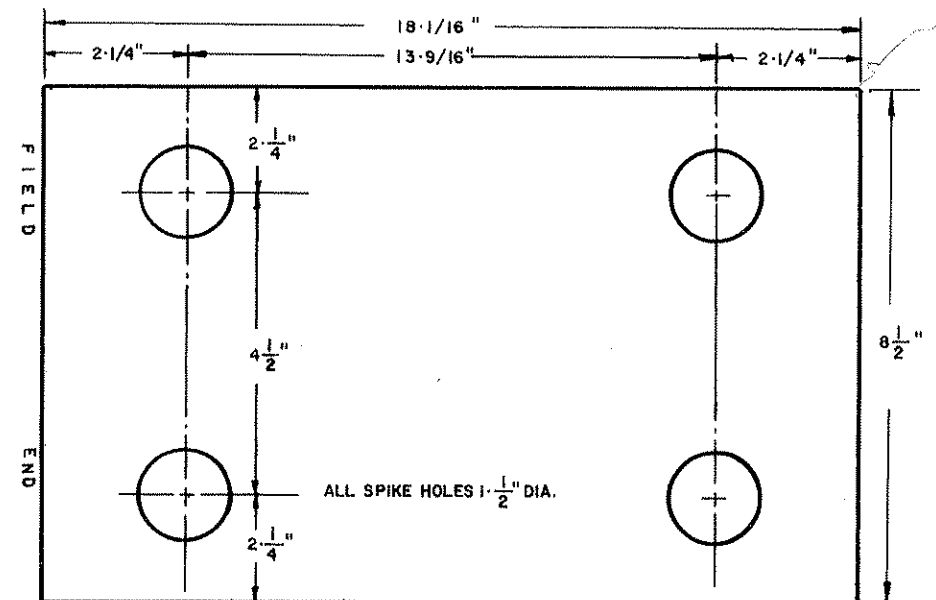

WOOD SHIM FOR RESILIENTLY FASTENED TIE PLATE

As Shown Dimensions Will Fit Either 132lb or 115lb Plate

T	MASSACHUSETTS BAY TRANSPORTATION AUTHORITY	RAILROAD	DWG. NO. 1200
		OPERATIONS	Oct. 28, 1992 ISSUE DATE
		①	ISSUE NO.
WOOD SHIMS FOR TIE PLATES			
<i>John D. Ray</i> ENGINEERING OFFICER		<i>W. A. Wilson</i> CHIEF ENGINEERING OFFICER	

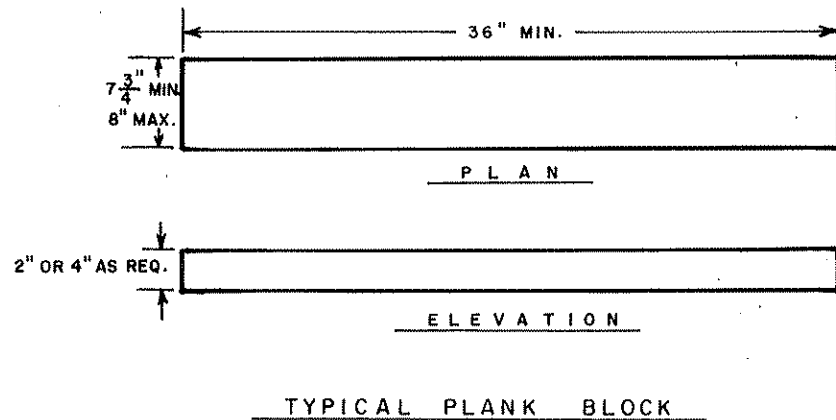

NOTES :

1. Plank blocks are to conform to the dimensional specifications for wood shims (drawing 1200) contained in these standard plans except that plank blocks are to be made from hard wood with additional plate holding spike hole(s) to be bored in the field.
2. Plank blocks are to be applied directly on top of the tie beneath the rail and the tie plate and secured to the tie with spikes as required to penetrate the tie at least 4 inches.
3. When a rail is shimmed 2" or more, a combination of shims and 2" or 4" plank block must be used with the wood shims on top of the plank and secured to it as with 10d or 20d nails depending on thickness of shim.
4. When Plank blocks are used (min. length to be 36"), they are to be applied with one end flush with the end of the tie and spiked to the tie using at least four 8" Boat spikes using 5/8" diameter spike holes bored in the field.
5. If the elevation change permits, full tie length plank blocks shall be used wherever possible.
6. Wood shims not exceeding 1" in thickness may be secured using a standard 6" cut spike but shimming exceeding 1" must be secured using special 8" track spikes.

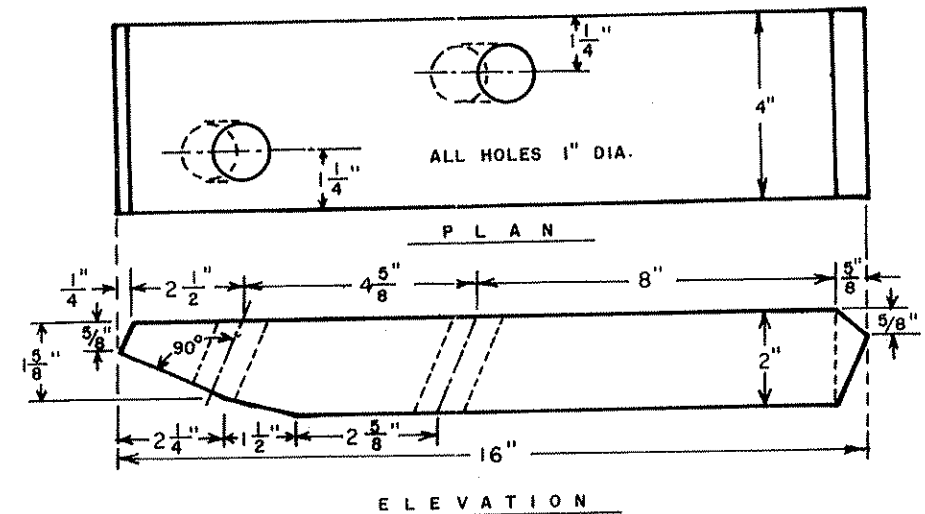

7. When a rail is shimmed more than 1 1/2" it must be securely braced at least every third tie for the full length of the shimming.
8. Braced and/or shimmed track should be checked frequently for alignment, gage, and cross level as well as to assure that the braces and/or shims are tight.
9. It should be stressed that shimming and blocking should be considered a method of last resort in correcting rail elevation mismatch problems when the track subgrade is frozen and cannot be worked.
10. Record of Shim/Block installations must be maintained in the office of Engineer of Track.

 MASSACHUSETTS BAY TRANSPORTATION AUTHORITY	RAILROAD OPERATIONS	DWG. NO. 1204 Oct. 28, 1992 <small>ISSUE DATE</small>	 <small>ISSUE NO.</small>
	<h2 style="margin: 0;">FROST BRACING AND BLOCKING</h2>		
 <small>ENGINEERING OFFICER</small>	 <small>CHIEF ENGINEERING OFFICER</small>		

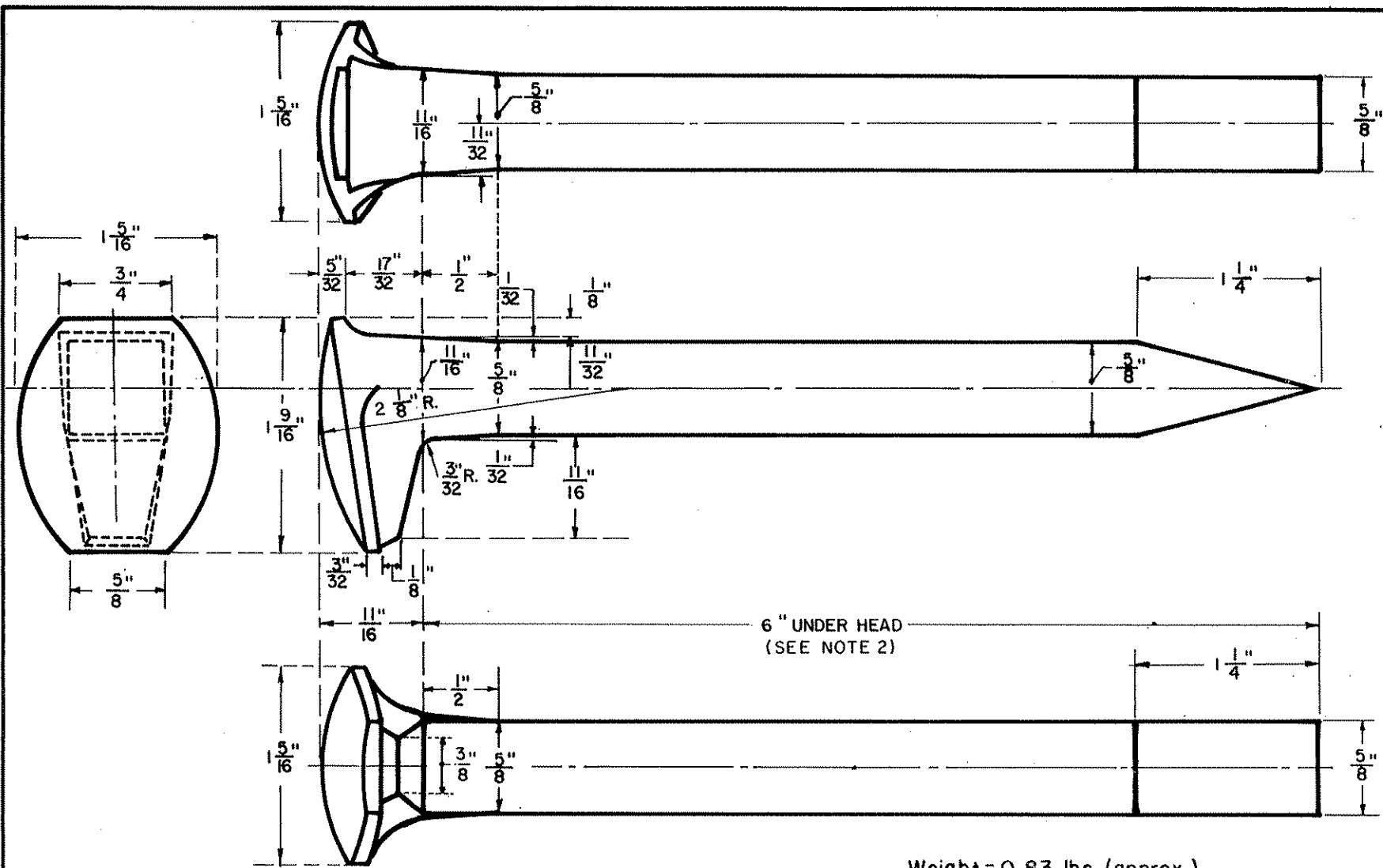

NOTES:

1. See A.R.E.A. Specifications for Soft Steel Track Spikes for Process, Chemical Composition, Tensile Properties, Bending Properties, and other standards.
2. Spikes used for frost shims shall have a length dimension of 8" under the head.
3. Spikes shall be shipped in steel kegs which do not exceed a weight of 200 lbs.

Weight = 0.83 lbs (approx.)
 Approx. 240 Spikes per 200 lb. keg

STANDARD CUT TRACK SPIKE

	MASSACHUSETTS BAY TRANSPORTATION AUTHORITY	RAILROAD OPERATIONS	DWG. NO. 1210
			Oct. 28, 1992 2 <small>ISSUE DATE ISSUE NO.</small>
<p>CUT SPIKE</p> <p><i>John D. Ray</i> <i>W. A. ...</i> <small>ENGINEERING OFFICER CHIEF ENGINEERING OFFICER</small></p>			

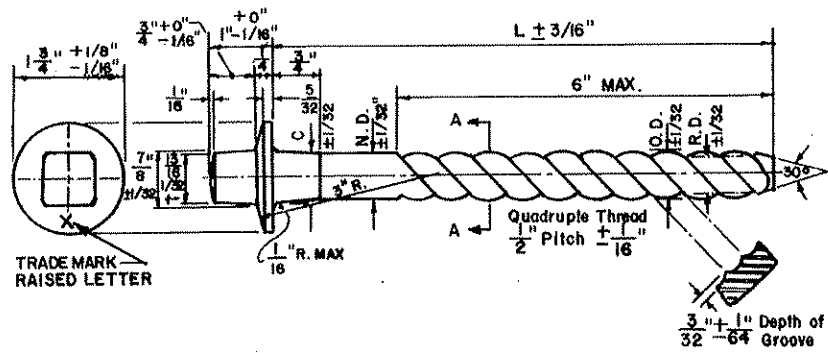

DESCRIPTION	N.D. - NOMINAL DIAMETER		
	5/8"	11/16"	3/4"
O.D. OF THREAD	23/32"	25/32"	27/32"
R.D. ROOT DIAMETER	17/32"	19/32"	21/32"
C - TOP OF CONE NECK	11/16"	25/32"	13/16"

NOTE
* Order By Nominal Diameter
And Length Under Head



A.R.E.A. WASHER-HEAD TIMBER DRIVE SPIKE

Not to Scale

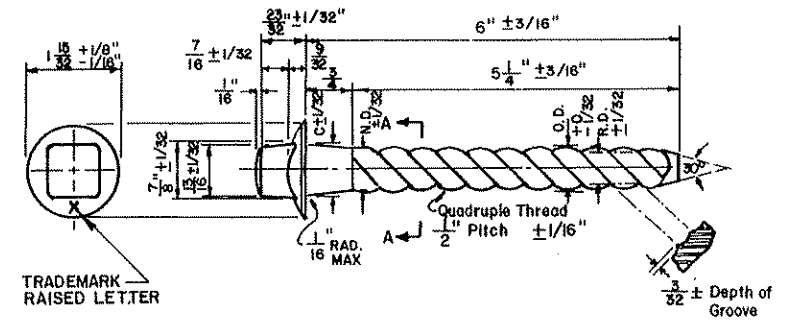

DESCRIPTION	N.D. NOMINAL DIAMETER	
	11/16"	3/4"
O.D. OF THREAD	23/32 MAX.	25/32 MAX.
R.D. - ROOT DIAMETER	17/32"	19/32"
C - TOP OF CONE NECK	25/32"	27/32"

NOTES
Other Lengths Procurable
Order by Nominal Diameter.
Designed to Fit 11/16" and 3/4"
Square and Round Holes



A.R.E.A. CONE-NECK DRIVE SPIKE

Not to Scale

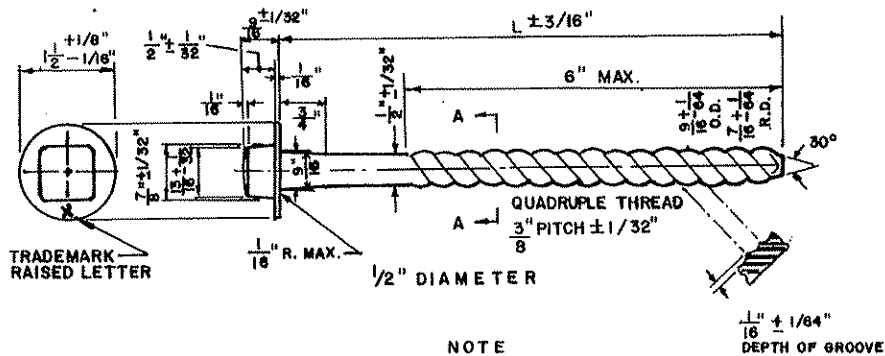

NOTE
Order By Nominal Diameter
And Length Under Head.



A.R.E.A. TIMBER DRIVE SPIKE

Not to Scale

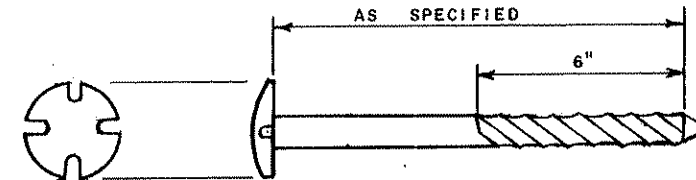

SPIKE DIAMETER	HEAD DIAMETER	HEAD THICKNESS	LENGTH
1/2" Nominal Diameter	2"	19/64"	6", 8", 10" or 12"
5/8" "	2 1/2"	11/32"	8" to 14"
3/4" "	2 1/2"	11/32"	8" to 14"

DOME HEAD DRIVE SPIKE

Not to Scale

NOTE:

ALL DRIVE SPIKES TO CONFORM TO CURRENT
A.R.E.A. SPECIFICATIONS FOR STEEL DRIVE
SPIKES, CHAPTER 5, MISCELLANEOUS PART.

	RAILROAD OPERATIONS	DWG. NO. 1214
		Oct. 28, 1992
	ISSUE DATE	ISSUE NO.

TIMBER DRIVE SPIKES

ENGINEERING OFFICER

CHIEF ENGINEERING OFFICER

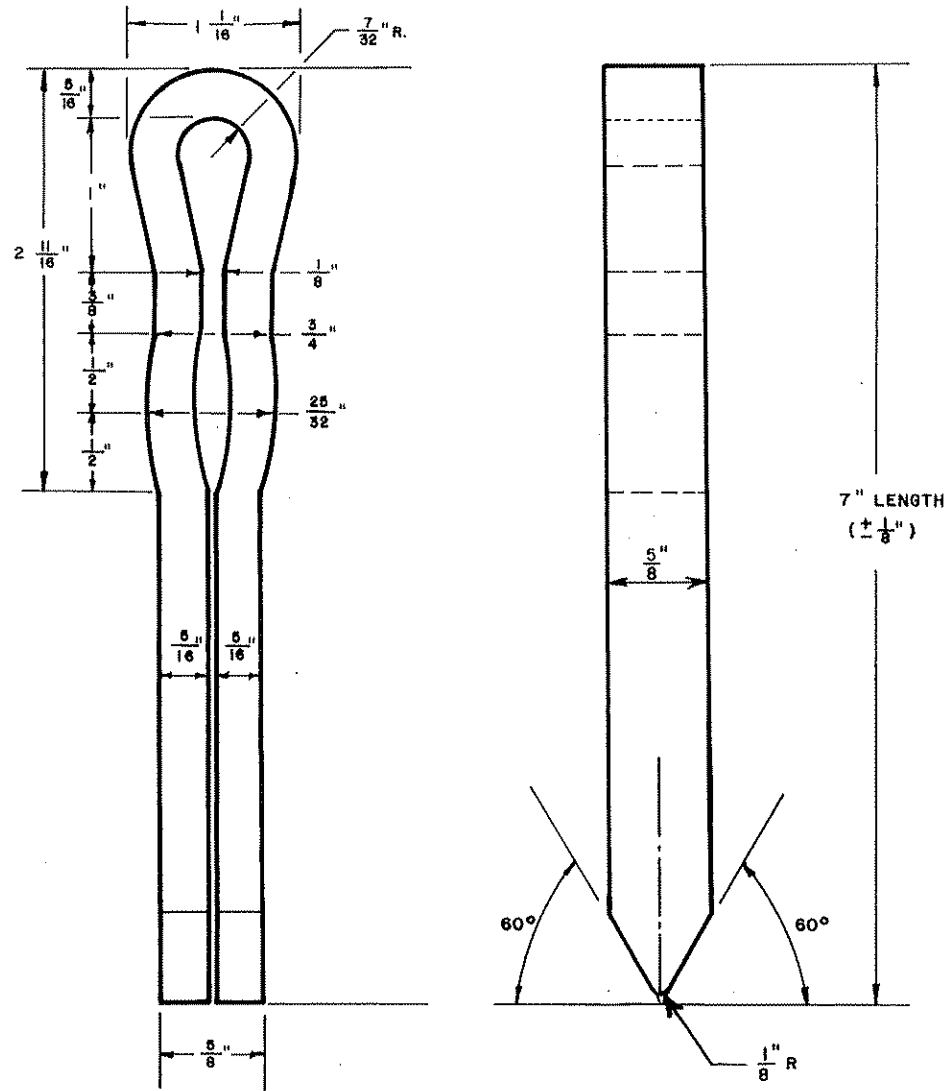

LOCK SPIKE FOR TIE PLATE

NOTE:

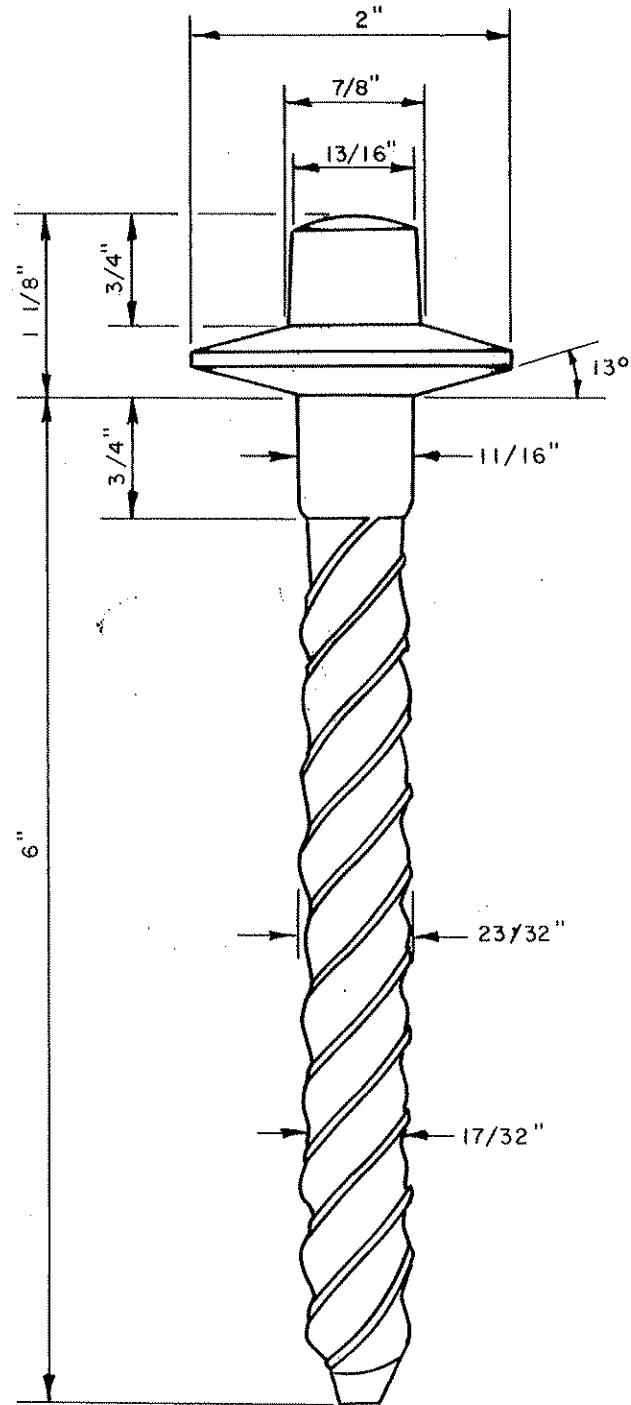

1. Lock Spikes shall be manufactured from $\frac{5}{8}$ " X $\frac{5}{16}$ " alloy spring steel with a minimal tensile strength of 160,000 p.s.i. and elongation of 25 %.
2. When Lock Spikes are driven into an $\frac{11}{16}$ " square spike hole (in free air), the legs shall open $\frac{1}{8}$ " (minimum).
3. For Spiking patterns, see drawing NO. 1104

 MASSACHUSETTS BAY TRANSPORTATION AUTHORITY	RAILROAD OPERATIONS	DWG. NO. 1216
		Oct. 28, 1992 2 <small>ISSUE DATE ISSUE NO.</small>
LOCK SPIKE FOR TIE PLATES		
<i>John D. Ray</i> <small>ENGINEERING OFFICER</small>		<i>W. A. Ronald</i> <small>CHIEF ENGINEERING OFFICER</small>



NOTES:

1. Track Drive Spikes shall be hot forged from medium carbon steel conforming with ASTM A-66.
2. Prebore holes either 7/16" or 1/2" in dia. Drive spike with hammering force only.
3. Track Drive Spikes shall be used instead of cut spikes within turnouts at locations where resilient fasteners cannot be applied. This includes frog guard rails and plates just beyond the heel of switch.

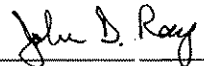
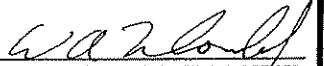
 MASSACHUSETTS BAY TRANSPORTATION AUTHORITY	RAILROAD OPERATIONS	DWG. NO. 1217	
		Oct. 28, 1992 <small>ISSUE DATE</small>	
TRACK DRIVE SPIKE			
 ENGINEERING OFFICER		 CHIEF ENGINEERING OFFICER	

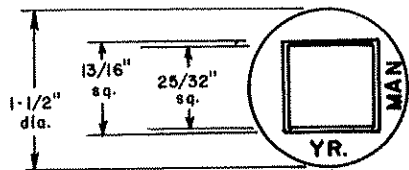

Designed for use with 13/16" socket.

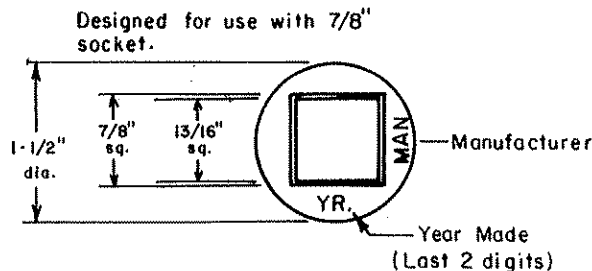

Designed for use with 7/8" socket.

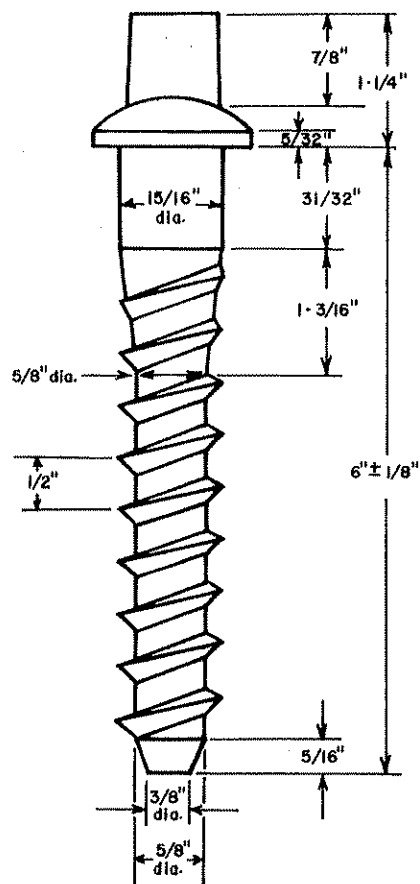

15/16" SCREW SPIKE

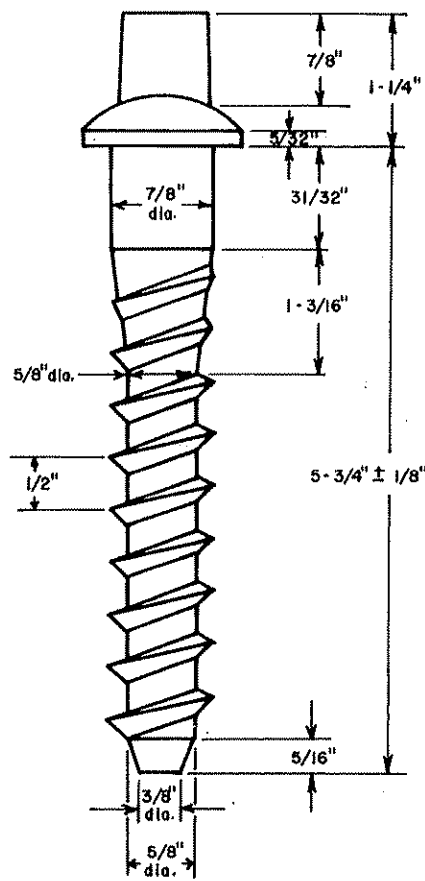

7/8" SCREW SPIKE

NOTES:

1. SCREW SPIKES SHALL BE FORGED FROM MEDIUM CARBON STEEL CONFORMING WITH ASTM A-66.
2. UNLESS OTHERWISE SPECIFIED, FURNISH 7/8" DIAMETER SCREW SPIKES
3. APPROXIMATE WEIGHT = 1.1 IBS.

T	MASSACHUSETTS BAY TRANSPORTATION AUTHORITY	RAILROAD OPERATIONS	DWG. NO. 1218
			Oct. 28, 1992 ISSUE DATE
SCREW SPIKES		<i>John B. Peay</i>	<i>W. A. Walsh</i>
ENGINEERING OFFICER		CHIEF ENGINEERING OFFICER	

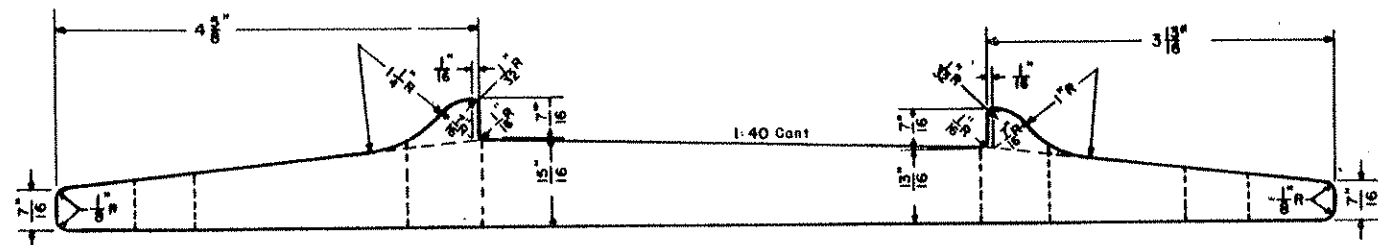
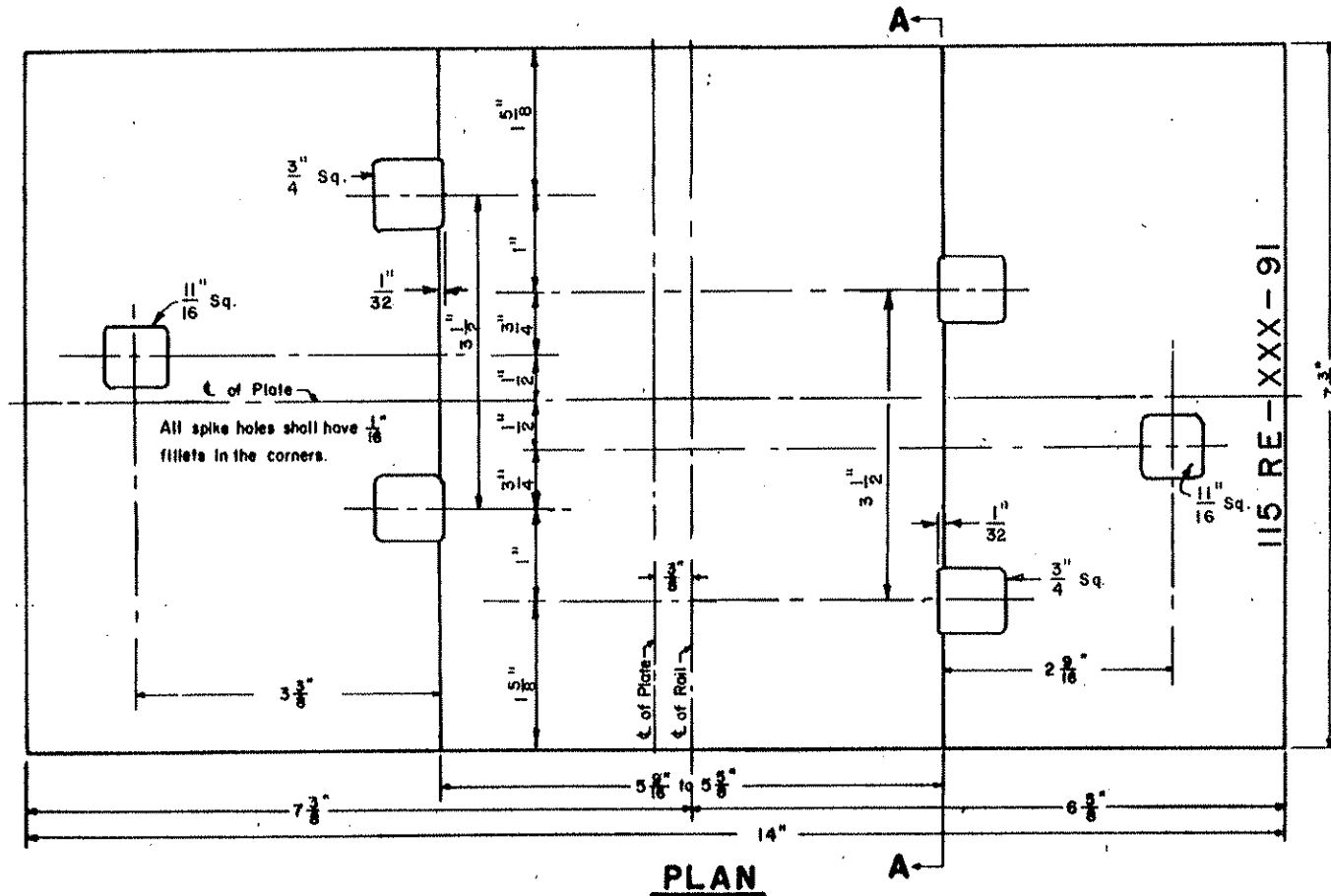

ELEVATION
 AREA PLAN NO. 8 WITH B-6 PUNCHING
 Calculated Weight 23.06 lbs.

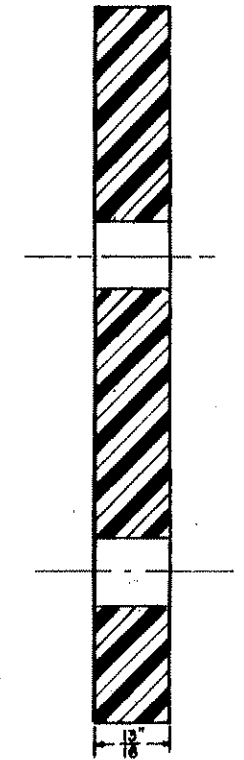

SECTION A-A

NOTES

The plates shall conform to the current AREA "Specifications for Low-Carbon Steel Tie Plates."
 The plates shall be branded with the figures 115 RE to designate the section, three letters or a trade mark to indicate the producer and two figures being the last two digits of the year rolled. Lettering shall be on the gage side of the plate.

T	MASSACHUSETTS BAY TRANSPORTATION AUTHORITY	RAILROAD	DWG. NO. 1220
		OPERATIONS	Oct. 28, 1992 ISSUE DATE
		TIE PLATE FOR 115LB RE RAIL	ISSUE NO. (2)
<i>John D. Ray</i> ENGINEERING OFFICER		<i>W. A. ...</i> CHIEF ENGINEERING OFFICER	

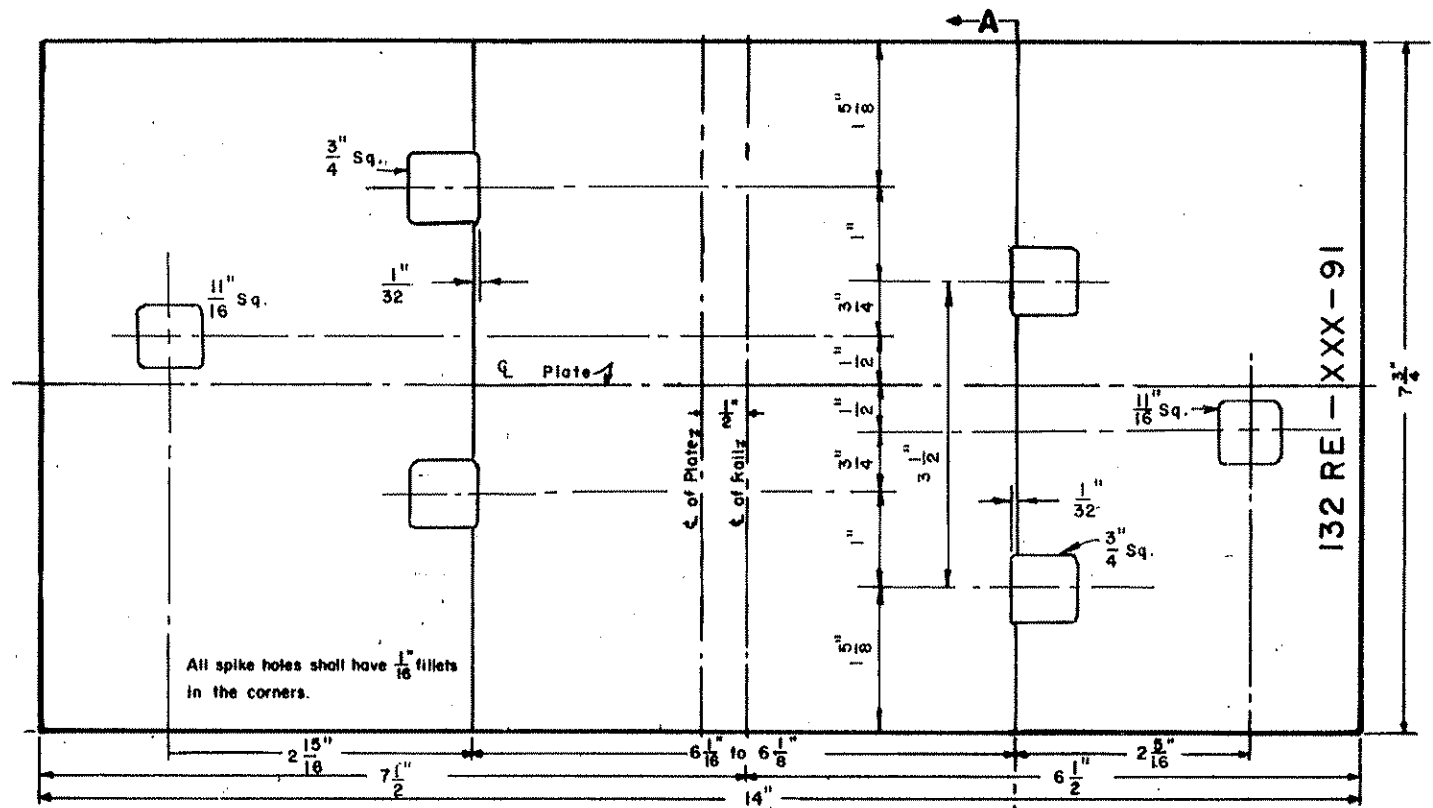

All spike holes shall have $\frac{1}{16}$ " fillets in the corners.

PLAN

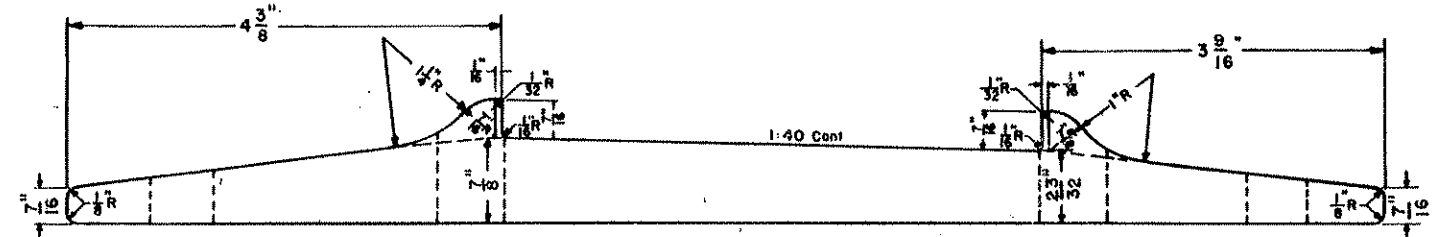

ELEVATION

Calculated Weight 21.62 lbs.

AREA PLAN NO. 12 WITH B-6 PUNCHING

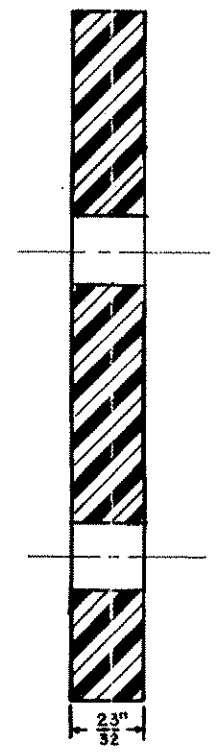

SECTION A-A

NOTES

Tie Plates shall conform to the current A.R.E.A. "Specifications For Low-Carbon Steel Tie Plates."

Tie Plates shall be branded with the figures 132 RE to designate the section; three letters or a trade mark to indicate the producer, and two figures being the last two digits of the year rolled. Lettering shall be on gage side of the plate.

T	MASSACHUSETTS BAY TRANSPORTATION AUTHORITY	RAILROAD OPERATIONS	DWG. NO. 1222
			Oct. 28, 1992 (2) ISSUE DATE ISSUE NO.

**TIE PLATE
FOR 132 LB RE RAIL**

John D. Ray
ENGINEERING OFFICER

W. A. ...
CHIEF ENGINEERING OFFICER

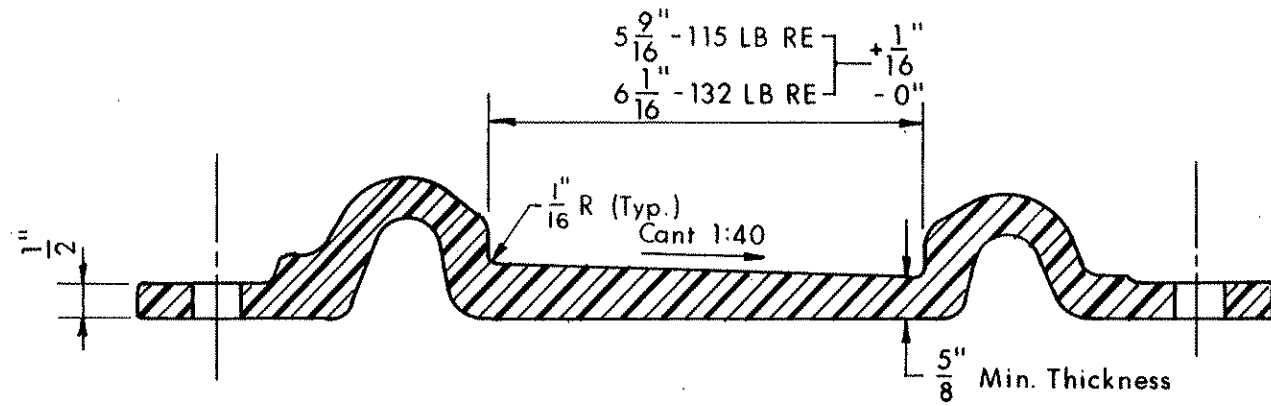

SECTION

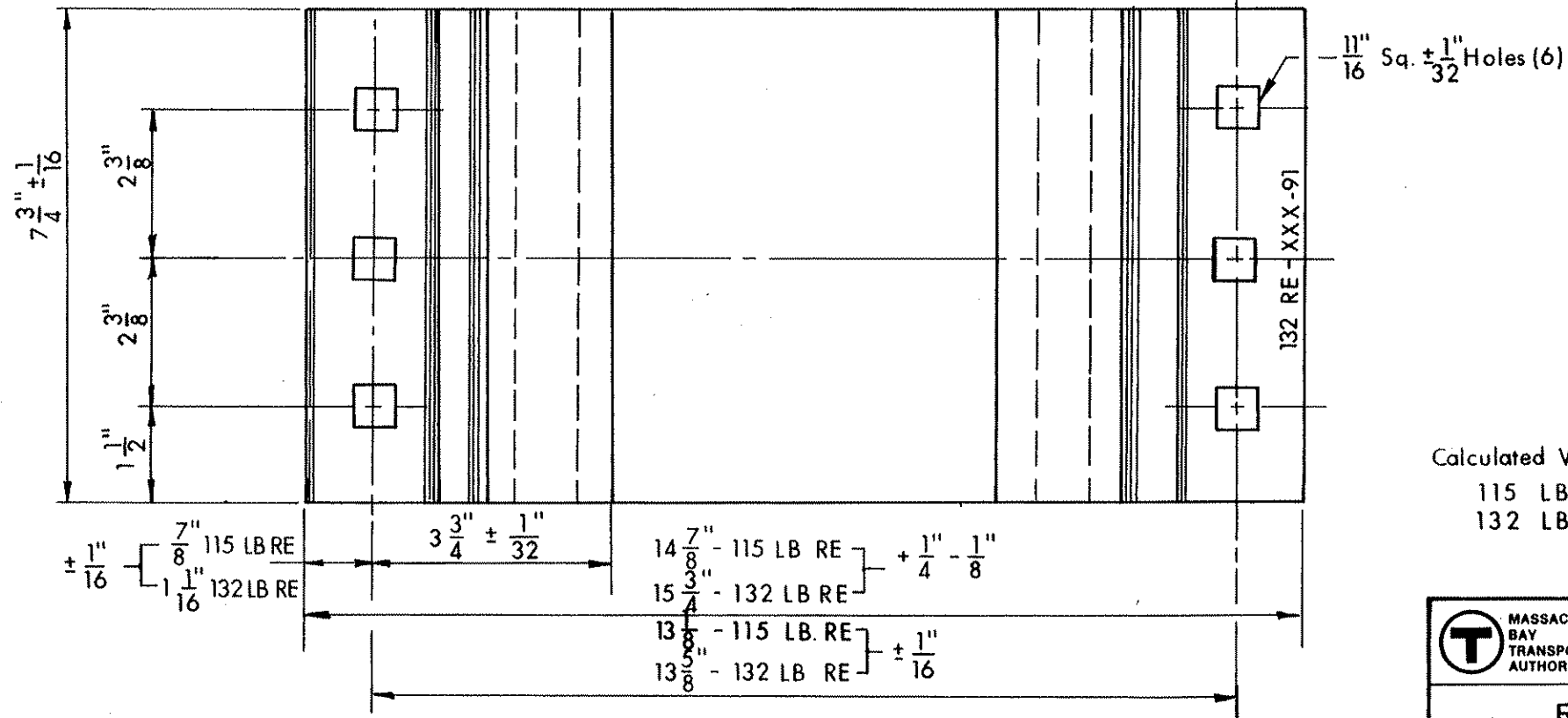

PLAN

NOTES:

1. Tie Plates shall conform to current A.R.E.A. Specifications.
2. Tie Plates shall be branded either 115 or 132 to designate the section, three letters or a trademark to indicate the producer and two figures being the last two digits of the year rolled. Lettering shall be on the gage side of the plate.
3. Material shall be Low - Carbon Steel.

Calculated Weight (Approx.) of Punched Plate

115 LB RE	-----	23.40 lbs.
132 LB RE	-----	24.48 lbs.

 MASSACHUSETTS BAY TRANSPORTATION AUTHORITY	RAILROAD OPERATIONS	DWG. NO. 1224
		Oct. 28, 1992 <small>ISSUE DATE</small>
RESILIENT FASTENER TIE PLATE FOR LOCK SPIKES		 <small>ENGINEERING OFFICER</small>
 <small>CHIEF ENGINEERING OFFICER</small>		<small>ISSUE NO.</small>

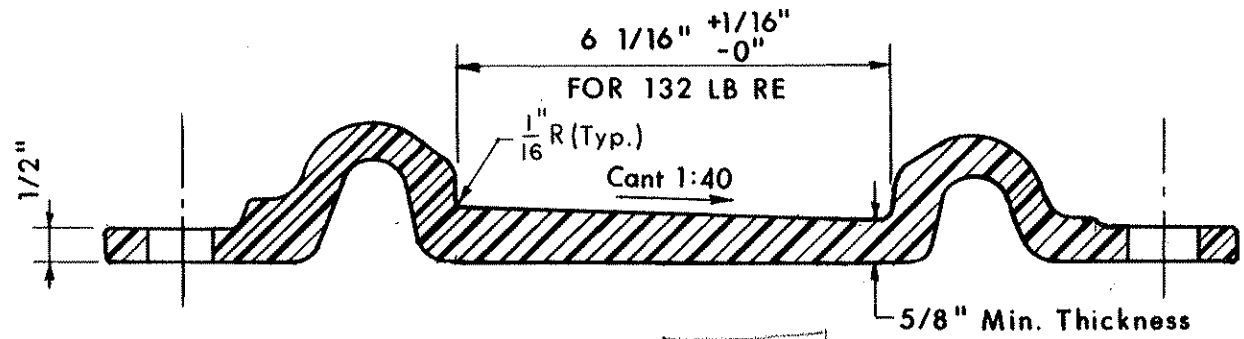

SECTION

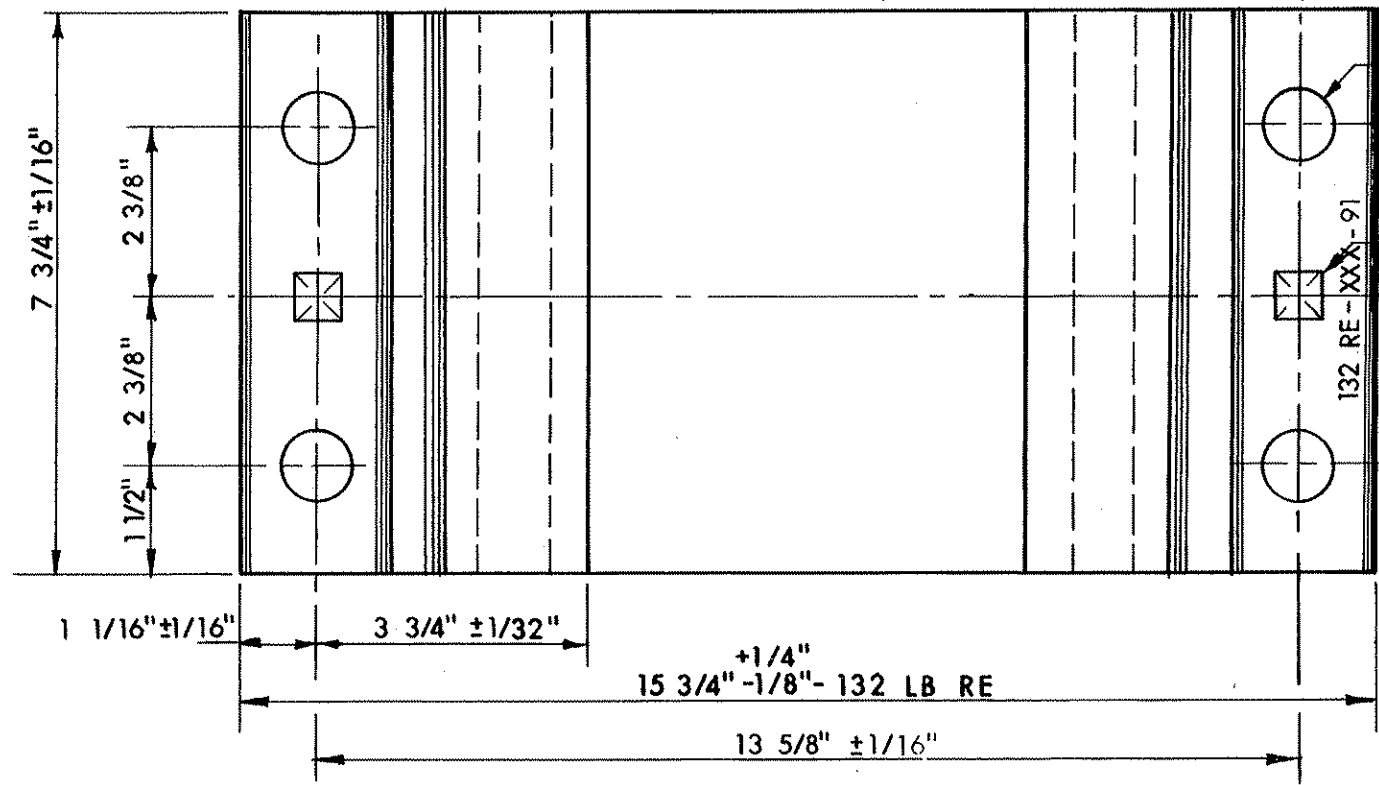

PLAN

Calculated Weight (Approx.) of Punched Plate
132 LB. R.E ---- 24.36 Lbs.

NOTES:

1. Tie Plates shall conform to current A.R.E.A. Specifications.
2. Tie Plates shall be branded 132 to designate the section, three letters or a trademark to designate the producer and two figures being the last two digits of the year rolled. Lettering shall be on the gage side of the plate.
3. Material shall be Low-Carbon Steel.

4. Outside holes shall be 15/16" dia. round holes to fit 7/8" dia. screw spikes.
- 2 Center holes marked shall be 11/16" sq. holes ±1/32"

T	MASSACHUSETTS BAY TRANSPORTATION AUTHORITY	RAILROAD OPERATIONS	DWG. NO. 1225	①
			Oct. 28, 1992 ISSUE DATE	
RESILIENT FASTENER TIE PLATE FOR SCREW SPIKES				
<i>John D. Roy</i> ENGINEERING OFFICER		<i>W. A. Wald</i> CHIEF ENGINEERING OFFICER		

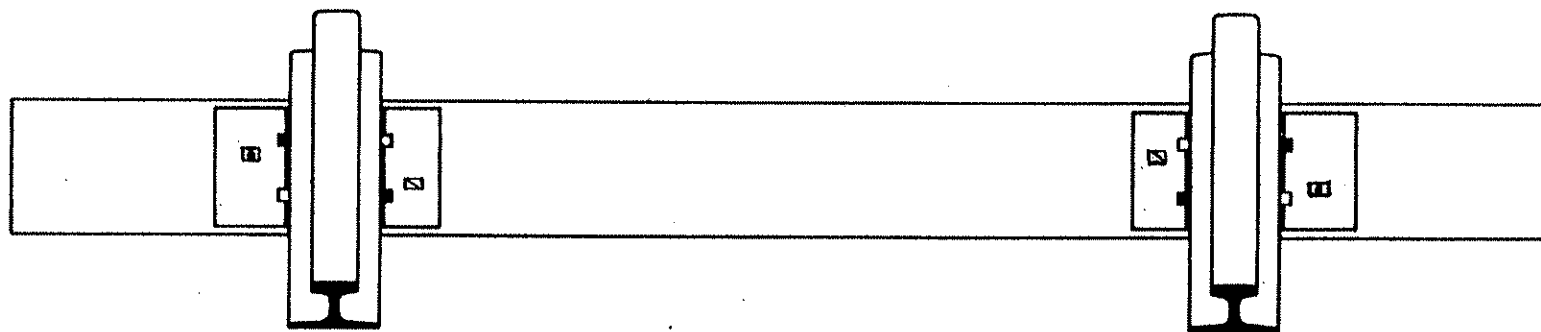

LEGEND

- Indicates Rail Holding Spikes in All Cases
- ☒ " 1st Plate Holding Spike (Where Only One Is Required).
- ② " 2nd Plate Holding Spike (Where Two Are Required).

Spike (both sides) heads to be turned 180° with insulated joints

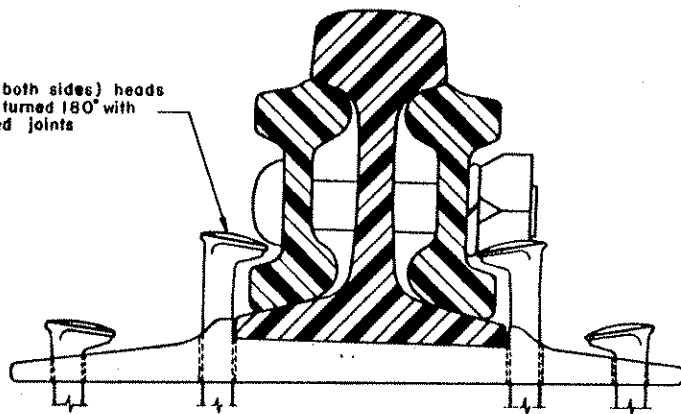

SPIKE APPLICATION WITHIN JOINT BAR LIMITS

Rail holding spikes shall have approximately $\frac{1}{8}$ " clearance between underside of head and top of base of rail.

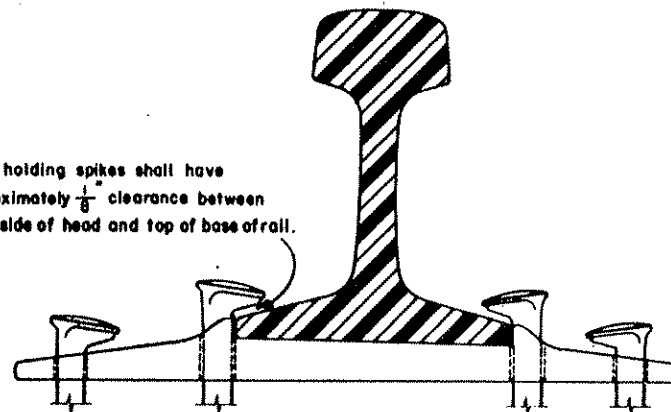

SPIKE APPLICATION OF RAIL AND PLATE HOLDING SPIKES

(Tangent and Curved Track)

NOTES:

1. Spiking on bridges and trestles shall be the same as for standard ballasted track.
2. For spiking patterns, see drawing NO. 1104

T	MASSACHUSETTS BAY TRANSPORTATION AUTHORITY	RAILROAD OPERATIONS	DWG. NO. 1230	②
			Oct. 28, 1992 ISSUE DATE	ISSUE NO.
SPIKING ARRANGEMENT FOR TIE PLATES				
<i>Julia D. Ray</i> ENGINEERING OFFICER		<i>W. A. ...</i> CHIEF ENGINEERING OFFICER		

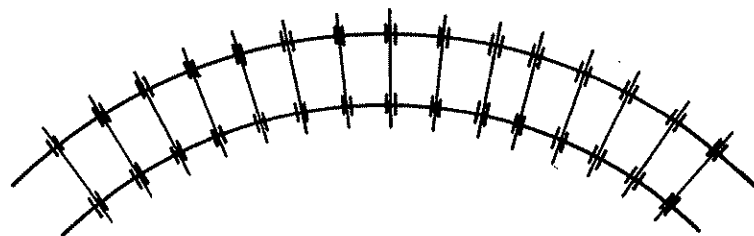

CWR WITH CURVES 3° AND OVER

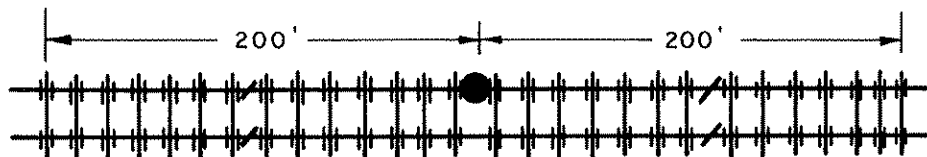

JOINED END OF CWR STRING

● INDICATES JOINT BARS

AT LOCATIONS WHERE CWR MEETS JOINED RAIL,
DO NOT APPLY ADDITIONAL ANCHORS TO
JOINED RAIL.



TYPICAL CONTINUOUS WELDED RAIL (CWR) STRING
(TANGENT & CURVATURE UP TO 3°)

RAIL ANCHORING PATTERNS FOR CONTINUOUS WELDED RAIL

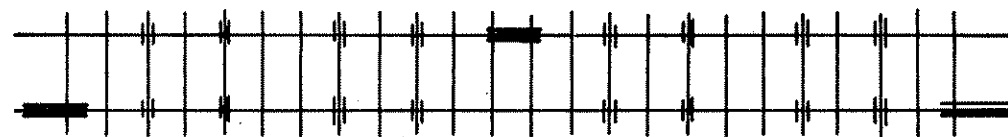

RAIL ANCHORING PATTERN FOR JOINED RAIL IN 39' LENGTHS WITH TRAFFIC
IN BOTH DIRECTIONS

(32 ANCHORS PER 39 FOOT LENGTH OF TRACK) ④ & ⑤

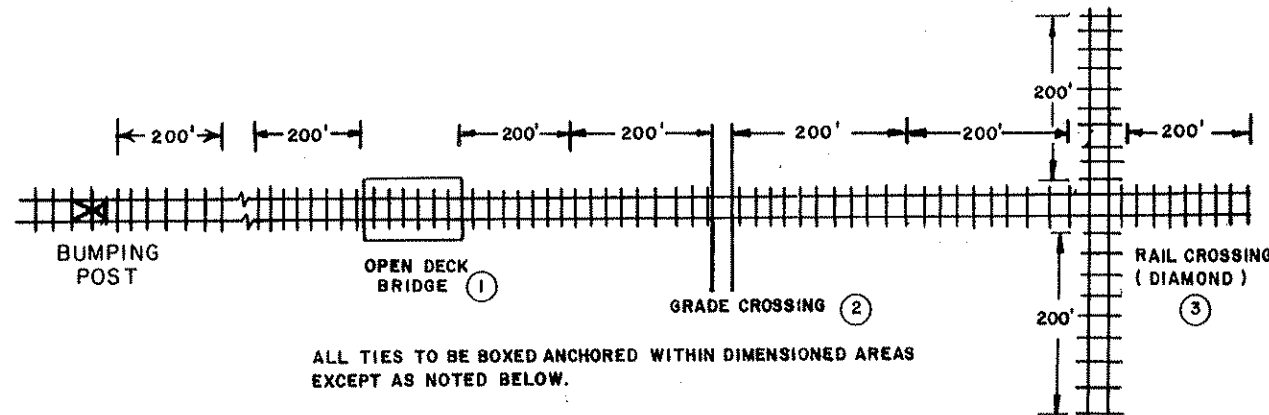

ALL TIES TO BE BOXED ANCHORED WITHIN DIMENSIONED AREAS
EXCEPT AS NOTED BELOW.

RAIL ANCHORING FOR OPEN DECK BRIDGES, GRADE AND RAIL CROSSINGS
AND BUMPING POSTS WITH C.W.R. OR JOINED RAIL

Anchoring Patterns Shown are for Cut-Spike Fastened Track. Rail Fastened with Approved Resilient Fasteners Does Not Need Anchors As Shown on This Drawing.

NOTES

1. OPEN DECK OR THROUGH DECK BRIDGES ARE NOT TO BE ANCHORED ACROSS THE SPAN EXCEPT UNDER THE PROVISIONS OF THE MBTA'S MW-1 OR WITH AUTHORIZATION OF THE CHIEF ENGINEER.
2. GRADE CROSSINGS ARE NOT TO BE ANCHORED WITHIN THE LIMITS OF THE PAVED OR RUBBER AREA.
3. THE DIAMOND FROGS ARE NOT TO BE ANCHORED.
4. JOINED RAIL ANCHORING PATTERN TO BE ADJUSTED FOR JOINT SPACING WHERE NECESSARY
5. JOINED RAIL ANCHORING TO BE ADJUSTED FOR DIFFERING RAIL LENGTHS

T	MASSACHUSETTS BAY TRANSPORTATION AUTHORITY	RAILROAD OPERATIONS	DWG. NO. 1232
			Oct. 28, 1992 ISSUE DATE
		① ISSUE NO.	
RAIL ANCHORING DETAILS - JOINED AND CWR TRACK			
<i>John D. Ray</i> ENGINEERING OFFICER		<i>W. A. ...</i> CHIEF ENGINEERING OFFICER	

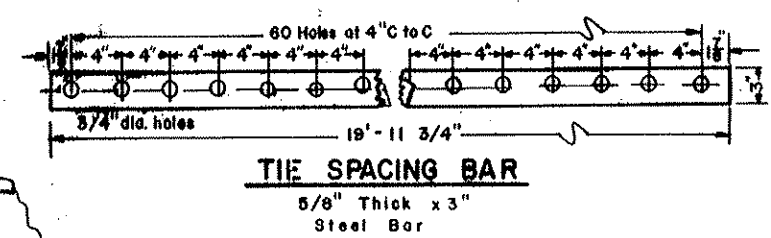
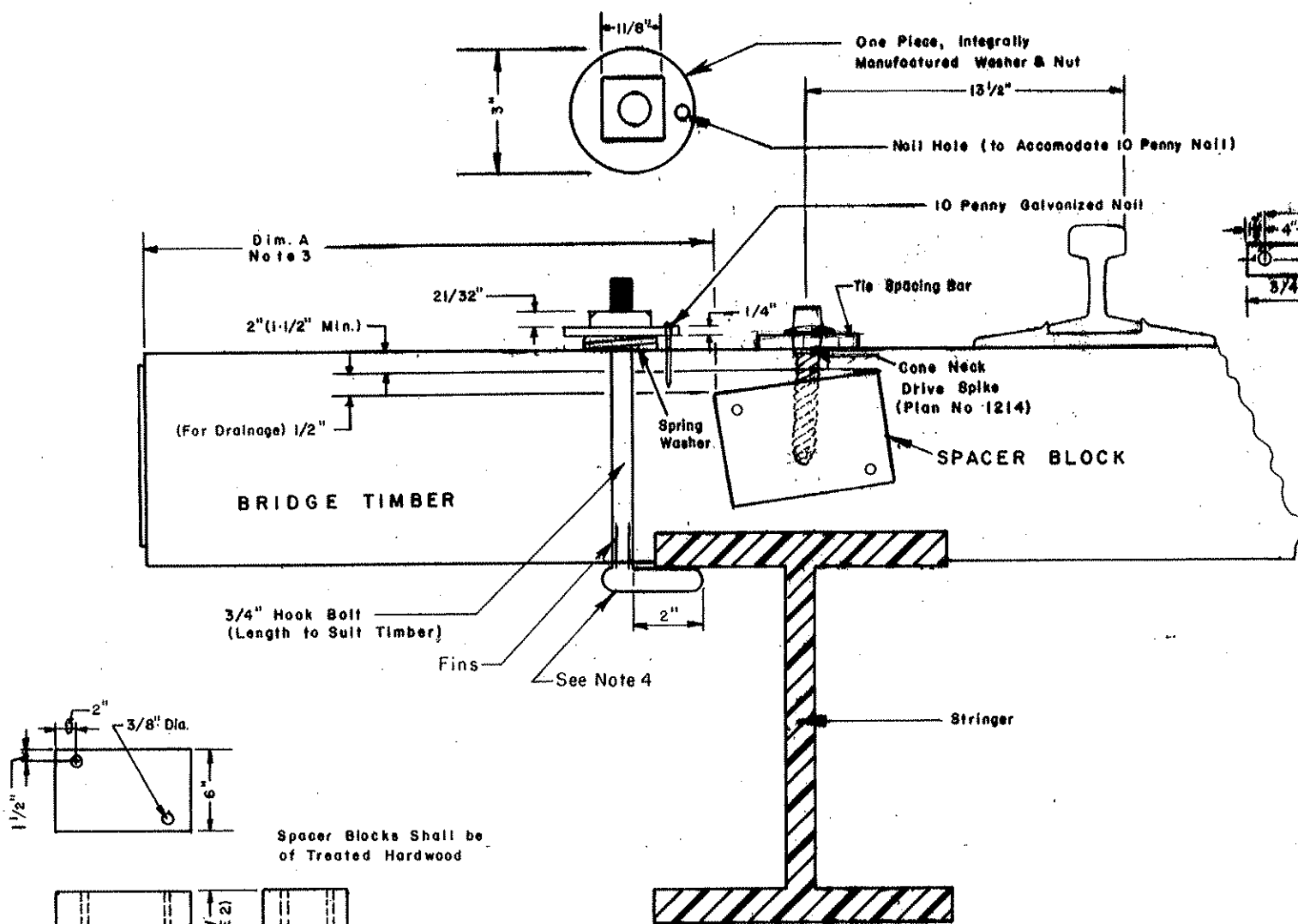

NOTES :

1. SEE MBTA'S MW-1 MANUAL FOR ADDITIONAL INFO.
2. WIDTH OF SPACER BLOCK (W) VARIES TO MEET TIMBER SPACING AND THICKNESS, PREFERRED SPACING IS 16" C-C USING 9" WIDE TIMBERS (W=7").
3. LOCATE SPACER BLOCKS AS CLOSE TO FIELD SIDE OF RUNNING RAIL AS POSSIBLE.
4. USE "HOOK BOLT PLATE" WHERE COVER PLATE OR STEEL FLANGES ARE TOO THICK TO ALLOW THE FINS TO HOLD THE BRIDGE TIES.

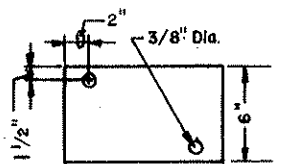

Spacer Blocks Shall be of Treated Hardwood

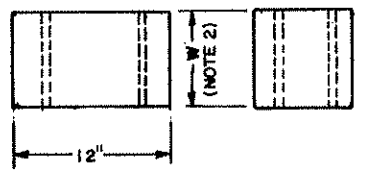

SPACER BLOCKS

DETAIL OF HOOK BOLTS USED AS BRIDGE TIMBER ANCHOR

	MASSACHUSETTS BAY TRANSPORTATION AUTHORITY	RAILROAD OPERATIONS	DWG. NO. 1236
			Jan. 5, 1996 ISSUE DATE

BRIDGE TIMBER ANCHORING DETAIL

John D. Ray
SECTION CHIEF

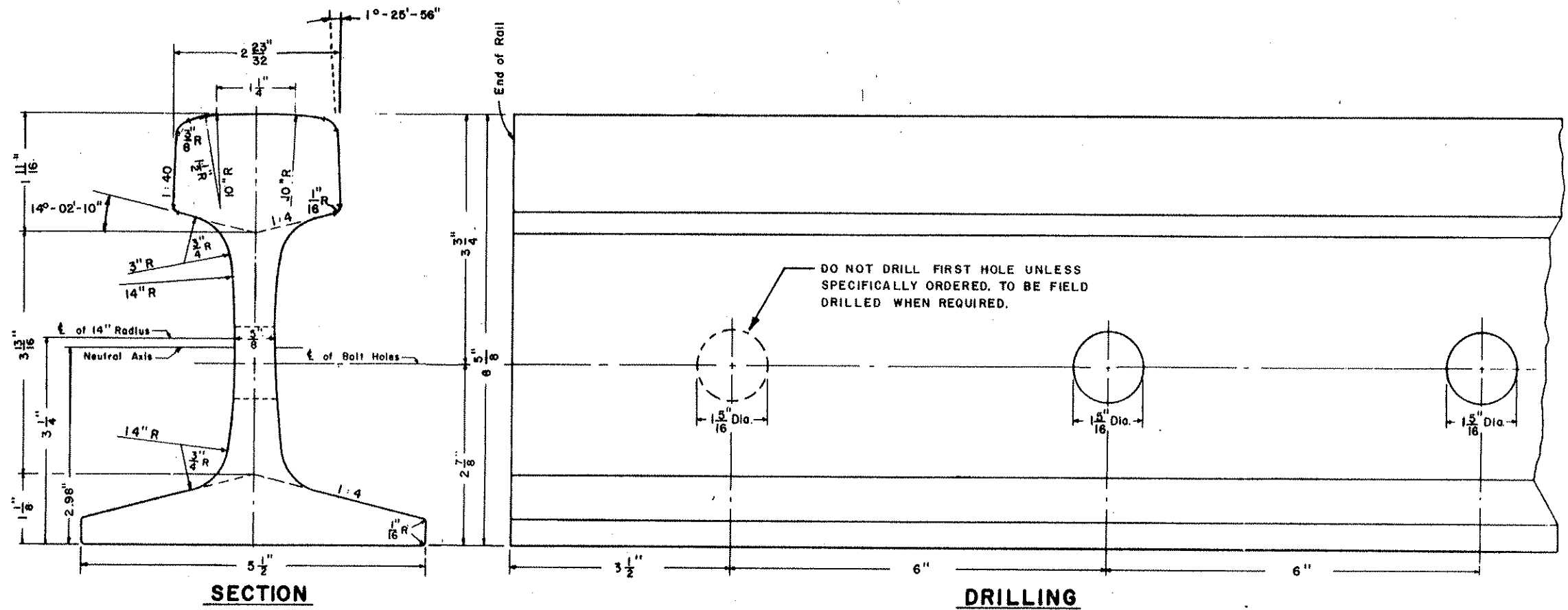

Rails shall be in accordance with current A.R.E.A. "Specifications for Steel Rails," except all rails within special trackwork shall be fully heat treated

MINIMUM MATHEMATICAL ATTRIBUTES

	Area Sq. In.	Percent		
Head	3.91	34.8	Moment of Inertia	65.6
Web	3.04	27.1	Sec. Modulus of Head	18.0
Base	4.29	38.1	Sec. Modulus of Base	22.0
Total	11.25	100.0	Ratio M.I. to Area	5.83
			Ratio Sec. Modulus Head to Area	1.60
			Ratio Height to Base	1.20
			Weight per Yard	114.7
			Net Tons per Mile of Track	201.87

	RAILROAD OPERATIONS	DWG. NO. 1300
		Oct. 28, 1992 2 <small>ISSUE DATE ISSUE NO.</small>
<h2>115 LB R E RAIL</h2>		
 ENGINEERING OFFICER	 CHIEF ENGINEERING OFFICER	

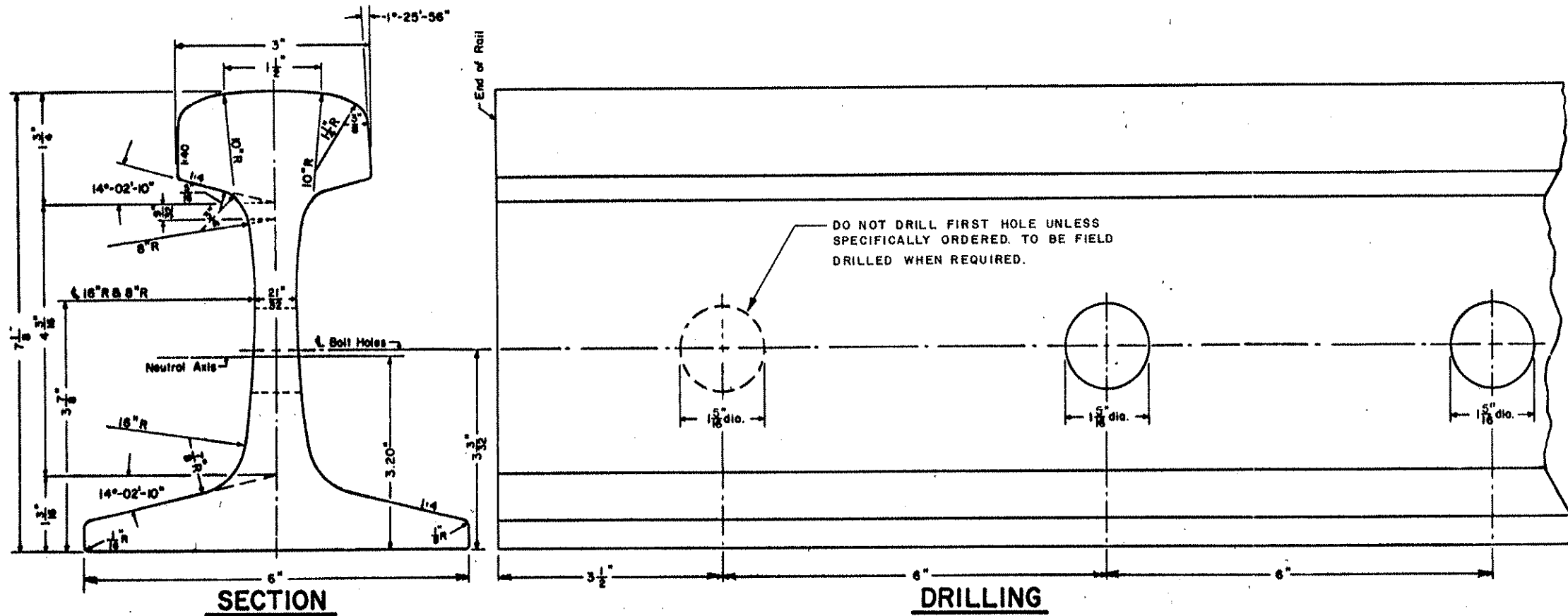

SECTION

DRILLING

MINIMUM MATHEMATICAL ATTRIBUTES

Area Sq. in.	Percent	Moment of inertia-----	88.2	
Head-----	4.42	34.1	Section modulus, head-----	22.5
Web-----	3.66	28.3	Section modulus, base-----	27.6
Base-----	4.87	37.6	Ratio m. i. to area-----	6.81
Total-----	12.95	100.0	Ratio s. m. head to area-----	1.74
			Ratio height to base-----	1.19
			Calculated weight, lbs. per yard-----	132.1
			Net Tons per Mile of Track-----	232.50

Rails shall conform to current A.R.E.A. "Specification For Open Hearth Steel Rails," except all rails within special trackwork shall be fully heat treated.

 MASSACHUSETTS BAY TRANSPORTATION AUTHORITY	RAILROAD OPERATIONS	DWG. NO. 1302
		Oct. 28, 1992
132 LB R E RAIL		
<i>John D. Ray</i> ENGINEERING OFFICER		<i>W. W. ...</i> CHIEF ENGINEERING OFFICER

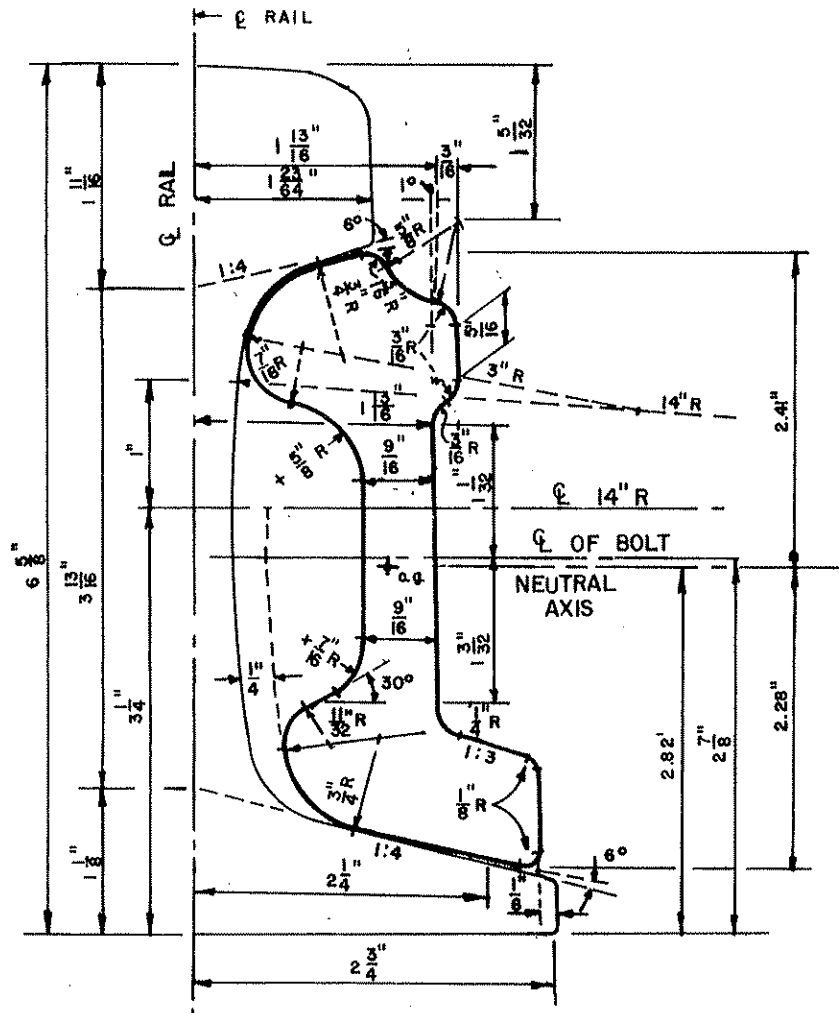

SECTION

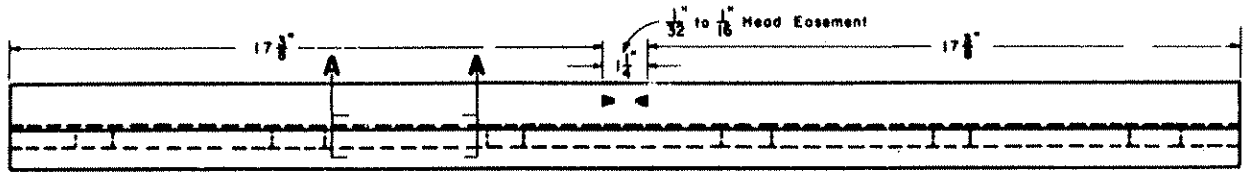

PLAN

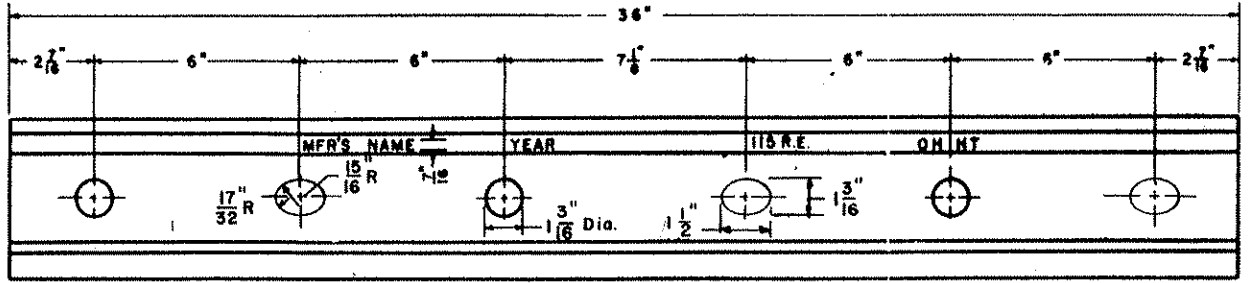

ELEVATION

**MINIMUM
MATHEMATICAL ATTRIBUTES
(TWO BARS)**

Moment of Inertia.....	20.6
Section Modulus above Neutral Axis.....	8.5
Section Modulus below Neutral Axis.....	9.0
Calculated Weight of 2 Bars.....	93.8 Lbs
Area in Square inches (1 Bar).....	4.70 sq. in.

1/8" Joint Bars shall be Short Toe and a Headfree Design.
1/8" Elliptical Neck Bolts to be used with this bar.

Joint Bars shall be in accordance with the current A.R.E.A.
"Specifications for Quenched Carbon Steel Joint Bars."

T	MASSACHUSETTS BAY TRANSPORTATION AUTHORITY	RAILROAD OPERATIONS	DWG. NO. 1320
			Oct. 28, 1992 (2) ISSUE DATE ISSUE NO.
115 LB RE JOINT BAR			
<i>John D. Reay</i> ENGINEERING OFFICER		<i>W. A. Wolf</i> CHIEF ENGINEERING OFFICER	

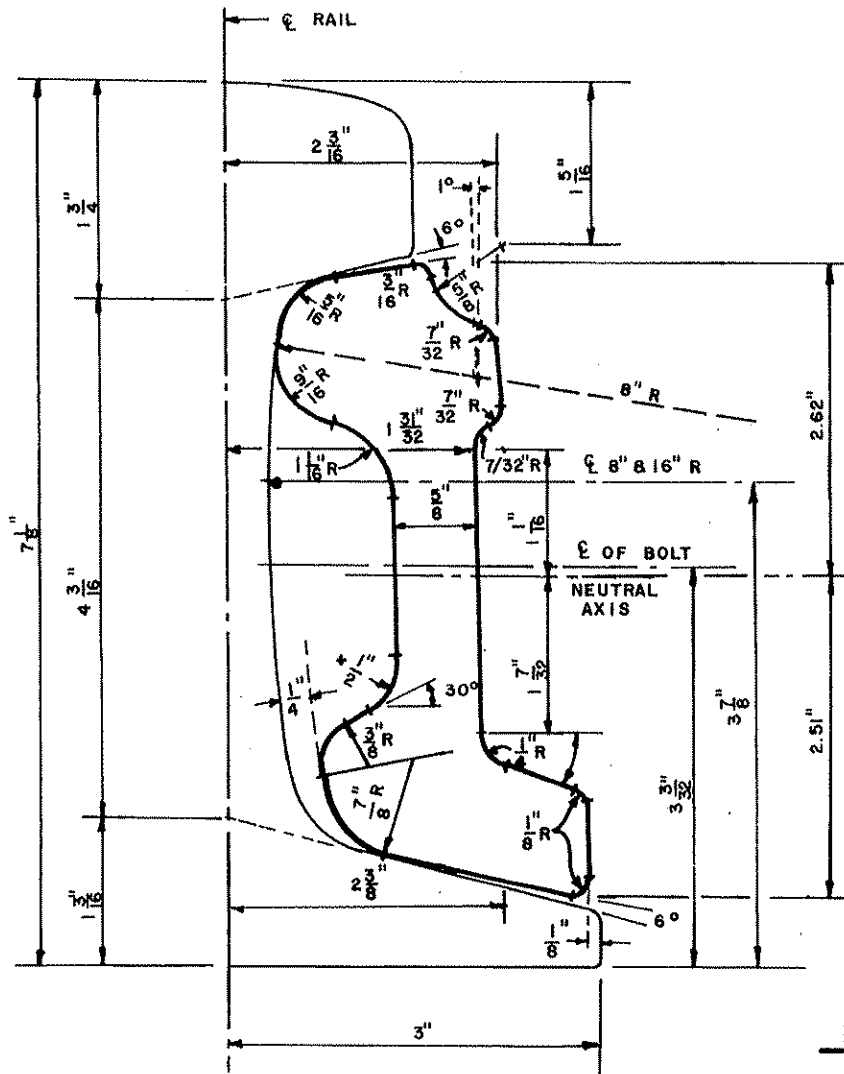

SECTION

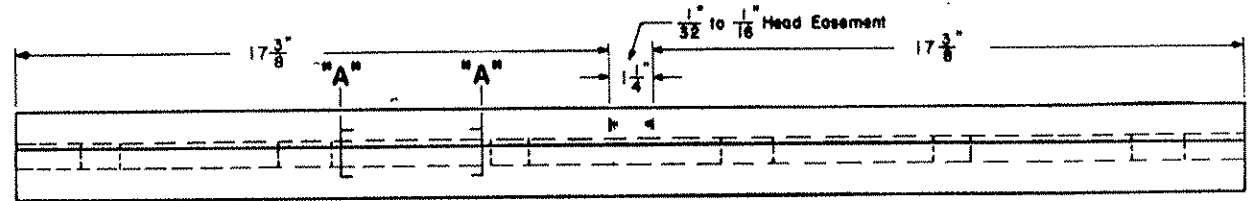

PLAN

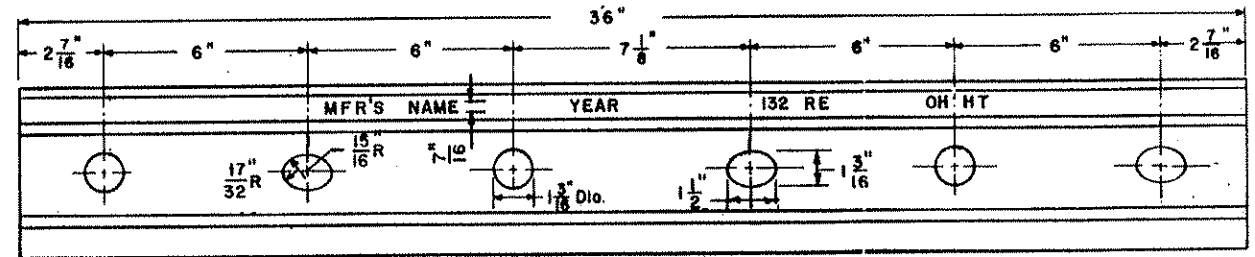

ELEVATION

**MINIMUM
MATHEMATICAL ATTRIBUTES
TWO BARS**

Moment of Inertia-----	31.8
Section Modulus above Neutral Axis-----	13.2
Section Modulus below Neutral Axis-----	12.0
Calculated Weight of 2 Bars-----	117.71 Lbs.
Area in Square Inches (1 Bar)-----	5.52 sq. in.

Joint Bars shall be Short Toe and a Headfree Design.
 Joint Bars shall be in accordance with the current A.R.E.A.
 "Specifications For Quenched Carbon Steel Joint Bars."
 1 1/8" Elliptical Neck Bolts to be used with this bar.

T	MASSACHUSETTS BAY TRANSPORTATION AUTHORITY	RAILROAD OPERATIONS	DWG. NO. 1322
			Oct. 28, 1992 (2) ISSUE DATE ISSUE NO.
132 LB RE JOINT BAR			
<i>John P. Ray</i> ENGINEERING OFFICER		<i>W. A. ...</i> CHIEF ENGINEERING OFFICER	

Planned off to provide wheel clearance on rail of lesser section depth or lighter rail.
 Joint with "No Hand" both bars are to be planned.
 Joint with "Hand" only gage bar is to be planned.

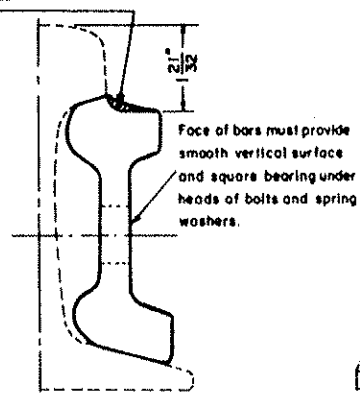

SECTION A-A

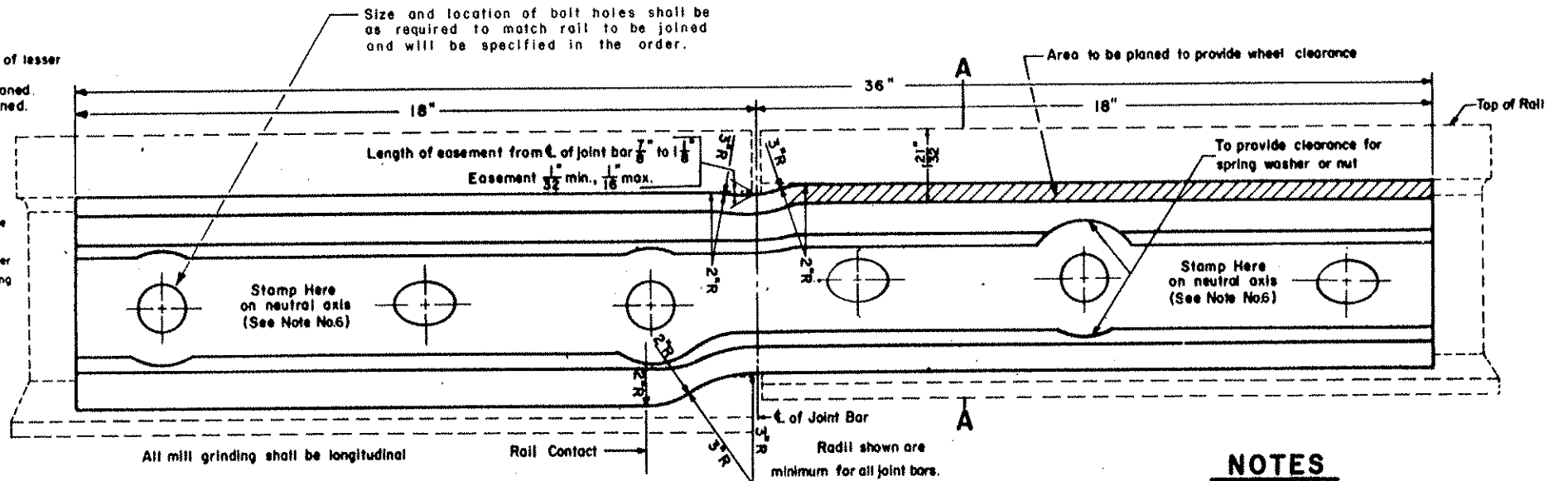

NOTES

1. All joint bars shall conform to current AREA specifications for Quenched Carbon Steel Joint Bars.
2. One joint shall consist of two bars. The joint bars shall be furnished without any provisions for any wear in the rail.
3. Joint bars shall be ordered 36" long without exception unless specifically directed otherwise by the Chief Engineering Officer.
4. Joint bars shall be forged, heat treated and shaped to the configuration of standard joint bars of the respective rail sections to be joined.
5. All bars must be furnished so that the distance between other faces of the bars will be the same as for standard joint bar for the respective rail sections so joint bolts of standard lengths can be used.
6. All bars shall be stamped with depressed characters not less than $\frac{1}{8}$ " in height to show the manufacturer's name or trademark, year manufactured, and connecting rail sections at each end. Bars for joints that have "No Hand" shall be stamped "RHO-LHG" or "RHG-LHO" to indicate interchangeability. Bars for joints "With a Hand" shall be stamped "LHG", "RHG", "LHO", or "RHO", whichever applies, see sketch at left. All stamping shall be placed so as to not be covered by the bolt heads or the nuts.

ALLOWABLE COMPROMISES

- 100 - 85
- 107 - 85
- 107 - 100
- 112 - 100
- 112 - 107
- 115 - 100
- 115 - 107
- 115 - 112
- 132 - 115
- 136 - 115
- 136 - 132

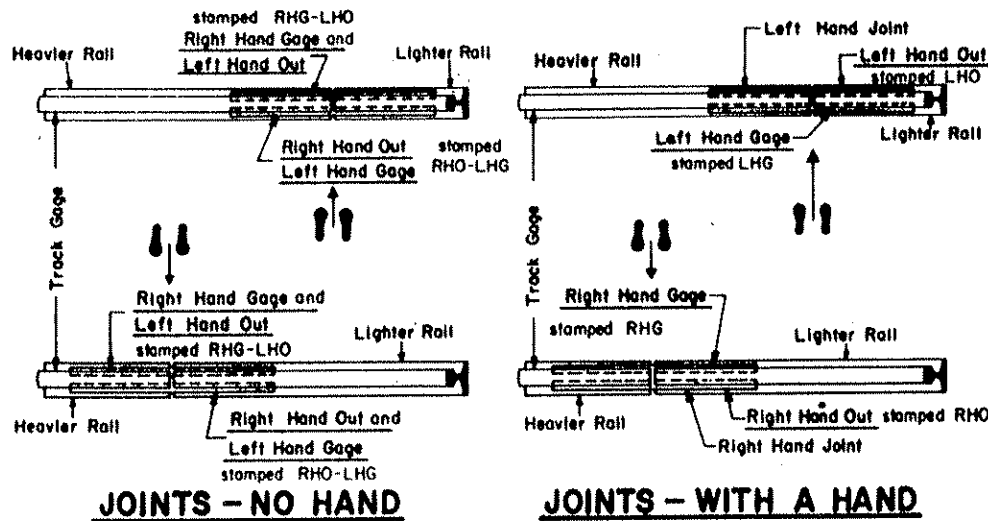

Proper designations for joint bars are shown underlined

TO DETERMINE HAND OF JOINT BAR

Stand between the rails (gage) of a track and face rails to be connected, **ORDER** -
LEFT HAND JOINT - when the heavier rail is on your left.
RIGHT HAND JOINT - when the heavier rail is on your right.

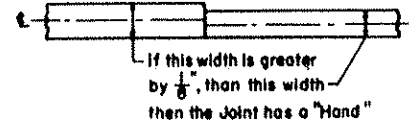
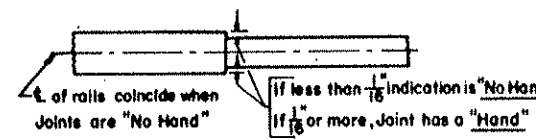

Even though the width of the rail heads are equal or within the limits specified above, the indication is a "Hand" if one rail is vertical and one rail is canted.

	MASSACHUSETTS BAY TRANSPORTATION AUTHORITY	RAILROAD OPERATIONS	DWG. NO. 1328 Oct. 28, 1992 ISSUE DATE	ISSUE NO. (2)
	COMPROMISE JOINT BARS FOR TEE RAIL			
John D. Ray ENGINEERING OFFICER		[Signature] CHIEF ENGINEERING OFFICER		

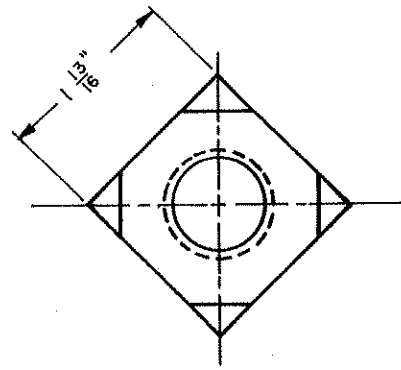

NUT

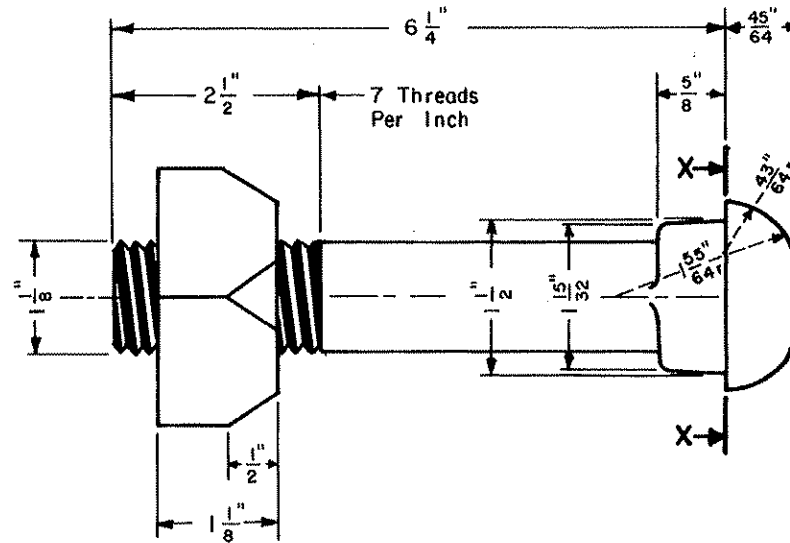

1/8" TRACK BOLT
(ELLIPTICAL NECK)

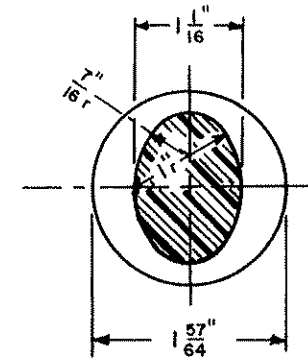

SECTION X-X

NOTES

- 1-All bolts, nuts and spring washers shall conform with current A.R.E.A. Specifications
- 2-All threads to be rolled threads.
- 3-All nuts to be wrench fit
- 4-All bolts, nuts and spring washers to be thoroughly coated with a metal preservative.

	MASSACHUSETTS BAY TRANSPORTATION AUTHORITY	RAILROAD OPERATIONS	DWG. NO. 1332
			Oct. 28, 1992 <small>ISSUE DATE</small>
STANDARD TRACK BOLT			 <small>ISSUE NO.</small>
 JOHN D. ROY <small>ENGINEERING OFFICER</small>		 W. A. HALL <small>CHIEF ENGINEERING OFFICER</small>	

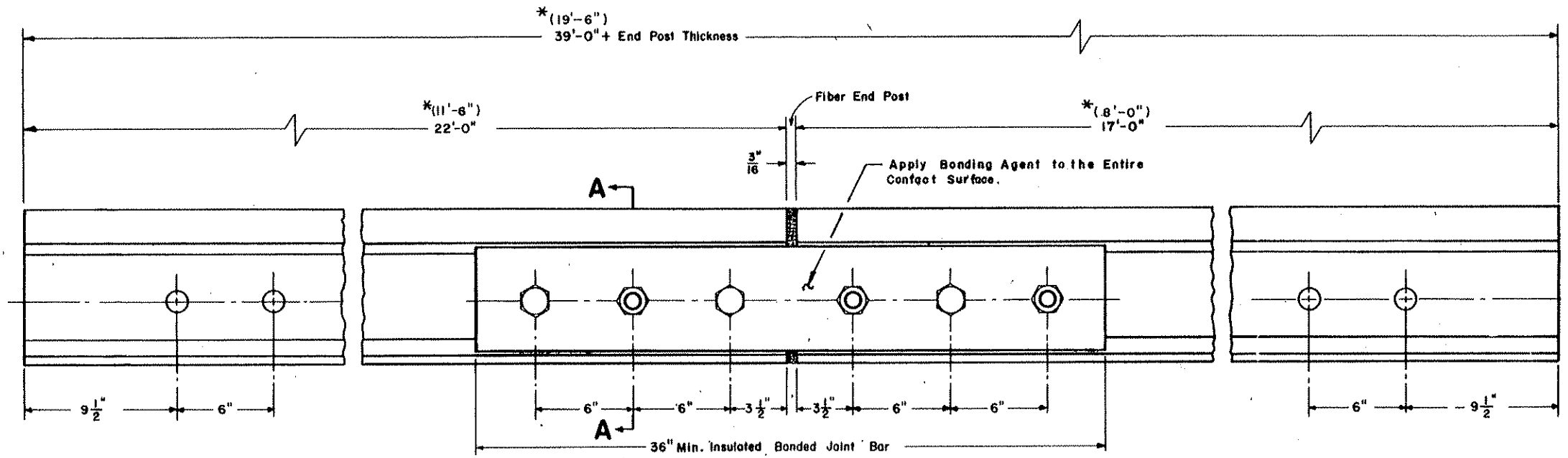

SIDE VIEW

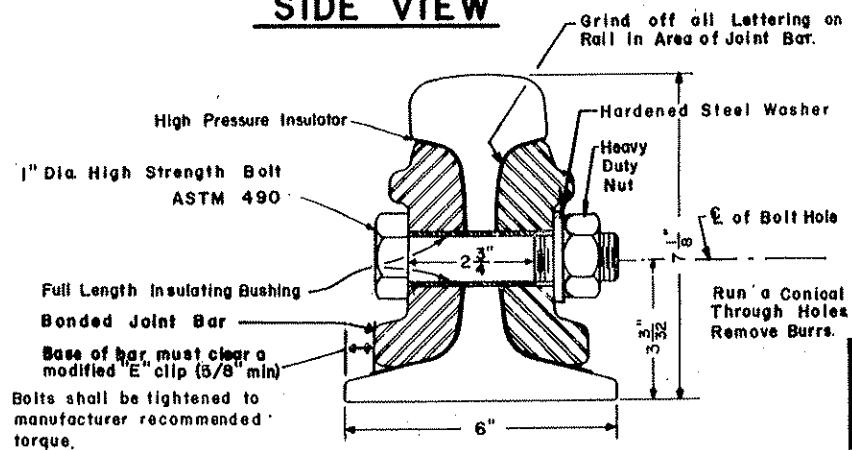

SECTION A-A

Alleghey..... 1050 ft. lbs
 Portec..... 1050 " "

MINIMUM MATHEMATICAL ATTRIBUTES

Avg. Area	6.40 sq. in.
Moment of Inertia	12.40
Section Mod. - Top	4.86
Section Mod. - Bottom	4.90

NOTES

- 1- All rails to be Fully Heat Treated
- 2- End bolt holes in the rail shall be $1\frac{5}{16}$ " dia.
- 3- Bolt heads to be installed in bar, in alternate positions.
- * 4- Supply 19'-6" long sections for new installations and 39'-0" long sections for replacements.
- 5- When spiking joint, place head in reverse position.
- 6- With Resilient Fastener Plates, use a Modified 'E' Clip, (2063A) - With Concrete Ties, include a modified 4263 insulator.

T	MASSACHUSETTS BAY TRANSPORTATION AUTHORITY	RAILROAD OPERATIONS	DWG. NO. 1340
		Oct. 28, 1992	(2) ISSUE NO.

132 R.E. BONDED INSULATED JOINT

John D. Reay ENGINEERING OFFICER *W. A. R. ...* CHIEF ENGINEERING OFFICER

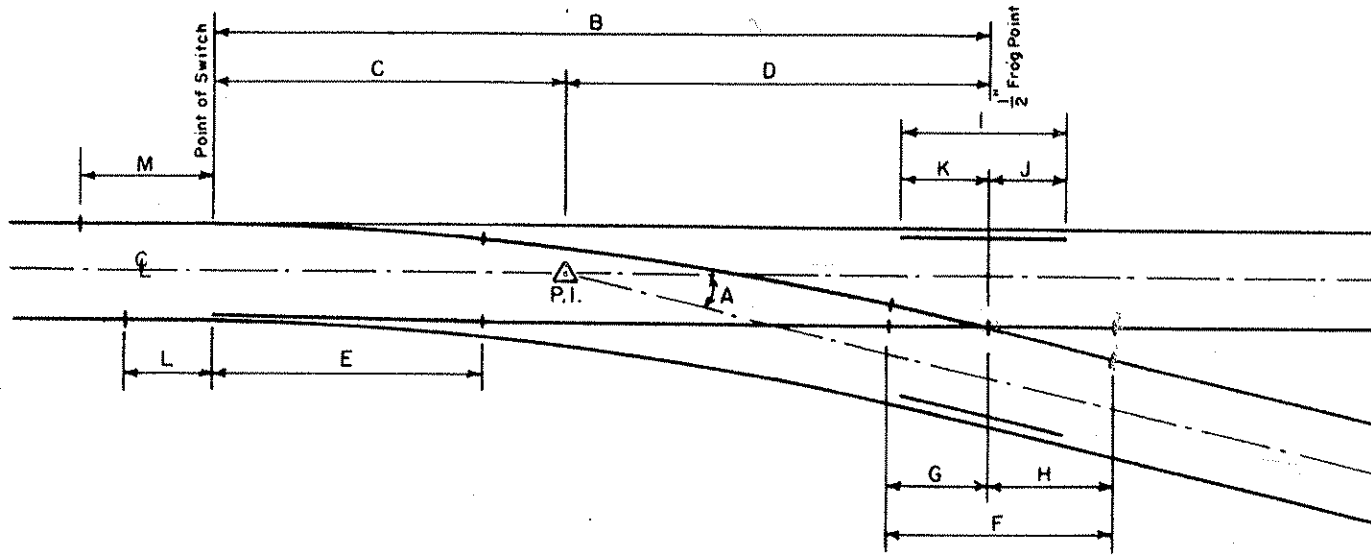

- A = Frog angle
 - B = Actual lead
 - C = Point of intersection to point of switch
 - D = Point of intersection to $\frac{1}{2}$ frog point
 - E = Length of straight switch point (② curved point)
 - F = Length of frog
 - G = Toe length
 - H = Heel length
 - I = Guard rail length
 - J = $\frac{1}{2}$ " frog point to end of guard rail
 - K = $\frac{1}{2}$ " frog point to end of guard rail
 - L = Point of switch to end of stock rail
 - M = Point of switch to end of stock rail
- FROG DIMENSIONS SHOWN ARE FOR WELDED, RAIL-BOUND MANGANESE STEEL FROG.

TURNOUT NUMBER	ANGLE	DIMENSION													
		A	B	C	D	E	F	G	H	I	J	K	L	M	L
6①	9°-31'-38"	47'-6"	19'-0"	28'-6"	11'-0"	12'-6"	5'-1"	7'-5"	10'-0"	3'-8 $\frac{1}{2}$ "	6'-3 $\frac{1}{2}$ "	4'-6"	6'-2"	-	-
8	7°-09'-10"	68'-0"	30'-0"	38'-0"	16'-6"	18'-0"	7'-0"	11'-0"	10'-0"	3'-8 $\frac{1}{2}$ "	6'-3 $\frac{1}{2}$ "	4'-6"	6'-2"	-	-
10	5°-43'-29"	77'-4 $\frac{3}{4}$ "	29'-10 $\frac{3}{4}$ "	47'-6"	16'-6"	23'-0"	9'-8"	13'-6"	13'-3"	6'-3 $\frac{1}{2}$ "	6'-11 $\frac{1}{2}$ "	4'-6"	6'-2"	14'-7 $\frac{1}{2}$ "	10'-5"
15	3°-49'-06"	111'-2 $\frac{3}{4}$ "	39'-11 $\frac{3}{4}$ "	71'-3"	②26'-0"	26'-8"	10'-4"	16'-4"	13'-3"	5'-4"	7'-11"	4'-6"	8'-0"	5'-0"	8'-9 $\frac{1}{4}$ "
20	2°-51'-51"	154'-6 $\frac{1}{2}$ "	59'-6 $\frac{1}{2}$ "	95'-0"	②39'-0"	34'-2"	13'-1"	21'-1"	13'-3"	6'-4"	7'-11"	6'-4"	6'-4"	5'-7 $\frac{1}{2}$ "	9'-0 $\frac{1}{2}$ "

① Requires special approval.

② Curved Switch

STANDARD TURNOUTS

SOLID HEEL BLOCK TURNOUTS	FLOATING HEEL BLOCK TURNOUTS
---------------------------	------------------------------

	MASSACHUSETTS BAY TRANSPORTATION AUTHORITY	RAILROAD OPERATIONS	DWG. NO. 2000
			Oct. 28, 1992
			ISSUE DATE
			ISSUE NO ②

STANDARD TURNOUTS
GENERAL LAYOUT

John D. Ray
ENGINEERING OFFICER

W. A. [Signature]
CHIEF ENGINEERING OFFICER

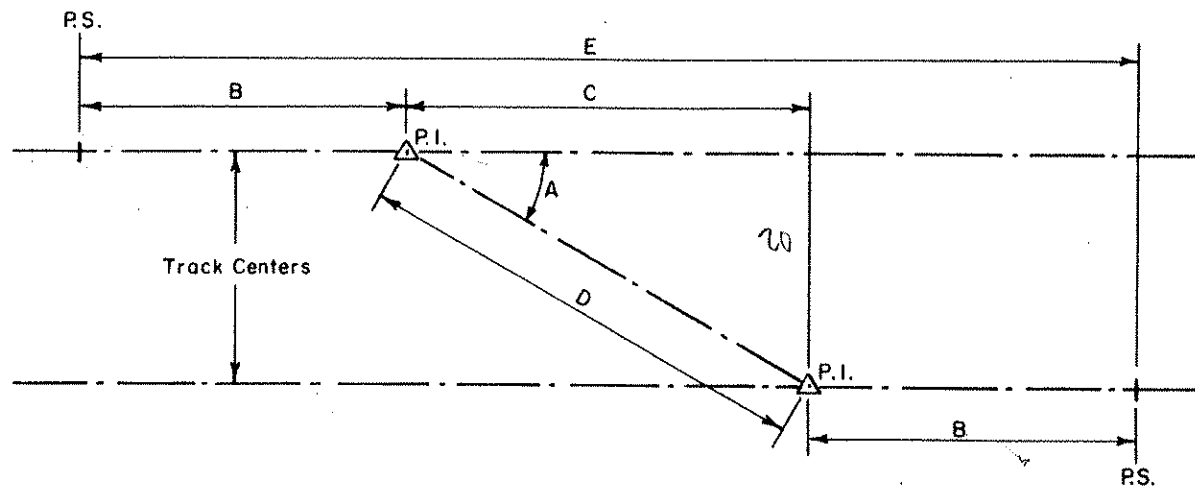

FOR TRACK CENTERS OTHER THAN SHOWN IN TABLE,

- C = Track Centers \div Tangent Angle A
- D = Track Centers \div Sine Angle A
- E = Dimension C + 2B

FROG #	TANGENT	SINE
6	0.167831	0.165516
8	0.125492	0.124516
10	0.100254	0.099754
15	0.066741	0.066593
20	0.050031	0.049968

TRACK CENTERS MUST BE IN DECIMALS OF A FOOT.

TURNOUT NUMBER	ANGLE A	B	C			D			E		
			Track Centers			Track Centers			Track Centers		
			12'-0"	13'-0"	14'-0"	12'-0"	13'-0"	14'-0"	12'-0"	13'-0"	14'-0"
6	9°-31'-38"	19'-0"	71'-6"	77'-5 $\frac{1}{2}$ "	83'-5"	72'-6"	78'-6 $\frac{1}{2}$ "	84'-7"	109'-6"	115'-5 $\frac{1}{2}$ "	121'-5"
8	7°-09'-10"	30'-0"	95'-7 $\frac{1}{2}$ "	103'-7 $\frac{1}{8}$ "	111'-6 $\frac{3}{4}$ "	96'-4 $\frac{1}{2}$ "	104'-4 $\frac{7}{8}$ "	112'-5 $\frac{1}{4}$ "	155'-7 $\frac{1}{2}$ "	163'-7 $\frac{1}{8}$ "	171'-6 $\frac{3}{4}$ "
10	5°-43'-29"	29'-10 $\frac{3}{4}$ "	119'-8 $\frac{7}{16}$ "	129'-8 $\frac{1}{8}$ "	139'-7 $\frac{13}{16}$ "	120'-3 $\frac{5}{8}$ "	130'-3 $\frac{15}{16}$ "	140'-4 $\frac{1}{4}$ "	179'-5 $\frac{15}{16}$ "	189'-5 $\frac{5}{8}$ "	199'-5 $\frac{5}{16}$ "
15	3°-49'-06"	39'-11 $\frac{3}{4}$ "	179'-9 $\frac{9}{16}$ "	194'-9 $\frac{3}{8}$ "	209'-9 $\frac{3}{16}$ "	180'-2 $\frac{3}{8}$ "	195'-2 $\frac{9}{16}$ "	210'-2 $\frac{15}{16}$ "	259'-9 $\frac{1}{16}$ "	274'-8 $\frac{7}{8}$ "	289'-8 $\frac{11}{16}$ "
20	2°-51'-51"	59'-6 $\frac{1}{2}$ "	239'-10 $\frac{11}{16}$ "	259'-10 $\frac{1}{16}$ "	279'-9 $\frac{15}{16}$ "	240'-1 $\frac{13}{16}$ "	260'-2"	280'-2 $\frac{1}{8}$ "	358'-11 $\frac{1}{4}$ "	378'-11 $\frac{1}{16}$ "	398'-10 $\frac{15}{16}$ "

T MASSACHUSETTS BAY TRANSPORTATION AUTHORITY	RAILROAD OPERATIONS	DWG. NO. 2002
		Oct. 28., 1992 ISSUE DATE

STANDARD CROSSOVERS
GENERAL LAYOUT

John D. Pray ENGINEERING OFFICER *W. A. Hall* CHIEF ENGINEERING OFFICER

BILL OF MATERIAL FOR A NO. 8 TURNOUT

QUANTITY	DESCRIPTION	REFERENCE PLAN NO.
1*	PAIR 16'-6" SWITCH POINTS COMPLETE WITH REINFORCING BARS, CLIPS AND STOPS ATTACHED.	2104
2	HEEL BLOCK ASSEMBLIES, COMPLETE	2350
2*	39'-0" UNDERCUT STOCK RAILS	2104
1	INSULATED GAGE PLATE (NO. 1G)	2106
2	NO. 0 ADJUSTABLE BRACE SLIDE PLATES	2106
2	NO. 1A ADJUSTABLE BRACE SLIDE PLATES	2106
4	NO. 1 ADJUSTABLE BRACE SLIDE PLATES	2106
2	NO. 2 ADJUSTABLE BRACE SLIDE PLATES	2106
6	NO. 1-P SHOULDER SLIDE PLATES	2106
2	NO. 3 SHOULDER SLIDE PLATES	2106
2	NO. SH HEEL PLATES, 1-RH AND 1-LH	2106
2	SWITCH RAIL STOPS	2350
4	ADJUSTABLE ROCKER CLIPS FOR VERTICAL SWITCH RODS	2107
2	INSULATED VERTICAL SWITCH RODS (NO. 1 & 2)	2107
20	TURNOUT PLATES FOR USE BEHIND HEEL OF SWITCH (NO. 8-2 TO 8-11 X 2)	2340
12	RESILIENTLY FASTENED ADJUSTABLE RAIL BRACE	2352
1	NO. 8 RAILBOUND MANGANESE STEEL FROG, COMPLETE	2084
8	NO. P27 SELF ALIGNING SHOULDER TIE PLATE	2328
10	NO. P31 SELF ALIGNING SHOULDER TIE PLATE	2328
2	NO. P35 SELF ALIGNING SHOULDER TIE PLATE	2328
4	NO. PR27 SELF ALIGNING SHOULDER TIE PLATE	2328
2	NO. PR31 SELF ALIGNING SHOULDER TIE PLATE	2328



* THESE ITEMS SHALL BE SUPPLIED FOR R.H., L.H. OR EQUILATERAL TURNOUT, AS REQUIRED

QUANTITY	DESCRIPTION	REFERENCE PLAN NO.
2	10'-0" MANGANESE STEEL ONE PIECE GUARD RAILS	2300
2	BOLTED, POLY TYPE INSULATED JOINT ASSEMBLY	-
-	19'-6" BONDED INSULATED JOINT PLUG RAIL	1340
2	39'-0" LENGTHS OF FULLY HEAT TREATED RAIL	-
1 EA.	VARIOUS LENGTHS OF FULLY, HEAT TREATED RAIL AS FOLLOWS: 25'-0", 25'-0" 24'-5 1/2", 23'-5 1/2", 21'-3", 20'-0", 19'-6", 19'-6"	-
920	7" LOCK SPIKES	1216
100	5/8" x 6" A.R.E.A. SPIKES**	1210
360	RESILIENT FASTENER SPRING CLIPS - TYPE "E"	-
16	RESILIENT FASTENER SPRING CLIPS - TYPE MODIFIED "E"	-
124	STANDARD RESILIENT FASTENER TIE PLATES	1224
14	1:80 CANT TRANSITION TIE PLATES	2348
-	PAIRS OF MODIFIED JOINT BAR ASSEMBLIES (HEAD & TOE OF GAGE SIDE BARS REMOVED TO ALLOW SWITCH MOVEMENT AT JOINT NEAR HEEL OF SWITCH-NO. 20 ONLY)	2202
14	STANDARD JOINT BAR ASSEMBLIES	1322 OR 1320
56	STANDARD TRACK BOLTS WITH NUTS AND WASHERS	1332

** CUT SPIKES ARE FURNISHED BY THE INSTALLER
• WELD KITS (14) TO BE FURNISHED BY THE INSTALLER

NOTES:

- TURNOUTS SUPPLIED SHALL BE EITHER 115 OR 132 LB. RE AS SPECIFIED IN THE ORDER.
- TURNOUTS SHALL BE RESILIENTLY FASTENED THROUGHOUT, EXCEPT FROG TIE PLATES. GUARD RAILS AND LOCATIONS WHERE SPRING CLIPS CANNOT BE PHYSICALLY INSTALLED SUCH AS ON TURNOUT PLATES NEAR HEEL.
- FABRICATOR SHALL SUPPLY ALL MATERIAL REQUIRED FOR THE COMPLETE INSTALLATION OF THE TURNOUT EXCEPT SWITCH TIMBER UNLESS OTHERWISE SPECIFIED IN THE ORDER.
- FOR SWITCH TIMBER SCHEDULE, SEE PLAN 2082.

 MASSACHUSETTS BAY TRANSPORTATION AUTHORITY	RAILROAD OPERATIONS	DWG. NO. 2080
		JAN. 5, 1996 ISSUE DATE
NO. 8 TURNOUT BILL OF MATERIAL		
 SECTION CHIEF		

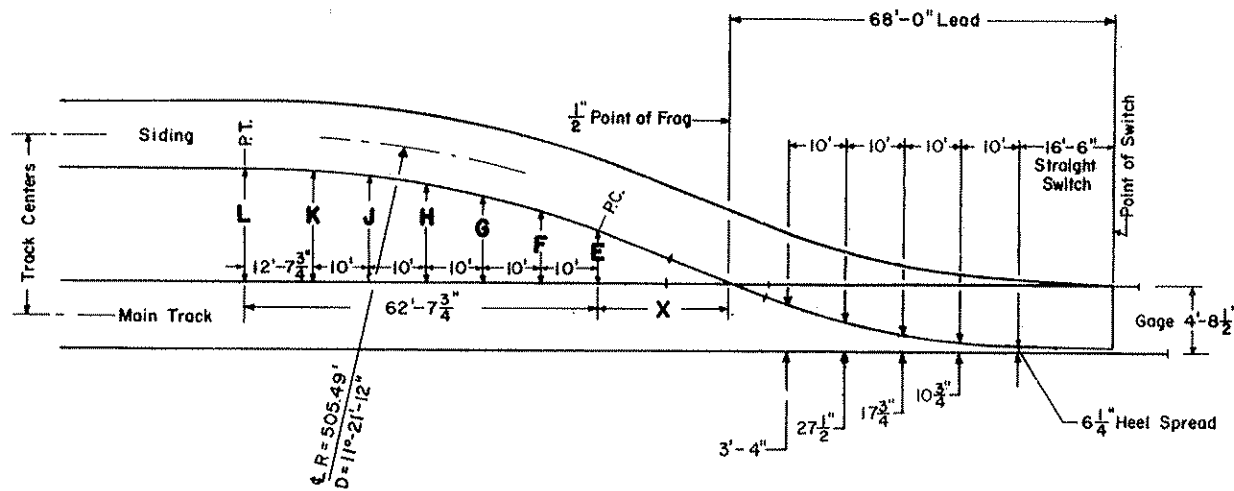

TURNOUT DATA

FROG - No. 8 Angle $7^{\circ}-09'-10''$

FROG DIMENSIONS

RAIL SECTION	FROG TYPE	LENGTH		
		TOE	HEEL	TOTAL
115, 132	RBM	7'-0"	11'-0"	18'-0"
115, 132	S.G.	2'-11"	6'-0"	8'-11"

SWITCH RAILS

Length ----- 16'-6"
 Type ----- Straight
 Switch Angle For Samson Switch Points ----- $1^{\circ}-48'-32''$
 Heel Block Angle ----- Same As Switch Angle
 Point of Switch to P.C. ----- $19'-4\frac{1}{2}''$

LEAD

Point of Switch to $\frac{1}{2}$ " Point of Frog ----- 68'-0"
 Radius ----- 446.162'
 Degree of Curve ----- $12^{\circ}-52'-08''$

CLOSURE RAIL DIMENSIONS

RAIL SECTION	FROG TYPE	LENGTH OF CLOSURE RAILS	
		CURVED	STRAIGHT
115, 132	RBM	$44'-8\frac{11}{16}''$	44'-6"
115, 132	S.G.	$48'-9\frac{11}{16}''$	48'-7"

OFFSETS BEHIND THE HEEL OF FROG

TRACK CENTERS	X	E	F	G	H	J	K	L
12'-2"	$27'-10\frac{3}{4}''$	$3'-6\frac{1}{2}''$	$4'-8\frac{3}{8}''$	$5'-7\frac{3}{4}''$	$6'-4\frac{3}{4}''$	$6'-11\frac{3}{8}''$	$7'-3\frac{5}{8}''$	$7'-5\frac{1}{2}''$
12'-4"	$29'-2\frac{1}{2}''$	$3'-8\frac{1}{2}''$	$4'-10\frac{3}{8}''$	$5'-9\frac{3}{4}''$	$6'-6\frac{3}{4}''$	$7'-1\frac{3}{8}''$	$7'-5\frac{5}{8}''$	$7'-7\frac{1}{2}''$
12'-6"	$30'-6\frac{1}{2}''$	$3'-10\frac{1}{2}''$	$5'-0\frac{3}{8}''$	$5'-11\frac{3}{4}''$	$6'-8\frac{3}{4}''$	$7'-3\frac{3}{8}''$	$7'-7\frac{5}{8}''$	$7'-9\frac{1}{2}''$
12'-8"	$31'-10\frac{1}{2}''$	$4'-0\frac{1}{2}''$	$5'-2\frac{3}{8}''$	$6'-1\frac{3}{4}''$	$6'-10\frac{5}{4}''$	$7'-5\frac{3}{8}''$	$7'-9\frac{5}{8}''$	$7'-11\frac{1}{2}''$
12'-10"	$33'-2\frac{3}{8}''$	$4'-2\frac{1}{2}''$	$5'-4\frac{3}{8}''$	$6'-3\frac{3}{4}''$	$7'-0\frac{3}{4}''$	$7'-7\frac{3}{8}''$	$7'-11\frac{5}{8}''$	$8'-1\frac{1}{2}''$
13'-0"	$34'-6\frac{3}{8}''$	$4'-4\frac{1}{2}''$	$5'-6\frac{3}{8}''$	$6'-5\frac{3}{4}''$	$7'-2\frac{5}{4}''$	$7'-9\frac{3}{8}''$	$8'-1\frac{5}{8}''$	$8'-3\frac{1}{2}''$
13'-2"	$35'-10\frac{1}{4}''$	$4'-6\frac{1}{2}''$	$5'-8\frac{3}{8}''$	$6'-7\frac{3}{4}''$	$7'-4\frac{5}{4}''$	$7'-11\frac{3}{8}''$	$8'-3\frac{5}{8}''$	$8'-5\frac{1}{2}''$
13'-4"	$37'-2\frac{1}{4}''$	$4'-8\frac{1}{2}''$	$5'-8\frac{3}{8}''$	$6'-9\frac{3}{4}''$	$7'-6\frac{5}{4}''$	$8'-1\frac{3}{8}''$	$8'-5\frac{5}{8}''$	$8'-7\frac{1}{2}''$
13'-6"	$38'-6\frac{1}{8}''$	$4'-10\frac{1}{2}''$	$5'-10\frac{3}{8}''$	$6'-11\frac{3}{4}''$	$7'-8\frac{5}{4}''$	$8'-3\frac{3}{8}''$	$8'-7\frac{5}{8}''$	$8'-9\frac{1}{2}''$

Values for track centers not shown may be determined by interpolation.

	MASSACHUSETTS BAY TRANSPORTATION AUTHORITY	RAILROAD OPERATIONS	DWG. NO. 2081
			Nov. 17, 1986 <small>ISSUE DATE</small>
OFFSETS FOR NO. 8 TURNOUT 115 OR 132 R.E. RAIL-UNDERCUT			 <small>ENGINEERING OFFICER</small>
			 <small>CHIEF ENGINEERING OFFICER</small>

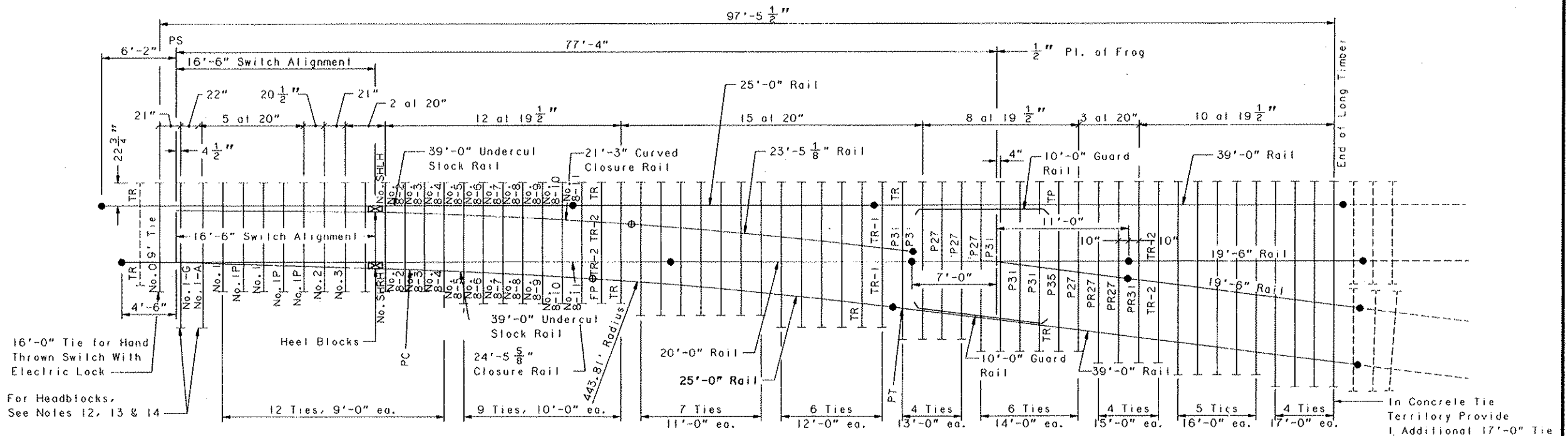

FROG TIE PLATES

- 8- P27 SAS (Self-Aligning Shoulder)
- 10 - P31 SAS
- 2 - P35 SAS
- 4 - PR27 SAS
- 2 - PR31 SAS

NOTES

- 1-Stock rails and switch points and all rails furnished to be fully heat treated.
- 2-Switch Points per A.R.E.A. Detail 5100 as shown on Plan 2104.
- 3-39' stock rails, to be undercut as per Plan 2104.
- 4-For switch details see Plan 2104.
- 5-Gage plate No. 1 - 6 as per Plan 2106.
- 6-Switch plates Nos. 0, 1, 1A, 1P and 1P as per Plan 2106.
- 7-Turnout plates, No. 2 thru No. 12, as per Plan 2340.
- 8-Vertical insulated switch rods and adjustable rocker clips, as per Plan 2107.
- 9-Heel block as per Plan 2350.
- 10-All rails to be drilled as shown on this plan, except that first hole is not to be drilled by the manufacturer. Installer to field drill first hole when necessary.
- 11-All tie plates to be resiliently fastened except guard rails.
- 12-Two 9"x10"x13' Headblocks needed with switch stand 3' high or less, 16' long with stands over 3'.
- 13-Three 9"x10"x16' Headblocks needed for hand thrown switch with electric lock.
- 14-Two 9"x10"x12' Headblocks needed for power operated switch.
- 15-See Plan 2080 for Bill of Material.
- 16-Rail lengths are computed to allow a 1/8" gap for temporarily bolting the field joints and 3/16" gap for insulated joints. When rails are welded in the field, they must be cut to provide gaps recommended by the weld kit manufacturer.
- 17-Transition Plates (TR) 1:80 Cont, as per Plan 2348.

LEGEND

- Indicates rails furnished by the manufacturer.
- - - Indicates rails furnished by the installer.
- ⊗ Indicates joints of heel of switch-not to be welded
- ⊕ Indicates insulated joints with 3/16" opening.
- Indicates joints to be field welded.

LONG TIMBERS REQUIRED

Quantity	Length
13*	9'-0"
9	10'-0"
7	11'-0"
6	12'-0"
4	13'-0"
6	14'-0"
4	15'-0"
5	16'-0"
4**	17'-0"
58	Total

*Headblocks not shown in table, see notes 12, 13 & 14.
 ** 5, 17'-0" ties in concrete tie territory

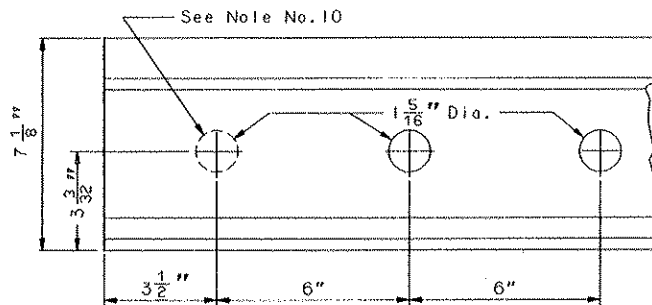

RAIL END DRILLING

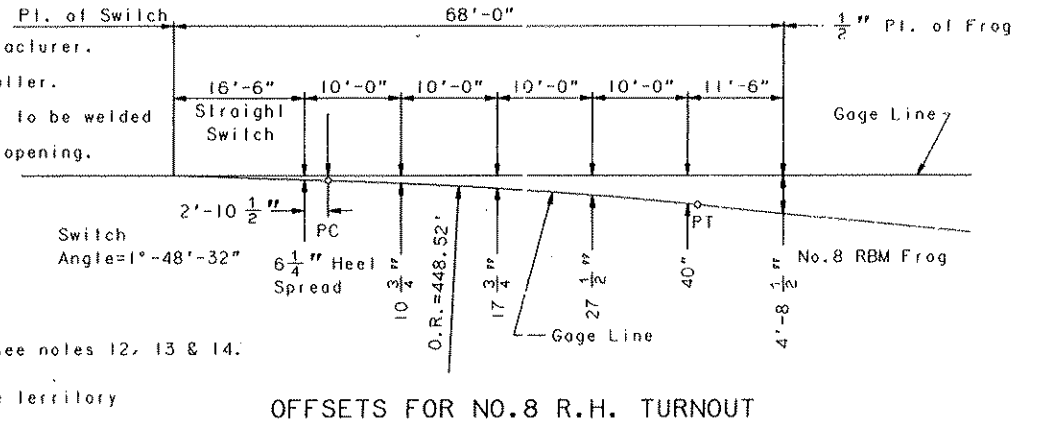

OFFSETS FOR NO. 8 R.H. TURNOUT

	MASSACHUSETTS BAY TRANSPORTATION AUTHORITY	RAILROAD OPERATIONS	DWG. NO. 2082 JAN. 5, 1996 ISSUE DATE
	NO. 8 WELDED TURNOUT TIE & RAIL LAYOUT		
			ISSUE NO. 3

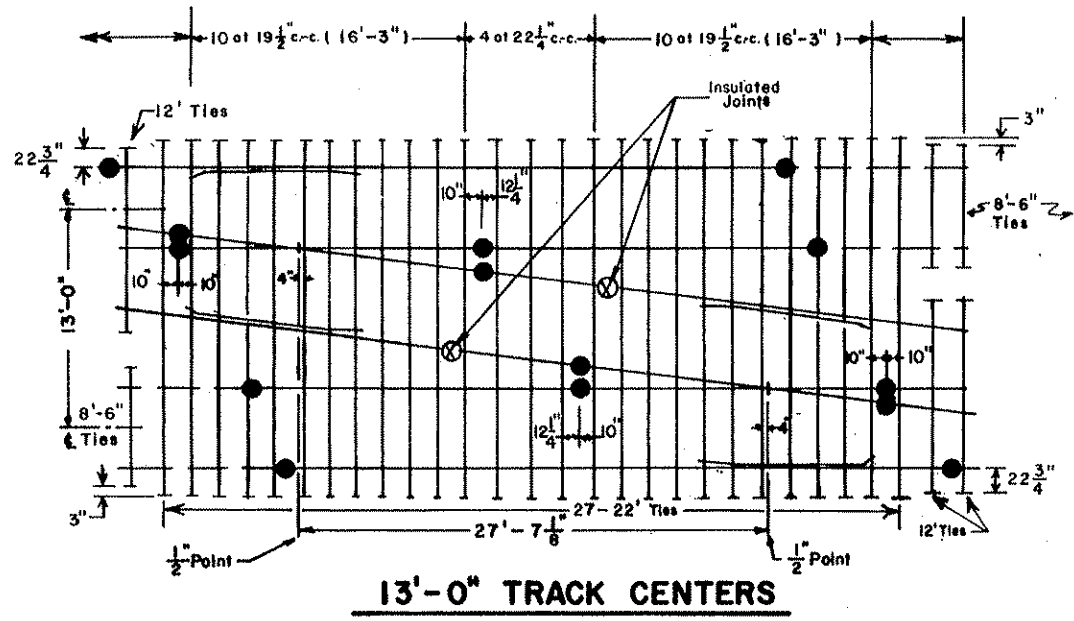

13'-0" TRACK CENTERS

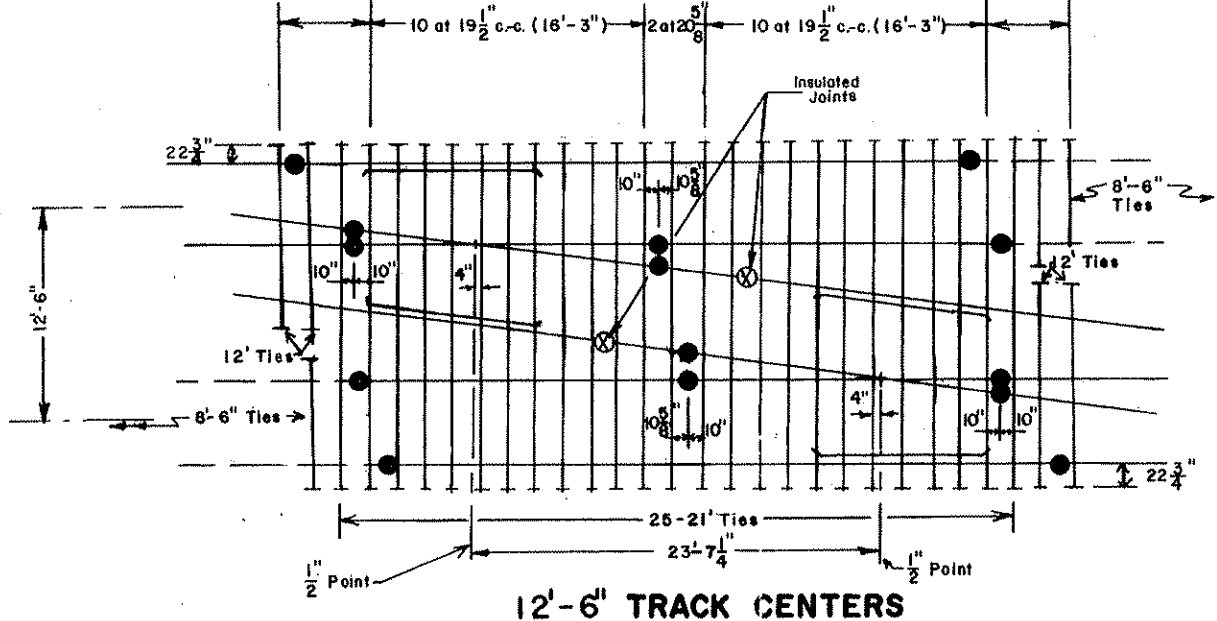

12'-6" TRACK CENTERS

For every 1" change in track centers, the horizontal distance between 1/2" frog points will change 8" (approx.)

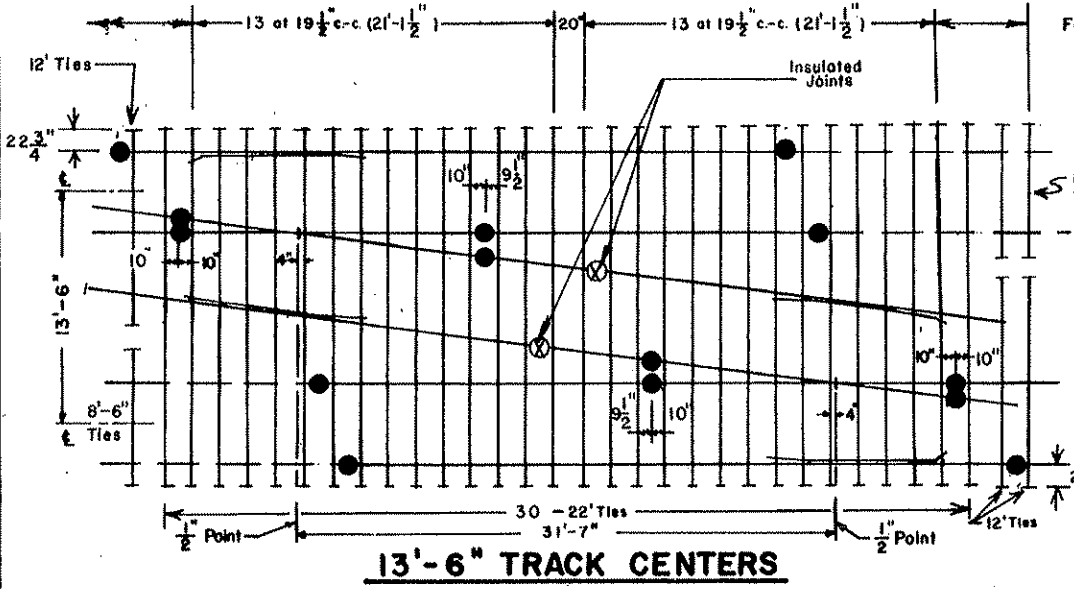

13'-6" TRACK CENTERS

SWITCH TIMBER FOR A CROSSOVER

TRACK CENTERS	TIMBER LENGTHS						
	9'-0"	10'-0"	11'-0"	12'-0"	13'-0"	21'-0"	22'-0"
12'-6"	26 *	18	14	12	—	25	—
13'-0"	26 *	18	14	12	—	—	27
13'-6"	26 *	18	14	12	—	—	30

FOR HEADBLOCKS, ADD THE FOLLOWING 9" x 10" TIMBERS:
 Handthrown Switch - 4 - 13'-0" with switchstand less than 3' high, 4-16'-0" w/3' +
 * Handthrown Switch with Electric Locking - 6 - 16'-0" and delete 2 - 9'-0" from Table.
 Power Operated Switch - 4 - 12'-0"

Frog Angle = 7°-09'-10"

NOTE: Timber layout shown is for exact track centers indicated. Other track centers require adjusting the timber schedule and timber spacing as required. All timber must extend a minimum of 18" from field side base of rail.

MASSACHUSETTS BAY TRANSPORTATION AUTHORITY	RAILROAD OPERATIONS	DWG. NO. 2083
		Oct. 28, 1992 ISSUE DATE

NO. 8 CROSSOVER TIE AND RAIL LAYOUT

John D. Ray ENGINEERING OFFICER *W. A. ...* CHIEF ENGINEERING OFFICER

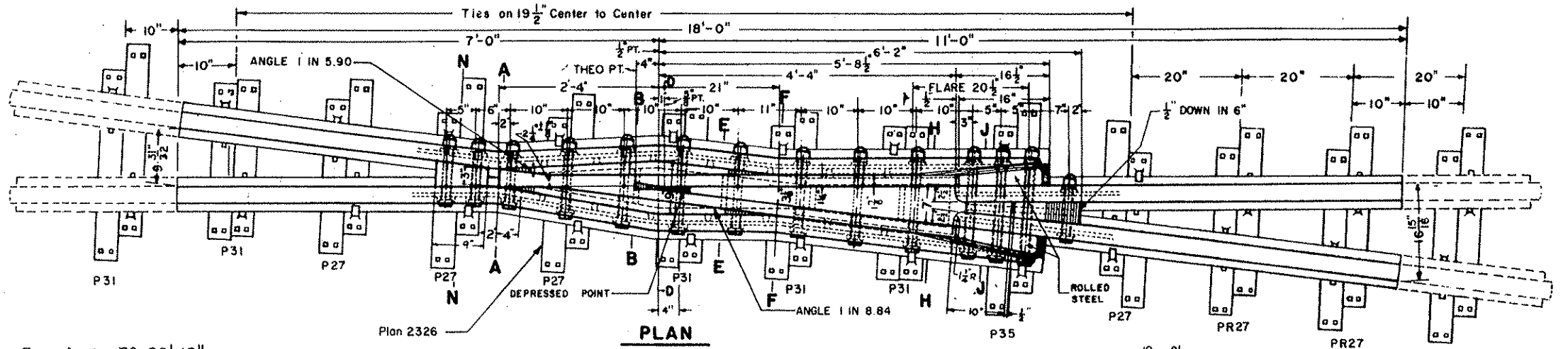

Frog Angle = 7°-09'-10"

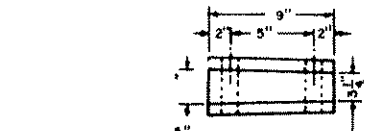

SPREADS SHOWN ARE 3/8" DOWN ON RAIL HEAD

TOE FILLER BLOCK

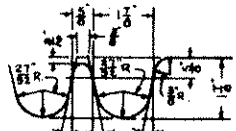

SECTION AT POINT

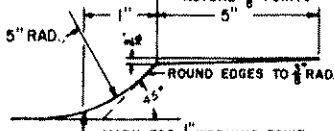

MARK FOR 1/2" WORKING POINT

ELEVATION OF POINT

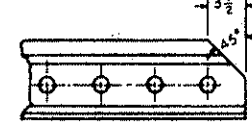

BEVELED END WING RAIL

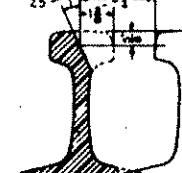

PLANING AT END OF WING RAIL

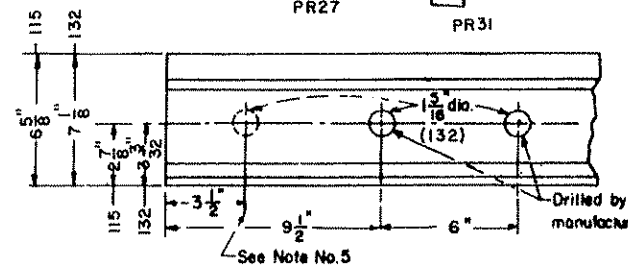

See Note No. 5

RAIL END DRILLING

FROG TIE PLATES REQ.

- 8 - P27
- 10 - P31
- 2 - P35
- 4 - PR27
- 2 - PR31

Note: For bolt lengths and quantities, see drawing No. 2502.

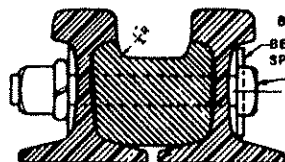

SECTION N-N

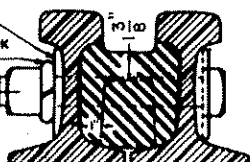

SECTION A-A

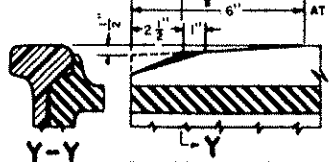

TYPICAL LONGITUDINAL SECTION AT TOE AND HEEL END OF MANGANESE

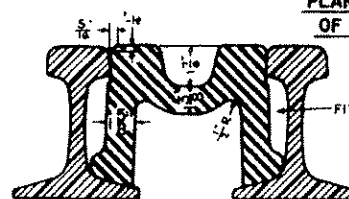

SECTION B-B

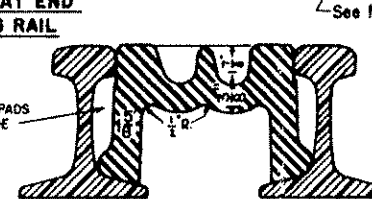

SECTION D-D

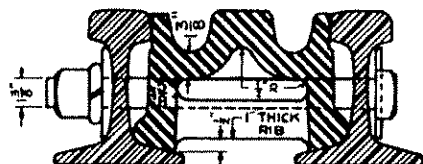

SECTION E-E

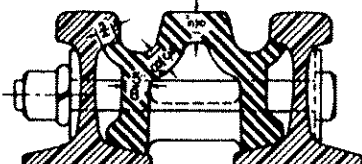

SECTION F-F

NOTES

- 1 - This plan is for use with A.R.E.A. recommended standards for 115 or 132 R.E. Rail
- 2 - Workmanship and materials, including beveling and hardening rail ends, shall be per current "A.R.E.A. Specifications" for heavy wall section frogs.
- 3 - Groove for bond wires shall extend from end of filler block at least to the centerline of second bolt hole.
- 4 - All bolts used in construction of frog, shall be dipped immediately before applying (so that all threads are thoroughly coated) in grease.
- 5 - When frog is to be used in bolted track, first bolt hole to be drilled in the field by installer as shown on this plan.
- 6 - Casting to be explosion hardened, with toe and heel arms to be fully heat treated rail.

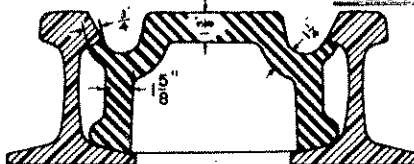

SECTION H-H

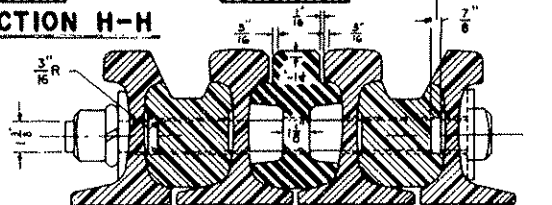

SECTION J-J

T	MASSACHUSETTS BAY TRANSPORTATION AUTHORITY	RAILROAD OPERATIONS	DWG. NO. 2084
			Jan. 5, 1996 ISSUE DATE
No. 8 RAILBOUND MANGANESE STEEL FROG			
FOR 115 LB. OR 132 LB. R.E. RAIL			
<i>John D. Ray</i>			
SECTION CHIEF			

BILL OF MATERIAL FOR A NO. 10 TURNOUT

Quantity	Description	Reference Plan No.
* 1	Pair of 16'-6" Switch Points, complete with reinforcing bars, clips and stops attached	2104
2	Heel Block Assemblies, complete	2350
* 2	39'-0" Undercut Stock Rails	2104
1	Insulated Gage Plates (No's. 1-6)	2106
2	No. 0 Adjustable Brace Slide Plates	2106
2	No. 1A Adjustable Brace Slide Plates	2106
4	No. 1 Adjustable Brace Slide Plates	2106
2	No. 2 Adjustable Brace Slide Plates	2106
6	No. 1-P Shoulder Slide Plates	2106
2	No. 3 Shoulder Slide Plates	2106
2	No. SH Heel Plates, 1-RH and 1-LH	2106
2	Switch Rail Stops	2350
4	Adjustable Rocker Clips for Vertical Switch Rods	2107
2	Insulated Vertical Switch Rods (No. 1 & 2)	2107
22	Turnout Plates for use behind heel of switch (No. 10-2 to 10-12 x 2)	2340
12	Resiliently Fastened Adjustable Rail Brace	2352
1	No. 10 Railbound Manganese Steel Frog, Complete	2105
4	FT20 Hook Twin Tie Plates	2326
6	FT23 " " " "	"
10	FT27 " " " "	"
2	FT29 " " " "	"
-	FT23 Modified Hook Twin Tie Plates	"
2	FT27 " " " " "	"
2	FT29 " " " " "	"
-	FT33 " " " " "	"
-	FTR27 Hook Twin Tie Plates	"
2	FTR29 " " " "	"
-	FTR31 " " " "	"
-	FTR33 " " " "	"
-	FTR27 Modified Hook Twin Tie Plates	"
-	FTR29 " " " " "	"
2	FTR31 " " " " "	"

* These items shall be supplied for R.H., L.H. or Equilateral Turnout as required.

Quantity	Description	Reference Plan No.
2	FTR33 Modified Hook Twin Tie Plates	2326
2	13'-3" Manganese Steel One Piece Guard Rails	2302
2	Bolted, Poly Type Insulated Joint Assembly	-
-	19'-6" Bonded Insulated Joint Plug Rail	1340
2	39'-0" Lengths of Fully Heat Treated Rail	-
1 ea.	Various Lengths of Fully Heat Treated Rail, as follows: 23'-6", 23'-6", 16'-3 1/8", 26'-0", 25'-4 3/8", 23'-0", 21'-4", 33'-0", 13'-11", 19'-6"	-
1065	7" Lock Spikes	1216
100	5" x 8" AREA Spikes **	1210
450	Resilient Fastener Spring Clips - Type "E"	-
16	Resilient Fastener Spring Clips - Type Modified "E"	-
175	Standard Resilient Fastener Tie Plates	1224
-	Pairs of Modified Joint Bar Assemblies (Head & Toe of Gage Side Bars Removed to Allow Switch Movement at Joint near Heel of Switch - No. 20 only)	2202
16	Standard Joint Bar Assemblies	1322 or 1320
64	Standard Track Bolts with Nuts and Washers	1332

** Cut Spikes are furnished by the installer.

* Weld Kits (16) to be furnished by the installer.

Notes:

1. Turnouts supplied shall be either 115 or 132 LB. RE as specified in the order.
2. Turnouts shall be resiliently fastened throughout, except Frog Tie Plates, Guard Rails and locations where Spring Clips cannot be physically installed such as on turnout plates near heel.
3. Fabricator shall supply all material required for the complete installation of the turnout except switch timber unless otherwise specified in the order.
4. For Switch Timber Schedule, see Plan 2102

T	MASSACHUSETTS BAY TRANSPORTATION AUTHORITY	RAILROAD OPERATIONS	DWG. NO. 2100
			Oct. 28, 1992 ② ISSUE DATE ISSUE NO.
NO. 10 TURNOUT BILL OF MATERIAL			
<i>John D. Ray</i> ENGINEERING OFFICER		<i>W. A. Z. Gould</i> CHIEF ENGINEERING OFFICER	

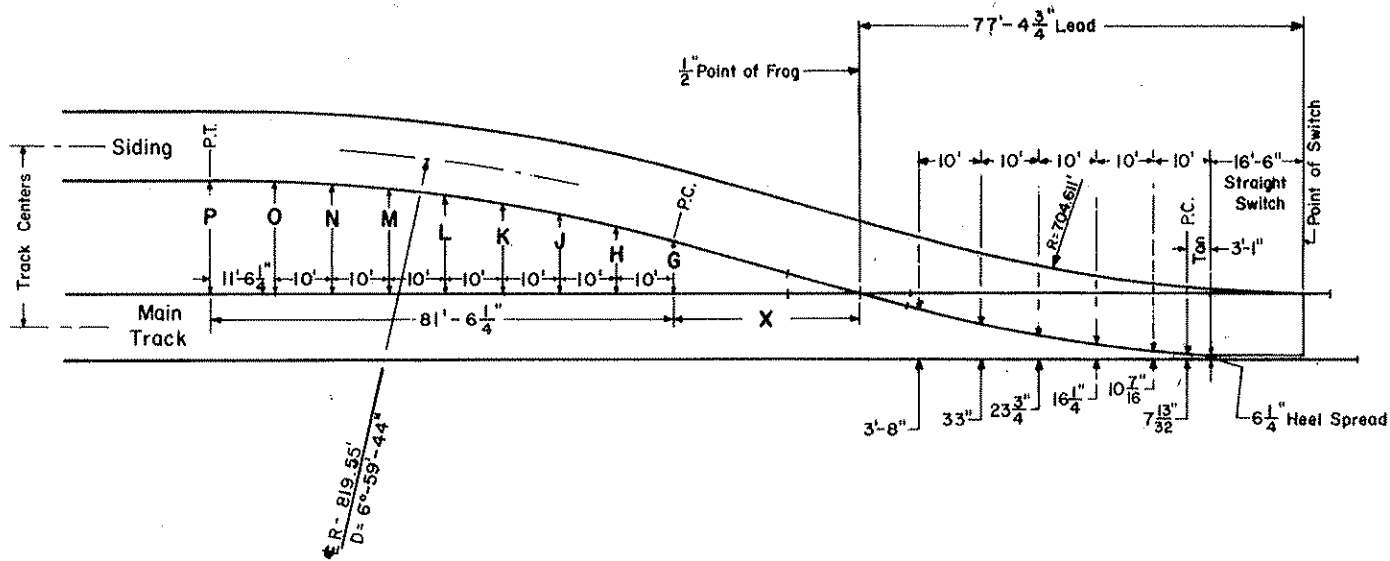

TURNOUT DATA

FROG - No. 10 Angle 5°-43'-29"

FROG DIMENSIONS

RAIL SECTION	FROG TYPE	LENGTH		
		TOE	HEEL	TOTAL
115, 132	RBM	9'-6"	13'-6"	23'-0"
115, 132	S.G.	3'-9"	7'-7 $\frac{1}{2}$ "	11'-4 $\frac{1}{2}$ "

SWITCH RAILS

Length ----- 16'-6"
 Type ----- Straight
 Switch Angle For Samson Switch Points ----- 1°-48'-32"
 Heel Block Angle ----- Same As Switch Angle
 Point of Switch to P.C. ----- 19'-7"

LEAD

Point of Switch to $\frac{1}{2}$ Point of Frog ----- 77'-4 $\frac{3}{4}$ "
 Degree of Curve ----- 8°-06'-40" *4766'*
 Radius ----- 706.965'

CLOSURE RAIL DIMENSIONS

RAIL SECTION	FROG TYPE	LENGTH OF CLOSURE RAILS	
		CURVED	STRAIGHT
115, 132	RBM	5'-6 $\frac{11}{16}$ "	5'-4 $\frac{3}{4}$ "
115, 132	S.G.	57'-3 $\frac{11}{16}$ "	57'-1 $\frac{3}{4}$ "

OFFSETS BEHIND THE HEEL OF FROG

TRACK CENTERS	X	G	H	J	K	L	M	N	O	P
12'-2"	33'-3 $\frac{7}{8}$ "	3'-4 $\frac{5}{8}$ "	4'-3 $\frac{7}{8}$ "	5'-1 $\frac{5}{8}$ "	5'-10"	6'-4 $\frac{7}{8}$ "	6'-10 $\frac{1}{4}$ "	7'-2 $\frac{1}{8}$ "	7'-4 $\frac{1}{2}$ "	7'-5 $\frac{1}{2}$ "
12'-4"	34'-11 $\frac{7}{8}$ "	3'-6 $\frac{5}{8}$ "	4'-5 $\frac{7}{8}$ "	5'-3 $\frac{5}{8}$ "	6'-0"	6'-6 $\frac{7}{8}$ "	7'-0 $\frac{1}{4}$ "	7'-4 $\frac{1}{8}$ "	7'-6 $\frac{1}{2}$ "	7'-7 $\frac{1}{2}$ "
12'-6"	36'-7 $\frac{3}{4}$ "	3'-8 $\frac{5}{8}$ "	4'-7 $\frac{7}{8}$ "	5'-5 $\frac{5}{8}$ "	6'-2"	6'-8 $\frac{7}{8}$ "	7'-2 $\frac{1}{4}$ "	7'-6 $\frac{1}{8}$ "	7'-8 $\frac{1}{2}$ "	7'-9 $\frac{1}{2}$ "
12'-8"	38'-3 $\frac{3}{4}$ "	3'-10 $\frac{5}{8}$ "	4'-9 $\frac{7}{8}$ "	5'-7 $\frac{5}{8}$ "	6'-4"	6'-10 $\frac{7}{8}$ "	7'-4 $\frac{1}{4}$ "	7'-8 $\frac{1}{8}$ "	7'-10 $\frac{1}{2}$ "	7'-11 $\frac{1}{2}$ "
12'-10"	39'-11 $\frac{3}{4}$ "	4'-0 $\frac{5}{8}$ "	4'-11 $\frac{7}{8}$ "	5'-9 $\frac{5}{8}$ "	6'-6"	7'-0 $\frac{7}{8}$ "	7'-6 $\frac{1}{4}$ "	7'-10 $\frac{1}{8}$ "	8'-0 $\frac{1}{2}$ "	8'-1 $\frac{1}{2}$ "
13'-0"	41'-7 $\frac{5}{8}$ "	4'-2 $\frac{5}{8}$ "	5'-1 $\frac{7}{8}$ "	5'-11 $\frac{5}{8}$ "	6'-8"	7'-2 $\frac{7}{8}$ "	7'-8 $\frac{1}{4}$ "	8'-0 $\frac{1}{8}$ "	8'-2 $\frac{1}{2}$ "	8'-3 $\frac{1}{2}$ "
13'-2"	43'-3 $\frac{1}{2}$ "	4'-4 $\frac{5}{8}$ "	5'-3 $\frac{7}{8}$ "	6'-1 $\frac{5}{8}$ "	6'-10"	7'-4 $\frac{7}{8}$ "	7'-10 $\frac{1}{4}$ "	8'-2 $\frac{1}{8}$ "	8'-4 $\frac{1}{2}$ "	8'-6 $\frac{1}{2}$ "
13'-4"	44'-11 $\frac{5}{8}$ "	4'-6 $\frac{5}{8}$ "	5'-5 $\frac{7}{8}$ "	6'-3 $\frac{5}{8}$ "	7'-0"	7'-6 $\frac{7}{8}$ "	8'-0 $\frac{1}{4}$ "	8'-4 $\frac{1}{8}$ "	8'-6 $\frac{1}{2}$ "	8'-7 $\frac{1}{2}$ "
13'-6"	46'-7 $\frac{1}{2}$ "	4'-8 $\frac{5}{8}$ "	5'-7 $\frac{7}{8}$ "	6'-5 $\frac{5}{8}$ "	7'-2"	7'-8 $\frac{7}{8}$ "	8'-2 $\frac{1}{4}$ "	8'-6 $\frac{1}{8}$ "	8'-8 $\frac{1}{2}$ "	8'-9 $\frac{1}{2}$ "

Values for track centers not shown may be determined by interpolation

	RAILROAD OPERATIONS	DWG. NO. 2101
		Nov. 17, 1986 <small>ISSUE DATE</small>

OFFSETS FOR NO. 10 TURNOUT

115 OR 132 R.E. RAIL-UNDERCUT

ENGINEERING OFFICER

CHIEF ENGINEERING OFFICER

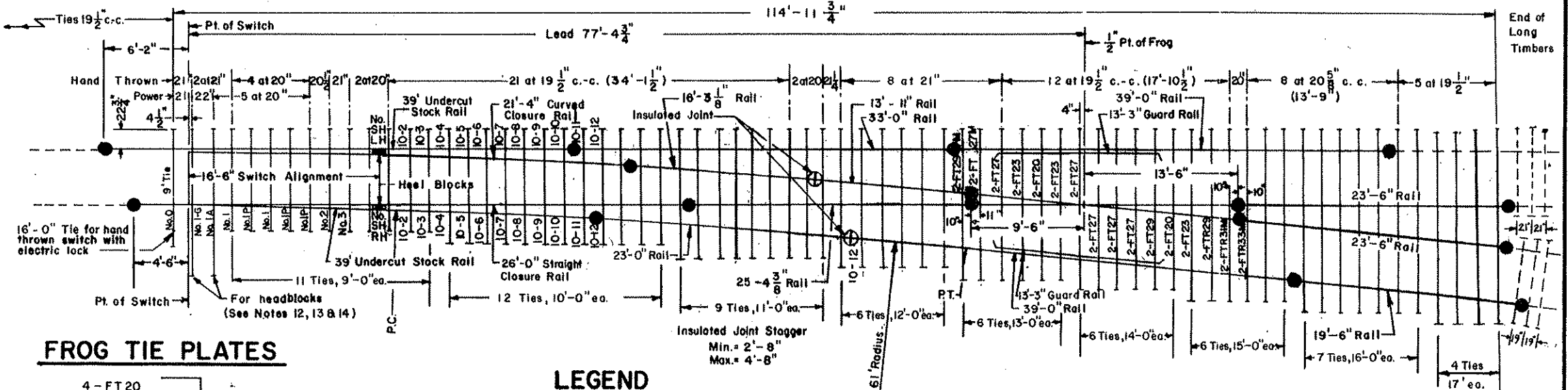

FROG TIE PLATES

- 4 - FT 20
- 6 - FT 23
- 10 - FT 27
- 2 - FT 27 Modified
- 2 - FT 29
- 2 - FT 29 Modified
- 2 - FTR 29
- 2 - FTR 31 Modified
- 2 - FTR 33 Modified

Plan 2326

NOTES

- 1 - Stock rails and switch points and all rails furnished to be fully heat treated.
- 2 - Switch points per A.R.E.A. detail 5100 as shown on plan 2104.
- 3 - 39' stock rails, to be undercut as per Plan 2104.
- 4 - For switch details see Plan 2104.
- 5 - Gage plate No. 1-G as per Plan 2106.
- 6 - Switch plates Nos. O, 1, 1A and 1P as per Plan 2106.
- 7 - Turnout plates, No. 2 thru No. 12, as per Plan 2340.
- 8 - Vertical insulated switch rods and adjustable rocker clips, generally as per Plan 2107.
- 9 - Heel block as per Plan 2350.
- 10 - All rails, including switch rails, to be drilled as shown on this plan, except that first hole is not to be drilled by the manufacturer. Forces designated by the Authority to field drill first hole when necessary.
- 11 - All tie plates to be resiliently fastened except frog tie plates and guard rails.
- 12 - Two 9" x 10" x 13' Headblocks needed with switch stand 3' high or less, 16' long with stands over 3'.
- 13 - Three 9" x 10" x 16' Headblocks needed for hand thrown switch with electric lock.
- 14 - Two 9" x 10" x 12' Headblocks needed for power operated switch.
- 15 - See Plan 2100 for Bill of Material.
- 16 - Use bolted, poly type insulated joints except when revenue passenger service operates over joints. In that case, use bonded insulated joint plug rolls and modify rail lengths accordingly.
- 17 - Rail lengths are computed to allow a 1/8" gap for temporarily bolting of the field welded joints and 3/16" gap for insulated joints. When rails are welded in the field, they must be cut to provide gaps recommended by the weld kit manufacturer.

LEGEND

- Indicates rolls furnished by the manufacturer.
- - - Indicates rolls furnished by the installer.
- ⊕ Indicates joints at heel of switch - not to be welded.
- ⊕ Indicates insulated joints with 3/8" opening. (Bolted, Poly Type) See Note 16.
- Indicates joints to be field welded.

LONG TIMBERS REQUIRED

QUANTITY	LENGTH
12 *	9'-0"
12	10'-0"
9	11'-0"
6	12'-0"
6	13'-0"
6	14'-0"
6	15'-0"
7	16'-0"
4 **	17'-0"
68 †	16' 1 1/2"

* 11 with electric lock
 ** 5-17'-0" ties in concrete tie territory

† 67 w. electric lock

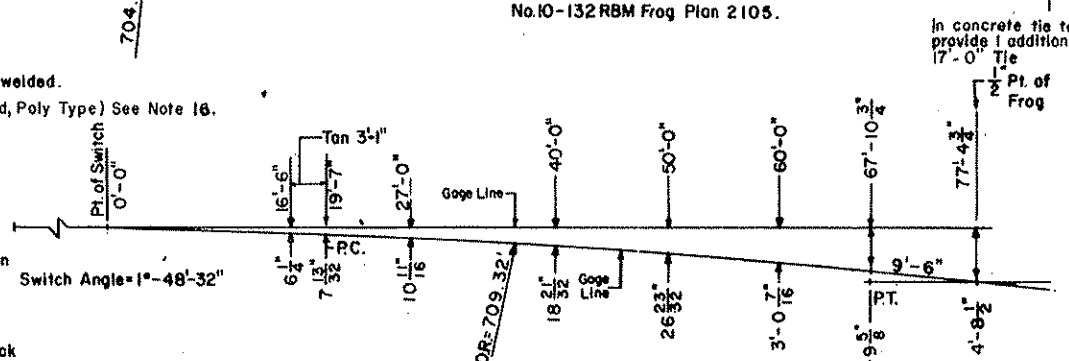

OFFSETS FOR NO. 10 R.H. TURNOUT

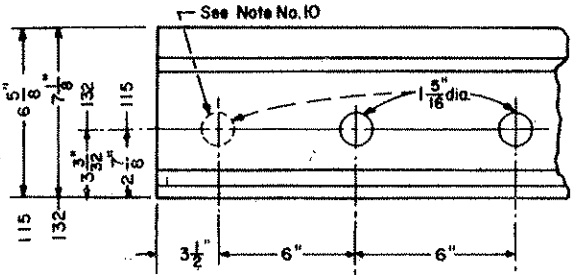

RAIL END DRILLING

	MASSACHUSETTS BAY TRANSPORTATION AUTHORITY	RAILROAD OPERATIONS	DWG. NO. 2102 Oct. 28, 1992 ISSUE DATE
	<p style="text-align: center;">NO. 10 WELDED TURNOUT TIE AND RAIL LAYOUT</p>		ISSUE NO. 2
John D. Ray ENGINEERING OFFICER		W. A. Z. [Signature] CHIEF ENGINEERING OFFICER	

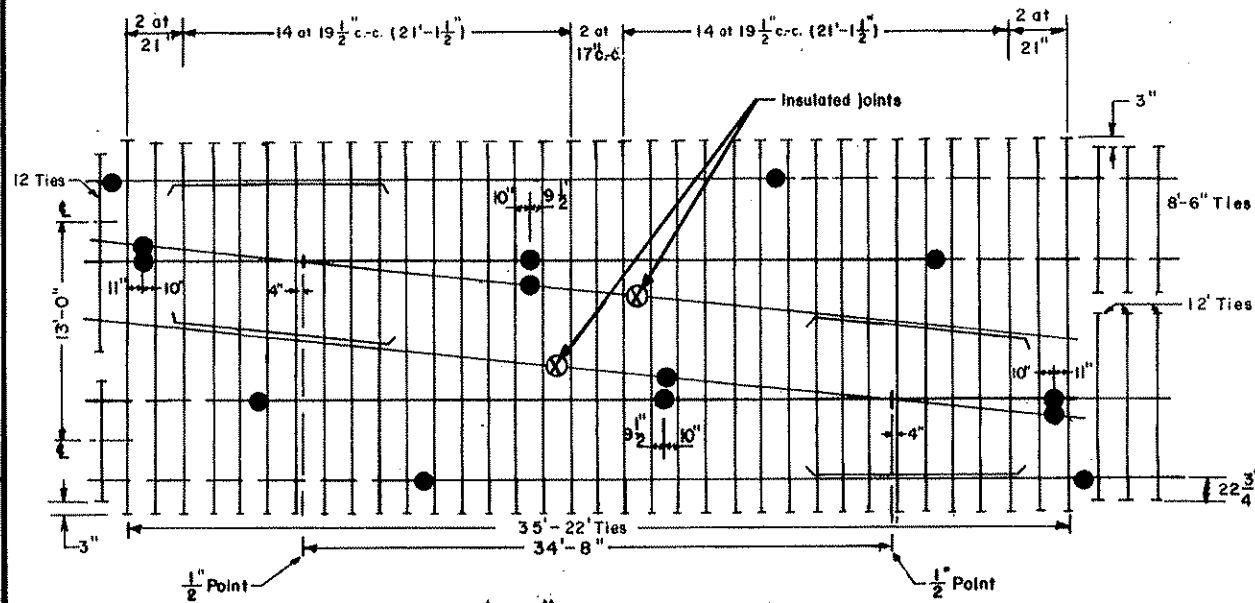

13'-0" TRACK CENTERS

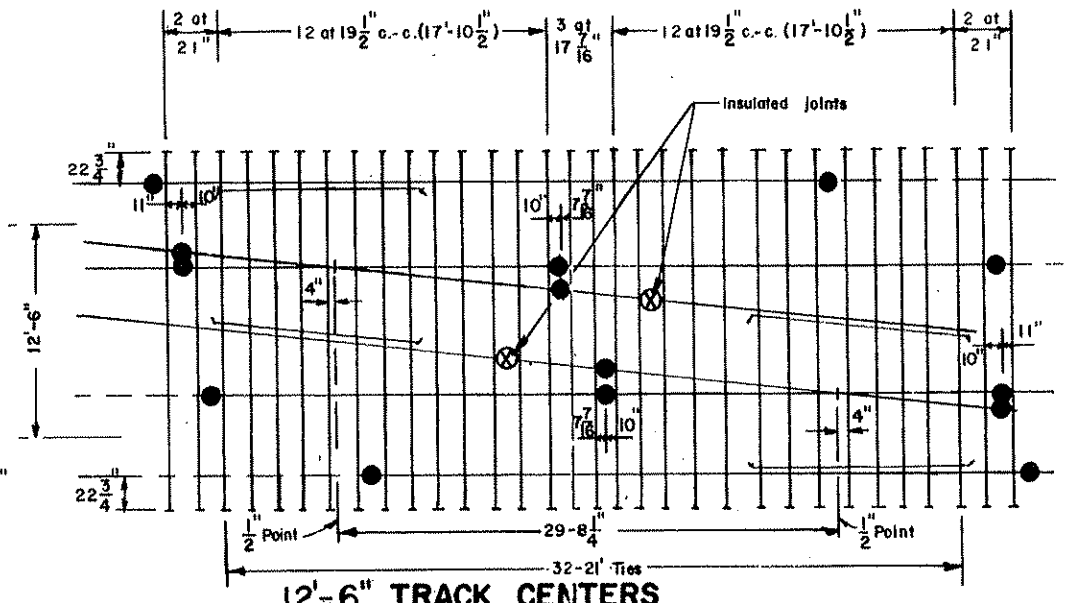

12'-6" TRACK CENTERS

For every 1" change in track centers, the horizontal distance between 1/2" frog points will change 10" (approx.)

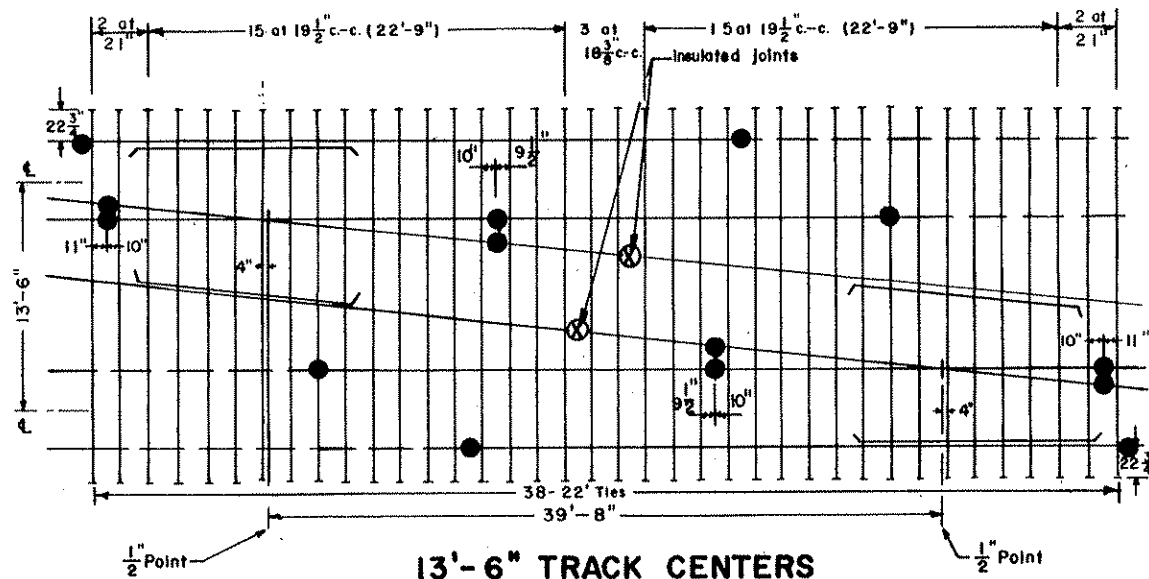

13'-6" TRACK CENTERS

Frog Angle = 5°-43'-29"

SWITCH TIMBER FOR A CROSSOVER

TRACK CENTERS	TIMBER LENGTHS						
	9'-0"	10'-0"	11'-0"	12'-0"	13'-0"	21'-0"	22'-0"
12'-6"	24	24	18	12	—	32	—
13'-0"	24	24	18	12	—	—	35
13'-6"	24	24	18	12	—	—	38

FOR HEADBLOCKS, ADD THE FOLLOWING 9" x 10" TIMBERS:

- Handthrown Switch - 4 - 13'-0" with switchstand less than 3' high, 16'-0" w/ 3' stand.
- *Handthrown Switch with Electric Locking - 6 - 16'-0" and delete 2-9'-0" from Table
- Power Operated Switch - 4 - 12'-0"

NOTE: Timber layout shown is for exact track centers indicated. Other track centers require adjusting the timber schedule and timber spacing as required.

	MASSACHUSETTS BAY TRANSPORTATION AUTHORITY	RAILROAD OPERATIONS	DWG. NO. 2103
			Oct. 28, 1992 <small>ISSUE DATE</small>
NO. 10 CROSS OVER TIE AND RAIL LAYOUT			
 <small>ENGINEERING OFFICER</small>		 <small>CHIEF ENGINEERING OFFICER</small>	

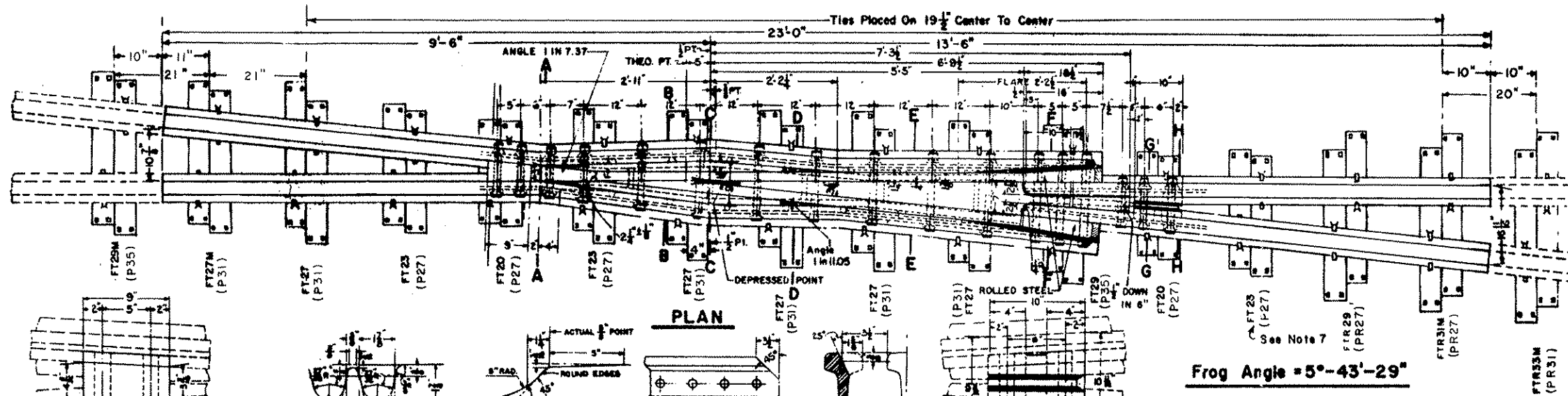

Frog Angle = 5°-43'-29"

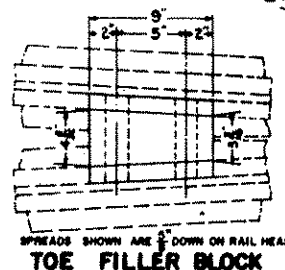

TOE FILLER BLOCK

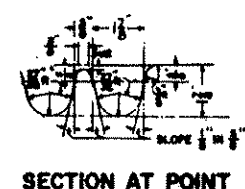

SECTION AT POINT

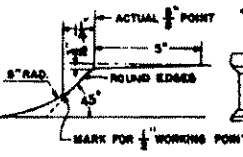

ELEVATION OF POINT

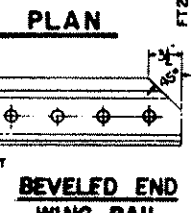

BEVELED END WING RAIL

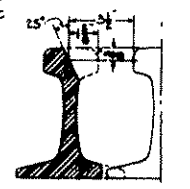

PLANING AT END OF WING RAIL

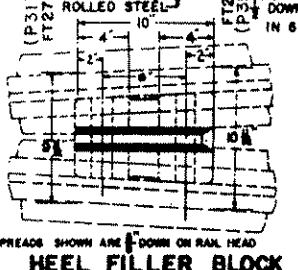

HEEL FILLER BLOCK

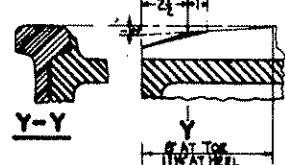

Y-Y

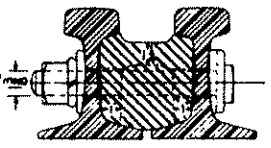

SECTION A-A

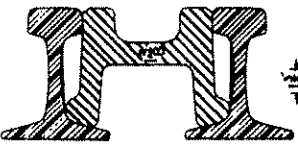

SECTION B-B

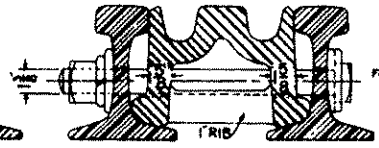

SECTION D-D

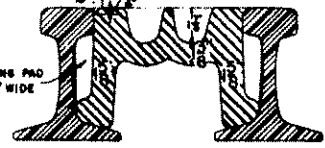

SECTION C-C

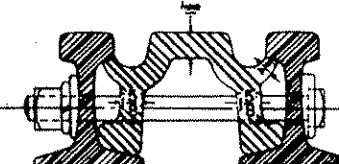

SECTION E-E

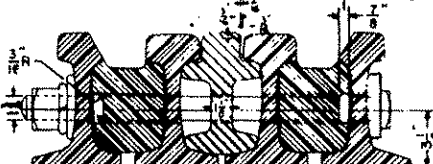

SECTION F-F

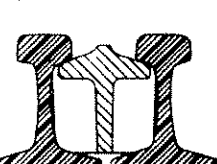

SECTION G-G

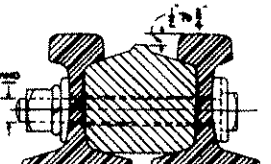

SECTION H-H

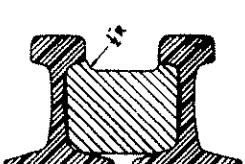

SECTION J-J

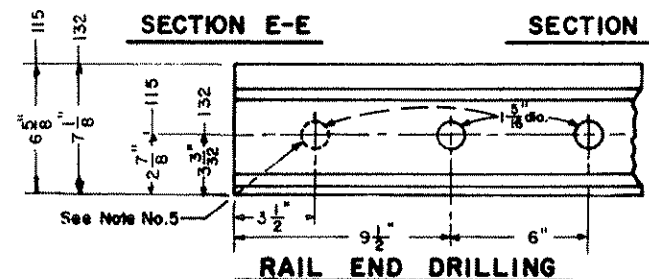

RAIL END DRILLING

- 10-P27 SAS(Self Aligning Shoulder)
- 12-P31 SAS Plan 2328
- 4-P35 SAS
- 4-PR27 SAS
- 2-PR31 SAS

Unless otherwise specified, furnish SAS Plates rather than FT Plates.

- 4 - FT 20
- 6 - FT 23
- 10 - FT 27
- 2 - FT 27 Modified
- 2 - FT 29
- 2 - FT 29 Modified
- 2 - FTR 29
- 2 - FTR 31 Modified
- 2 - FTR 33 Modified

Plan 2326

FROG TIE PLATES REQUIRED

NOTES

- 1 - This plan is for use with A.R.E.A. recommended standards for 115 and 132 lb RE Rail, Heavy Wall Section.
- 2 - Workmanship and materials including beveling shall be per current A.R.E.A. "Specifications".
- 3 - Groove for band wires shall extend from end of filler block at least to the center line of second bolt hole.
- 4 - All bolts used in construction of frog, shall be dipped immediately before applying (so that all threads are thoroughly coated) in grease.
- 5 - When frog is to be used in bolted track, the first bolt hole to be drilled in the field by the installer.
- 6 - Casting to be explosion hardened, with toe and heel arms to be fully heat treated rails.
- 7 - Both FT plates and SAS Plates (in parenthesis) shown. Furnish SAS Plates unless otherwise specified.

T	MASSACHUSETTS BAY TRANSPORTATION AUTHORITY	RAILROAD OPERATIONS	DWG. NO. 2105 Jan. 5, 1996 ISSUE DATE	(3) ISSUE NO.
	No. 10 RAILBOUND MANGANESE STEEL FROG FOR 115 LB. OR 132 LB. R.E. RAIL			
SECTION CHIEF				

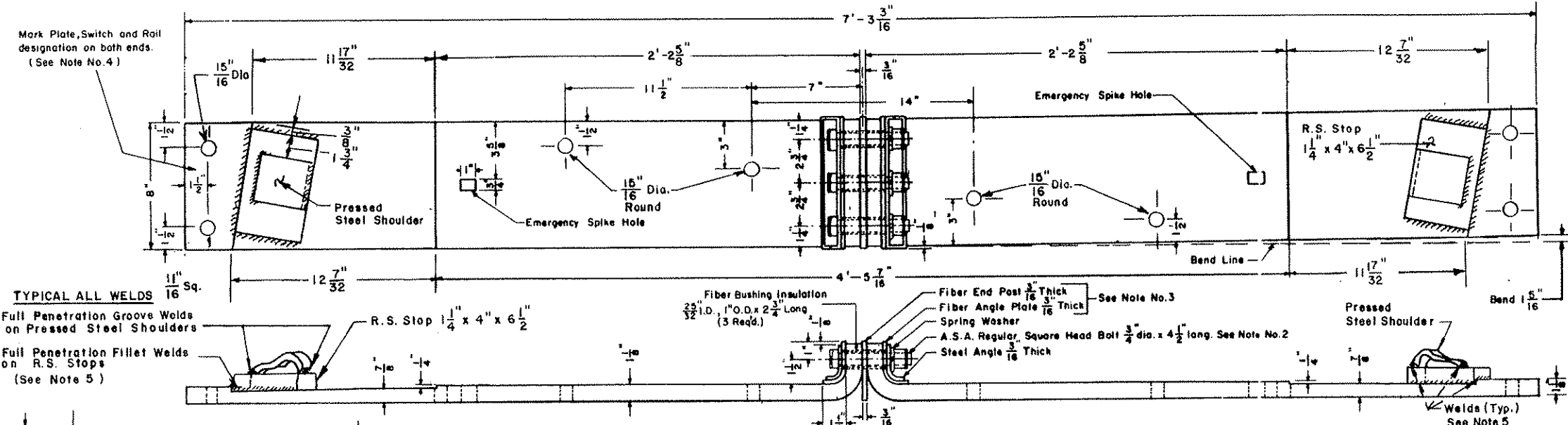

TYPICAL ALL WELDS
 Full Penetration Groove Welds on Pressed Steel Shoulders
 Full Penetration Fillet Welds on R.S. Stops
 (See Note 5)

NO. 1-G INSULATED GAGE PLATE

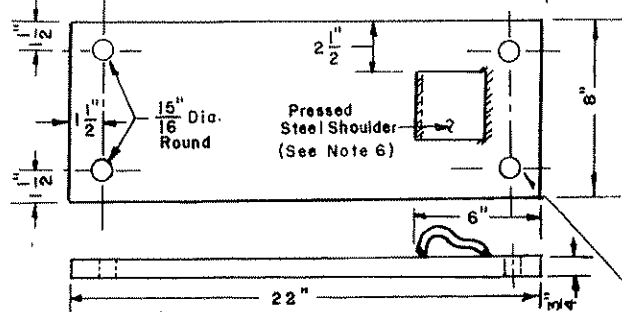

NO. 3 SHOULDER SLIDE PLATE

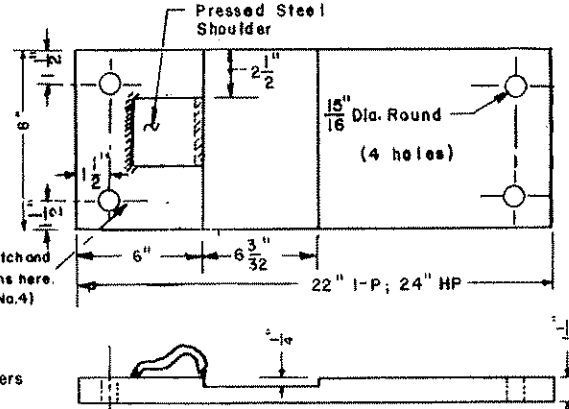

NO. 1-P & HP SHOULDER SLIDE PLATE

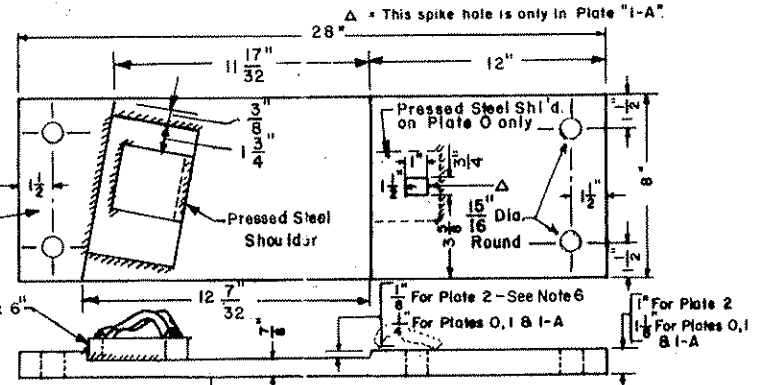

NO. 0, NO. 1, NO. 1-A & NO. 2 ADJUSTABLE BRACE SLIDE PLATES

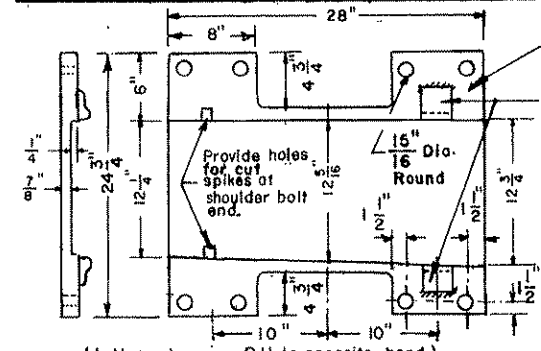

NO. SH (R.H. & L.H.) HEEL PLATES

NOTES

- 1 - Switch Plates shall conform to current A.R.E.A. Specifications for Low-Carbon Steel-Tie Plates, with copper.
- 2 - All gage plate bolts shall have A.S.A. Regular square heads and A.S.A. Heavy square nuts. All bolts shall be carbon-steel with medium-carbon steel nuts and conform to current A.R.E.A. "Specifications for Heat-Treated Carbon-Steel Track Bolts and Carbon Steel Nuts."
- 3 - All fiber parts shall conform to current A.A.R. Signal Section Manual, Part 5B, Specification No. 13 for "Hard Fiber" and A.A.R. Signal Section Manual, Part No. 17B covering "Requisites for Fabricated Fiber Parts for Track Insulation."
- 4 - Each plate shall be marked by deeply cut characters, not less than one half inch high, in the position as indicated on this plan, with the plate, switch and rail designations. Example 1-P, 16-6, 132
- 5 - Welds shall be made so they do not interfere with the installation of resilient fasteners, rail braces and rail.
- 6 - Modify contour of pressed steel shoulders or, use shims on plates 2 and 3 to maintain uniform toe pressure from the resilient fasteners.

T	MASSACHUSETTS BAY TRANSPORTATION AUTHORITY	RAILROAD OPERATIONS	DWG. NO. 2106
			Oct. 28, 1992 ISSUE DATE
SWITCH PLATES and GAGE PLATES			
FOR 16'-6" SWITCH-132 LB. RAIL			
<i>John D. Roy</i> ENGINEERING OFFICER		<i>W. A. ...</i> CHIEF ENGINEERING OFFICER	

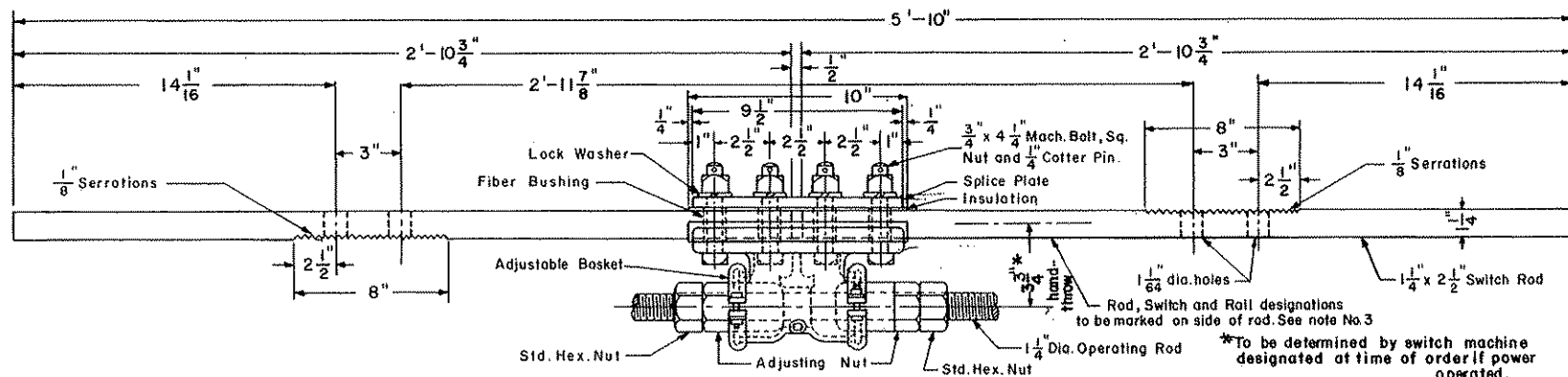

INSULATED SWITCH ROD NO. 1 WITH ADJUSTABLE BASKET

ROD NO.	X	B
2	3'-0 11/32"	4 53/64"
3*	3'-2 1/8"	3 15/16"

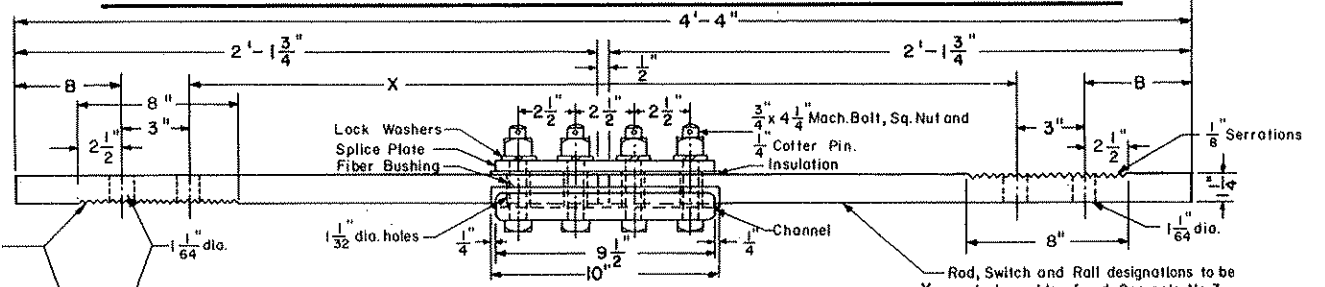

INSULATED SWITCH RODS-NOS. 2 & 3

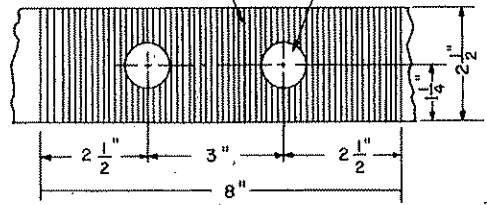

ELEVATION - SWITCH RODS

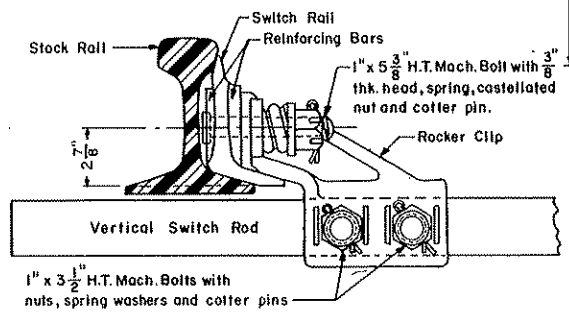

ASSEMBLED ROCKER CLIP

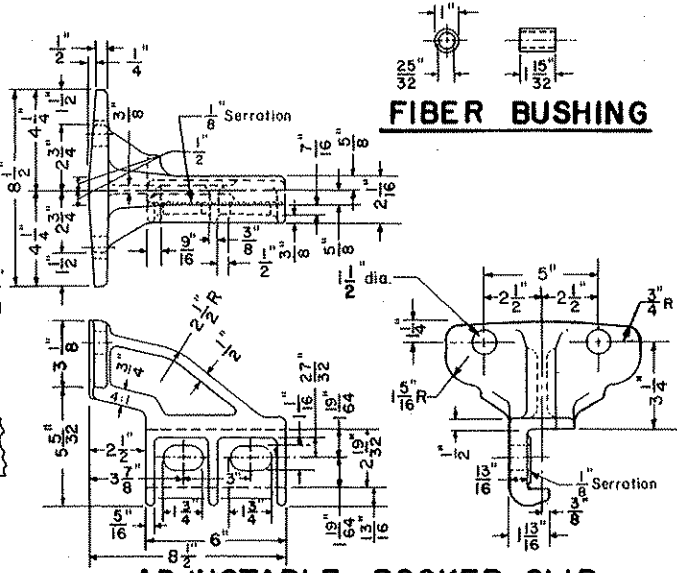

ADJUSTABLE ROCKER CLIP

FIBER BUSHING

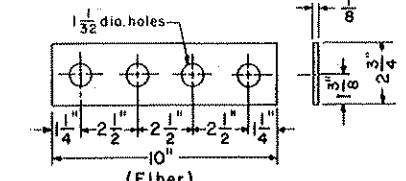

INSULATION PLATE FOR SPLICE PLATE

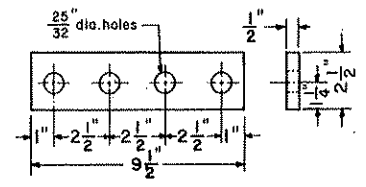

SPLICE PLATE

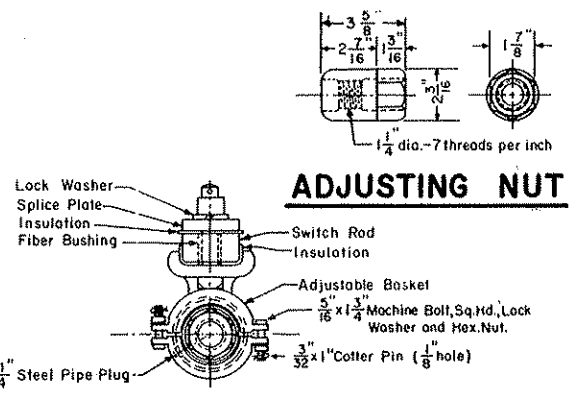

ADJUSTING NUT

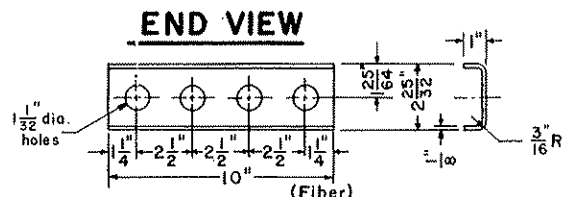

END VIEW

INSULATION FOR CHANNEL

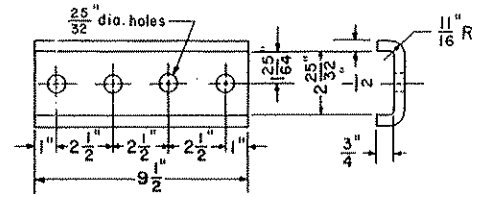

CHANNEL - STEEL

NOTES



- 1- All switch rods shall conform to current A.R.E.A. Specifications.
- 2- All fiber parts shall conform to current A.A.R. Signal Section Manual, Part 58, Specifications 13 - Hard Fiber.
- 3- Each switch rod shall be marked with deeply cut characters, not less than 1/2" high, with rod, switch and rail designations.
- *4- No. 3 Rod is not required for turnouts with solid heel blocks but is required with floating heel blocks.

	RAILROAD OPERATIONS	DWG. NO. 2107
	Oct. 28, 1992 ISSUE DATE	(2) ISSUE NO.
VERTICAL SWITCH RODS AND ADJUSTABLE ROCKER CLIPS FOR 16'-6" SWITCH-115 LB. OR 132 LB. RE RAIL		
<i>John P. Ray</i> ENGINEERING OFFICER	<i>W. A. 2. [Signature]</i> CHIEF ENGINEERING OFFICER	

NO. 10 TURNOUT WITH FLOATING HEEL BLOCKS -
BILL OF MATERIAL

QUANTITY	DESCRIPTION	REFERENCE PLAN NO.
1*	PAIR 27'-0" SWITCH POINTS COMPLETE WITH REINFORCING BARS, CLIPS AND STOPS ATTACHED.	2114
2	FLOATING HEEL BLOCKS	2350
2	60'-0" UNDERCUT STOCK RAILS	2360
1	INSULATED GAGE PLATES (NO. 10)	2106
2	NO. 0 ADJUSTABLE BRACE SLIDE PLATES	2106
6	NO. 1 ADJUSTABLE BRACE SLIDE PLATES	2106
2	NO. 1A ADJUSTABLE BRACE SLIDE PLATES	2106
8	NO. 1P SHOULDER SLIDES PLATES	2106
4	NO. HP HEEL PLATES	2106
2	SWITCH RAIL STOPS	2350
6	ADJUSTABLE ROCKER CLIPS FOR VERTICAL SWITCH RODS	2107
3	INSULATED VERTICAL SWITCH RODS (NO. 1, 2 & 3)	2107
22*	TURNOUT PLATES FOR USE BEHIND HEEL OF SWITCH (NO. 10-2 R/L TO 10-5 R/L & NO. 10-6 TO 10-12)x2	2342
12	RESILIENTLY FASTENED ADJUSTABLE RAIL BRACE	2352
1	NO. 10 RAILBOUND MANGANESE STEEL FROG, COMPLETE	2105
10	NO. P27 SELF ALIGNING SHOULDER TIE PLATE	2328
12	NO. P31 SELF ALIGNING SHOULDER TIE PLATE	2328
4	NO. P35 SELF ALIGNING SHOULDER TIE PLATE	2328
4	NO. PR27 SELF ALIGNING SHOULDER TIE PLATE	2328
2	NO. PR31 SELF ALIGNING SHOULDER TIE PLATE	2328
2	13'-3" MANGANESE STEEL ONE PIECE GUARD RAILS	2302
2	19'-6" BONDED INSULATED JOINT PLUG RAIL	1340
2	78'-0" LENGTHS OF FULLY HEAT TREATED RAIL	-
-	39'-0" LENGTHS OF FULLY HEAT TREATED RAIL	-
1 EA.	VARIOUS LENGTHS OF FULLY HEAT TREATED RAIL AS FOLLOWS: 40'-10 $\frac{1}{2}$ ", 24'-6", 24'-6", 21'-6 $\frac{1}{2}$ "	-
840	$\frac{1}{2}$ " SCREW SPIKES	1218
58**	$\frac{1}{2}$ " x 6" TRACK DRIVE SCREWS	1217
404	RESILIENT FASTENER SPRING CLIPS - TYPE "E"	-
8	RESILIENT FASTENER SPRING CLIPS - TYPE MODIFIED "E"	-
14	1:80 CANT TRANSITION TIE PLATES	2348
126	RESILIENT FASTENER TIE PLATES FOR SCREW SPIKES	1225
16	STANDARD JOINT BAR ASSEMBLIES	1322
64	STANDARD TRACK BOLTS WITH NUTS & WASHERS	1332

* THESE ITEMS SHALL BE SUPPLIED FOR R.H., L.H. OR EQUILATERAL TURNOUT, AS REQUIRED.
+ FOR EQUILATERAL TURNOUTS, CLOSURE RAILS HAVE SLIGHTLY DIFFERENT LENGTHS.
** SUPPLIED BY THE INSTALLER

	MASSACHUSETTS BAY TRANSPORTATION AUTHORITY	RAILROAD OPERATIONS	DWG. NO. 2110
			JAN. 5, 1996 ISSUE DATE
			(2) ISSUE NO.
NO. 10 FLOATING HEEL BLOCK TURNOUT BILL OF MATERIAL			
 SECTION CHIEF			

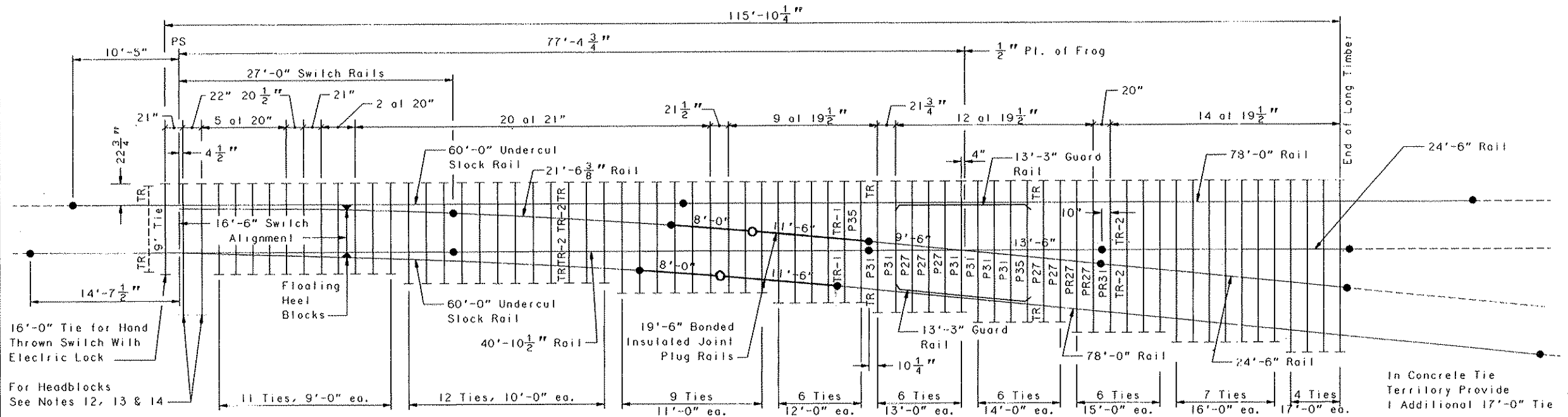

FROG TIE PLATES

- 10 - P27 SAS (Self-Aligning Shoulder)
- 12 - P31 SAS
- 4 - P35 SAS
- 4 - PR27 SAS
- 2 - PR31 SAS

NOTES

- 1-Stock rails and switch points and all rails furnished to be fully heat treated.
- 2-Switch Points per A.R.E.A. Detail 5100 as shown on Plan 2104.
- 3-60' stock rails, to be undercut as per Plan 2360.
- 4-For switch details see Plan 2114.
- 5-Gage plate No. 1 - 6 as per Plan 2106.
- 6-Switch plates Nos. 0, 1, 1A, 1P and 1P as per Plan 2106.
- 7-Turnout plates, No. 2 thru No. 12, as per Plan 2342.
- 8-Vertical insulated switch rods and adjustable rocker clips, as per Plan 2107.
- 9-Floating Heel block as per Plan 2350.
- 10-All rails to be drilled as shown on this plan, except that first hole is not to be drilled by the manufacturer. Installer to field drill first hole when necessary.
- 11-All tie plates to be resiliently fastened except guard rails.
- 12-Two 9"x10"x13' Headblocks needed with switch stand 3' high or less; 16' long with stands over 3'.
- 13-Three 9"x10"x16' Headblocks needed for hand thrown switch with electric lock.
- 14-Two 9"x10"x12' Headblocks needed for power operated switch.
- 15-See Plan 2110 for Bill of Material.
- 16-Rail lengths are computed to allow a 1/8" gap for temporarily bolting the field joints and 3/16" gap for insulated joints. When rails are welded in the field, they must be cut to provide gaps recommended by the weld kil manufacturer.
- 17-Transition Plates (TR) 1:80 Cont., as per Plan 2348.

LEGEND

- Indicates rails furnished by the manufacturer.
- Indicates rails furnished by the installer.
- Indicates "floating" heel blocks.
- Indicates insulated joints with 3/16" opening.
- Indicates joints to be field welded.
- Indicates Bonded Insulated Joint Plug Rail

LONG TIMBERS REQUIRED

Quantity	Length
12*	9'-0"
12	10'-0"
9	11'-0"
6	12'-0"
6	13'-0"
6	14'-0"
6	15'-0"
7	16'-0"
4**	17'-0"
68	Total

*Headblocks not shown in table, see notes 12, 13 & 14.
 ** 11 with electric lock
 *** 5, 17'-0" lies in concrete tie territory

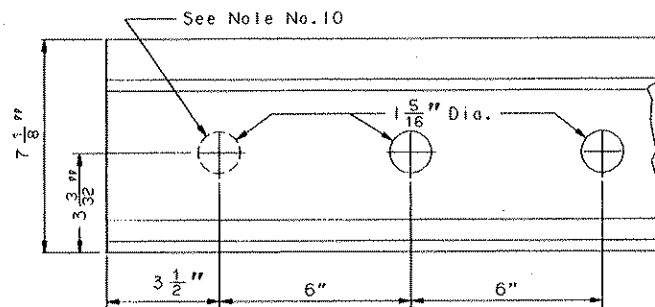
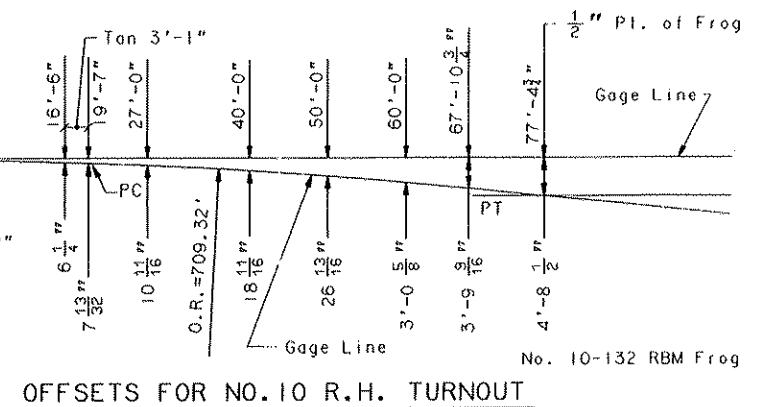

RAIL END DRILLING

	MASSACHUSETTS BAY TRANSPORTATION AUTHORITY	RAILROAD OPERATIONS	DWG. NO. 2112
			JAN. 5, 1996
		ISSUE DATE	ISSUE NO. 2

NO. 10 TURNOUT WITH FLOATING HEEL BLOCKS - TIE & RAIL LAYOUT

John D. Roney
 SECTION CHIEF

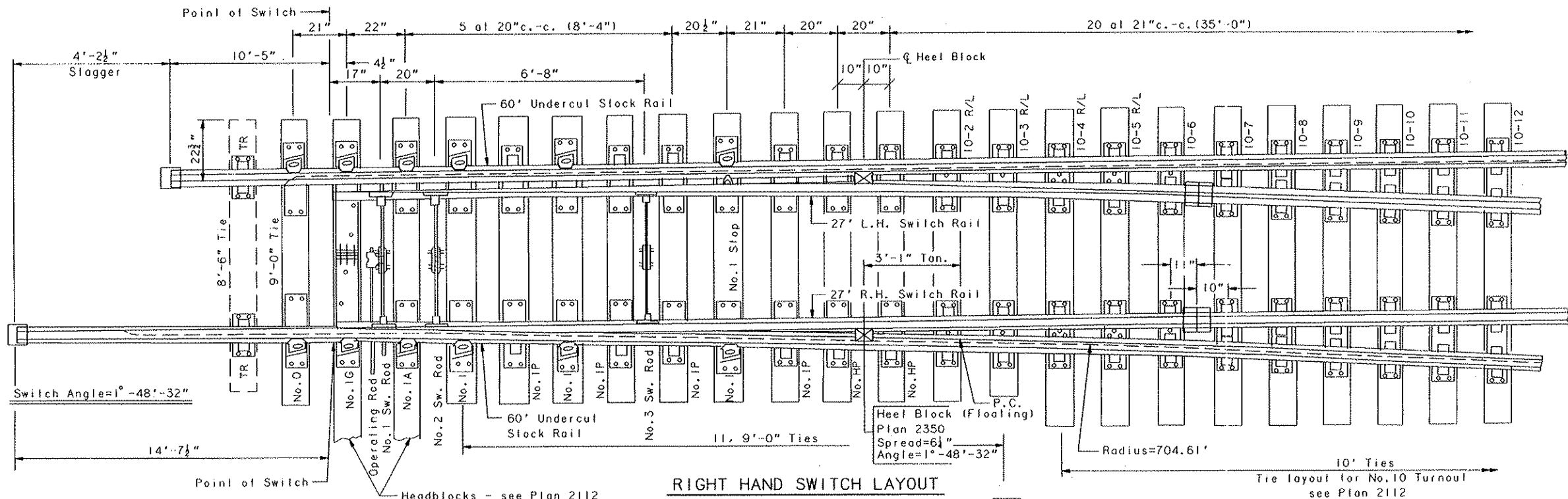

RIGHT HAND SWITCH LAYOUT

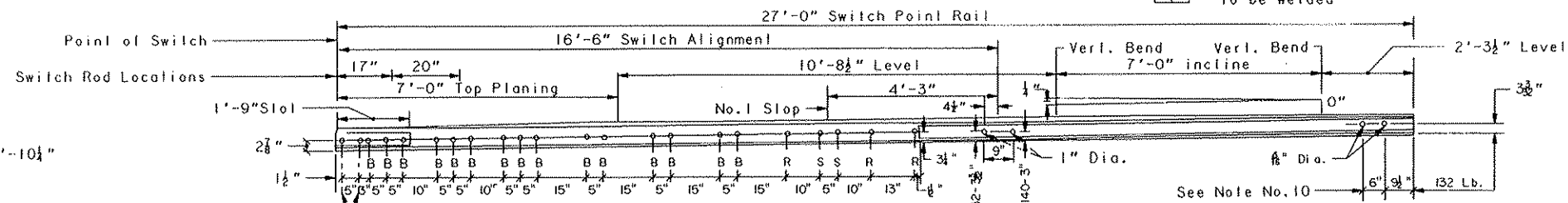

ELEVATION OF SWITCH RAIL

"B" = 1" Dia. H.T. machine bolts with square nuts, spring washers and collar pins. Hex nuts at rocker clips.
 "R" = 3/4" Dia. rivets.
 "S" = 3/4" machine bolts for stops with square nuts, spring washers and 3/4" collar pins.

NOTES

1. - This plan for use with A.R.E.A. recommended standards for 132 R.E..
2. - Workmanship and materials shall be as per current A.R.E.A. Specifications.
3. - Gage Plate 1-G as shown on Plan 2106.
4. - Switch Plates Nos. 0, 1, 1a, 1p, HP shown on Plan 2106.
5. - Turnout Plates No. 2 thru No. 12 as shown on Plan 2342.
6. - Stock Rails to be undercut as per Plan 2360.
7. - Switch Rails to be undercut per A.R.E.A. Design 5100.
8. - All rails to be Fully Heat Treated.
9. - Vertical insulated switch rods and adjustable rocker clips as per Plan 2107.
10. - All rails, including switch rails, to be drilled per Plan 2112 for 132 R.E. rail, with the first hole not to be drilled by manufacturer. Installer to field drill first hole when necessary.
11. - See Plan 2110 for Bill of Material.
12. - All bolts shall be dipped in a non oxidizing grease immediately before applying so that all threads are thoroughly coated.

For placing of special plates 10-2 thru 10-12, see Plan 2342.

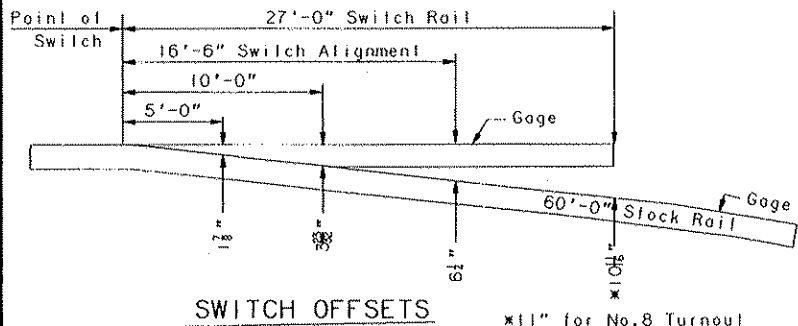

SWITCH OFFSETS

	MASSACHUSETTS BAY TRANSPORTATION AUTHORITY	RAILROAD OPERATIONS	DWG. NO. 2114
			JAN. 5, 1996 ISSUE DATE
16'-6" STRAIGHT SPLIT SWITCH WITH FLOATING HEEL BLOCKS			(2) ISSUE NO.
 SECTION CHIEF			

BILL OF MATERIAL FOR A NO. 15 TURNOUT

Quantity	Description	Reference Plan No.
* 1	Pair of 26'-0" Switch Points, complete with reinforcing bars, clips and stops attached	2155
2	Heel Block Assemblies, complete	2350
* 2	39'-0" Undercut Stock Rails	2155
3	Insulated Gage Plates (Nos. O-G, I-G, 2-G)	2155
8	No. 1 Adjustable Brace Slide Plates	2157
2	No. 3 Adjustable Brace Slide Plates	2157
12	No. 1-P Shoulder Slide Plates	2157
2	No. 2 Shoulder Slide Plates	2157
2	No. 4 Shoulder Slide Plates	2157
2	No. SH Heel Plates, I-RH and I-LH	2157
4	Switch Rail Stops	2350
8	Adjustable Rocker Clips for Vertical Switch Rods	2158
4	Insulated Vertical Switch Rods (No. 1, 2, 3 & 4)	2158
26	Turnout Plates for use behind heel of switch (15-2 to 15-14 x 2)	2340
16	Resiliently Fastened Adjustable Rail Brace	2352
1	No. 15 Railbound Manganese Steel Frog, Complete	2156
7	FT20 Hook Twin Tie Plates	2326
6	FT23 " " " "	"
16	FT27 " " " "	"
1	FT29 " " " "	"
—	FT33 " " " "	"
2	FT23 Modified Hook Twin Tie Plates	"
2	FT27 " " " " "	"
—	FT29 " " " " "	"
—	FT33 " " " " "	"
2	FTR27 Hook Twin Tie Plates	"
2	FTR29 " " " "	"
2	FTR31 " " " "	"
2	FTR33 " " " "	"
4	FTR27 Modified Hook Twin Tie Plates	"
—	FTR29 " " " " "	"
—	FTR31 " " " " "	"



* These items shall be supplied for R.H., L.H. or Equilateral Turnout as required.

Quantity	Description	Reference Plan No.
—	FTR33 Modified Hook Twin Tie Plates	2326
2	13'-3" Manganese Steel One Piece Guard Rails	2302
—	Bolted, Poly Type Insulated Joint Assembly	—
2	19'-6" Bonded Insulated Joint Plug Rail	1340
6	39'-0" Lengths of Fully Heat Treated Rail	—
1 ea. †	Various Lengths of Fully Heat Treated Rail as follows: 38'-2 9/16", 36'-8", 35'-0", 28'-7 3/4", 27'-9", 26'-8 1/2", 21'-8", 19'-9 1/4"	—
1840	7" Lock Spikes	1216
120	5/8" x 6" AREA Spikes **	1210
760	Resilient Fastener Spring Clips - Type "E"	—
16	Resilient Fastener Spring Clips - Type Modified "E"	—
310	Standard Resilient Fastener Tie Plates	1224
—	Pairs of Modified Joint Bar Assemblies (Head & Toe of Gage Side Bars Removed to Allow Switch Movement at Joint near Heel of Switch - No. 20 only)	2202
22	Standard Joint Bar Assemblies	1322 or 1320
88	Standard Track Bolts with Nuts and Washers	1332

- ** Cut Spikes to be furnished by the installer.
- Weld Kits (22) to be furnished by the installer.
- † For Equilateral Turnout, closure rails have slightly different lengths, See Equilateral Drawing (2153).

Notes:

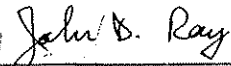
1. Turnouts supplied shall be either 115 or 132 LB. RE as specified in the order.
2. Turnouts shall be resiliently fastened throughout, except Frog Tie Plates, Guard Rails and locations where Spring Clips cannot be physically installed such as on turnout plates near heel.
3. Fabricator shall supply all material required for the complete installation of the turnout except switch timber unless otherwise specified in the order.
4. For Switch Timber Schedule, see Plan: 2152.

 MASSACHUSETTS BAY TRANSPORTATION AUTHORITY	RAILROAD OPERATIONS	DWG. NO. 2150
	Oct. 28, 1992 ② <small>ISSUE DATE ISSUE NO.</small>	
<h3 style="margin: 0;">NO. 15 TURNOUT BILL OF MATERIAL</h3> <div style="display: flex; justify-content: space-between; margin-top: 10px;"> <div style="text-align: center;">  ENGINEERING OFFICER </div> <div style="text-align: center;">  CHIEF ENGINEERING OFFICER </div> </div>		

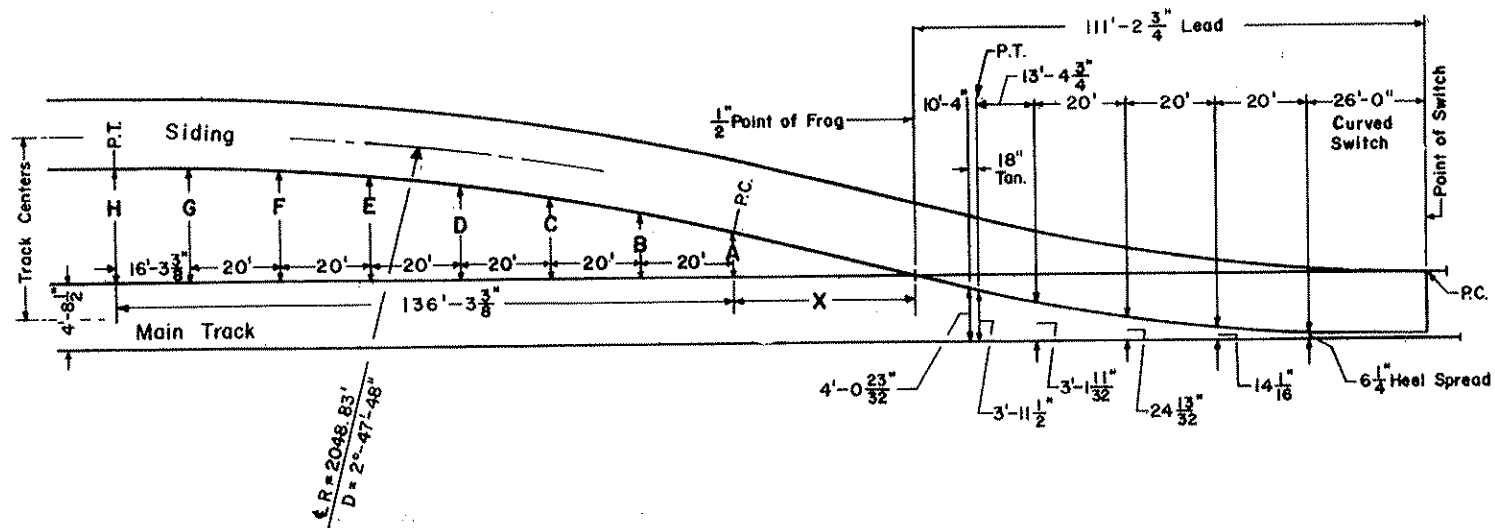

TURNOUT DATA FOR BOLTED TRACK

FROG - R.B.M.

Number	-----	15
Angle	-----	3°-49'-06"
Toe Length	-----	10'-4"
Heel Length	-----	16'-4"
Total Length	-----	26'-8"

SWITCH RAILS

Length	-----	26'-0"
Type	-----	Curved
Switch Angle For Undercut Points	-----	0°-44'-47"
Heel Block Angle	-----	1°-32'-57"
Point of Curve (P.C.)	-----	At Switch Point

LEAD

Point of Switch to 1/2 Point of Frog	-----	111'-2 3/4"
Radius	-----	1853.415'
Degree of Curve	-----	3°-05'-30" <i>2560</i>
Length of Curved Closure Rail	-----	75'-0"
Length of Straight Closure Rail	-----	74'-10 3/4"

OFFSETS BEHIND THE HEEL OF FROG

TRACK CENTERS	X	A	B	C	D	E	F	G	H
12'-2"	43'-0 11/16"	2'-11"	4'-1 13/16"	5'-2 5/16"	6'-0 7/16"	6'-8 3/16"	7'-1 5/8"	7'-4 3/4"	7'-5 1/2"
12'-4"	45'-6 5/8"	3'-1"	4'-3 13/16"	5'-4 5/16"	6'-2 7/16"	6'-10 3/16"	7'-3 5/8"	7'-6 3/4"	7'-7 1/2"
12'-6"	48'-0 5/8"	3'-3"	4'-5 13/16"	5'-6 5/16"	6'-4 7/16"	7'-0 3/16"	7'-5 5/8"	7'-8 3/4"	7'-9 1/2"
12'-8"	50'-6 5/8"	3'-5"	4'-7 13/16"	5'-8 5/16"	6'-6 7/16"	7'-2 3/16"	7'-7 5/8"	7'-10 3/4"	7'-11 1/2"
12'-10"	53'-0 9/16"	3'-7"	4'-9 13/16"	5'-10 5/16"	6'-8 7/16"	7'-4 5/16"	7'-9 5/8"	8'-0 3/4"	8'-1 1/2"
13'-0"	55'-6 9/16"	3'-9"	4'-11 13/16"	6'-0 5/16"	6'-10 7/16"	7'-6 3/16"	7'-11 5/8"	8'-2 3/4"	8'-3 1/2"
13'-2"	58'-0 1/2"	3'-11"	5'-1 13/16"	6'-2 5/16"	7'-0 7/16"	7'-8 3/16"	8'-1 5/8"	8'-4 3/4"	8'-5 1/2"
13'-4"	60'-6 3/8"	4'-1"	5'-3 13/16"	6'-4 5/16"	7'-2 7/16"	7'-10 3/16"	8'-3 5/8"	8'-6 3/4"	8'-7 1/2"
13'-6"	63'-0 3/8"	4'-3"	5'-5 13/16"	6'-6 5/16"	7'-4 7/16"	8'-0 3/16"	8'-5 5/8"	8'-8 3/4"	8'-9 1/2"

NOTE: VALUES FOR TRACK CENTERS NOT SHOWN MAY BE DETERMINED BY INTERPOLATION.

NOTES

- The lines of the diagram indicate gage lines.
- For details see the following plans:
 - Switch- 2155 or 2156
 - Frog-RBM- 2156
- For welded turnouts see Plan 2152 or 2162 for offsets between the point of switch and the toe of frog.

T	MASSACHUSETTS BAY TRANSPORTATION AUTHORITY	RAILROAD OPERATIONS	DWG. NO. 2151
			Oct. 28, 1992 2 ISSUE DATE ISSUE NO.
OFFSETS FOR NO. 15 TURNOUT 115 OR 132 R.E. RAIL-UNDERCUT			
<i>John D. Ray</i> ENGINEERING OFFICER		<i>Wa 2 [Signature]</i> CHIEF ENGINEERING OFFICER	

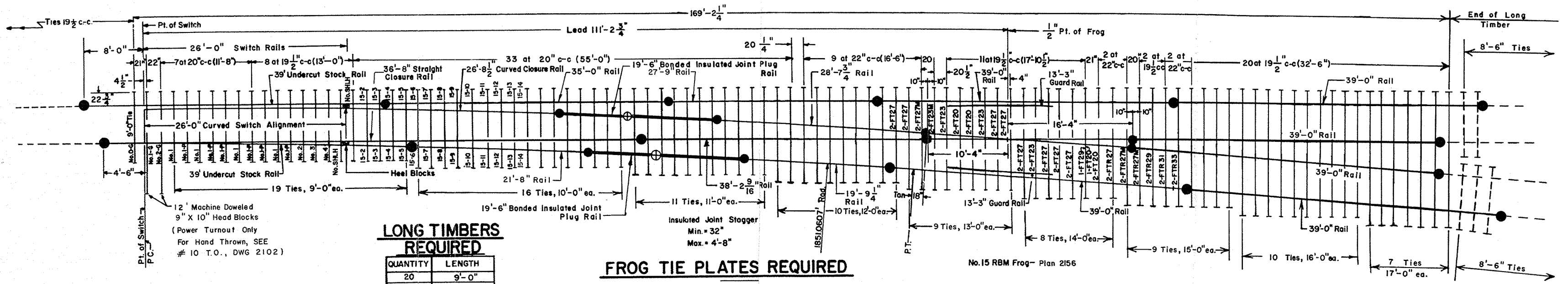

NOTES

- 1- Stock rails and switch points and all rails furnished with the turnout to be fully heat treated.
- 2- Switch Points per A.R.E.A. Detail 5100 as shown on plan 2155.
- 3- 39' stock rails, to be undercut as per Plan 2155.
- 4- For switch detail see Plan 2155.
- 5- Gage plates O-G, I-G and 2-G as per Plan 2157.
- 6- Switch plates Nos. 1 and I-P as per Plan 2157.
- 7- Turnout plates, No. 2 thru No. 14 as per Plan 2340
- 8- Vertical insulated switch rods and adjustable rocker clips, generally as per Plan 2158.
- 9- Heel block, as per Plan 2350.
- 10- All rails, including switch rails, to be drilled as shown on this plan, except that first hole is not to be drilled by the manufacturer. Forces, designated by the Authority, are to drill the first hole when necessary.
- 11- All tie plates to be resiliently fastened, except, frog tie plates and guard rails.
- 12- Rail lengths are computed to allow a 1/8" gap for temporarily bolting of the field welded joints and 3/16" gap for insulated joints. When rails are welded in the field, they must be cut to provide gaps recommended by the weld kit manufacturer.

LONG TIMBERS REQUIRED

QUANTITY	LENGTH
20	9'-0"
16	10'-0"
11	11'-0"
12 *	12'-0"
9	13'-0"
8	14'-0"
9	15'-0"
10	16'-0"
7	17'-0"
102	Total

* Includes 2-9" x 10" Head Blocks

FROG TIE PLATES REQUIRED

- 7 - FT 20
- 6 - FT 23
- 2 - FT 23 Modified
- 16 - FT 27
- 2 - FT 27 Modified
- 1 - FT 29
- 2 - FTR 27
- 4 - FTR 27 Modified
- 2 - FTR 29
- 2 - FTR 31
- 2 - FTR 33
- 46 Total

Plan 2326

LEGEND

- ⊕ Indicates insulated joints with 3/16" opening.
- Indicates field welded joints.
- Indicates rails furnished by the manufacturer.
- - - Indicates rails furnished by the installer.
- ▬ Indicates Factory Assembled Bonded Insulated Joint Plug Rails.

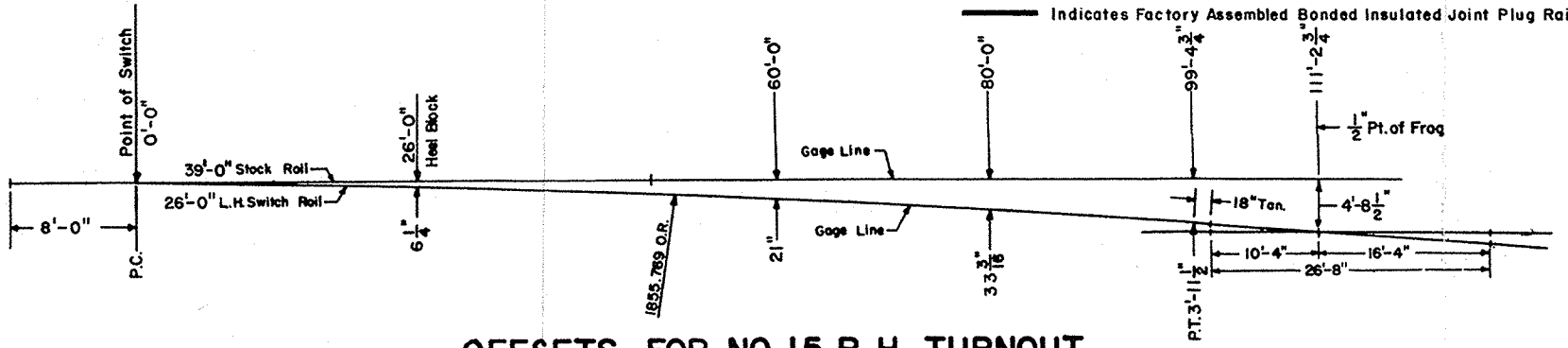
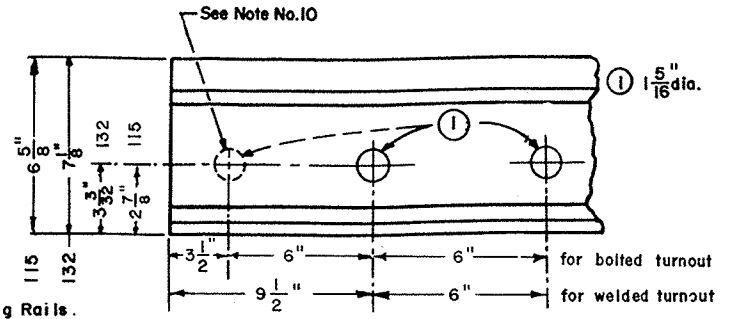

OFFSETS FOR NO. 15 R.H. TURNOUT

	RAILROAD OPERATIONS	DWG. NO. 2152 Oct. 26, 1992 ISSUE DATE
	NO. 15 WELDED TURNOUT TIE AND RAIL LAYOUT	
John D. Ray ENGINEERING OFFICER	W.A. Nelson CHIEF ENGINEERING OFFICER	

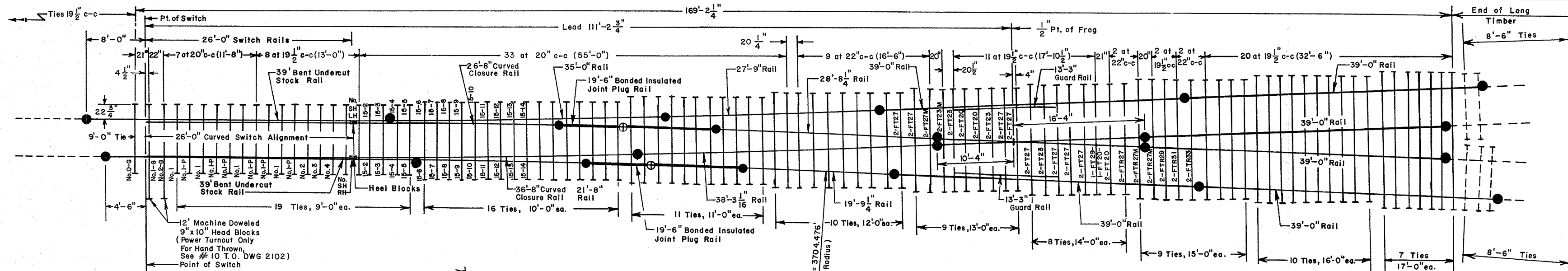

NOTES

- 1- Stock rails, switch rails and all rail furnished with the turnout to be fully heat treated.
- 2- Switch Points per A.R.E.A. Detail 5100 as shown on plan 2155.
- 3- 39' stock rails are to be undercut as shown on this plan.
- 4- Gage plates O-G, I-G and 2-G as per plan 2157.
- 5- Switch plates Nos. I and I-P as per plan 2157.
- 6- For turnout plates behind heel, see Plan 2340.
- 7- Vertical insulated switch rods and adjustable rocker clips generally as per plan 2158.
- 8- Heel blocks as per Plan 2350.
- 9- For switch details, see Plan 2155, modified as indicated for an equilateral.
- 10- All rails, including switch rails, to be drilled as shown on this sheet, except that the first hole is not to be drilled by the manufacturer. Installer to field drill first hole when necessary.
- 11- See Plan 2150 for bill of materials.
- 12- All tie plates to be resiliently fastened except frog tie plates and guard rails.
- 13- Rail lengths are computed to allow a $\frac{1}{8}$ " gap for temporarily bolting of the field welded joints and $\frac{3}{16}$ " gap for insulated joints. When rails are welded in the field, they must be cut to provide gaps recommended by the weld kit manufacturer.

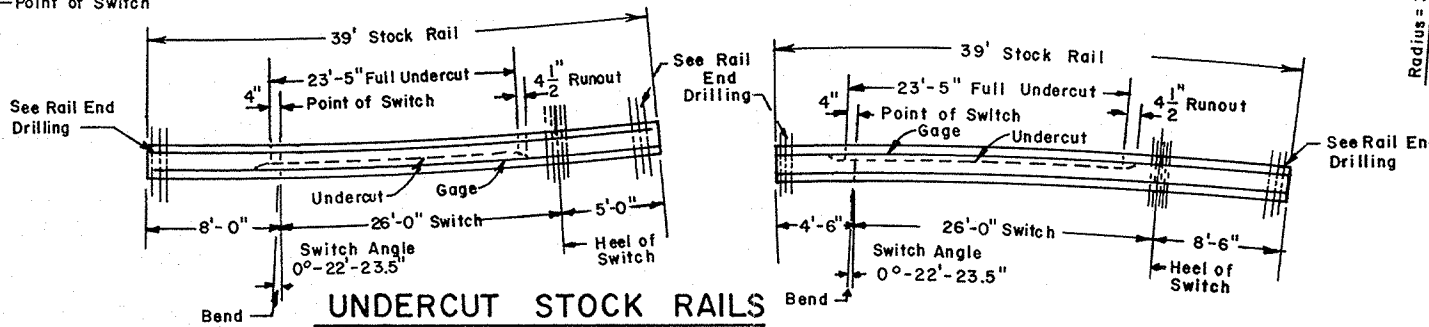

LEGEND

- Indicates rails furnished by the manufacturer.
- - - Indicates rails furnished by the installer
- ⊕ Indicates insulated joints with $\frac{3}{16}$ " Opening.
- Indicates joints to be field welded.
- Indicates Factory Assembled Bonded Insulated Joint Plug Rail.

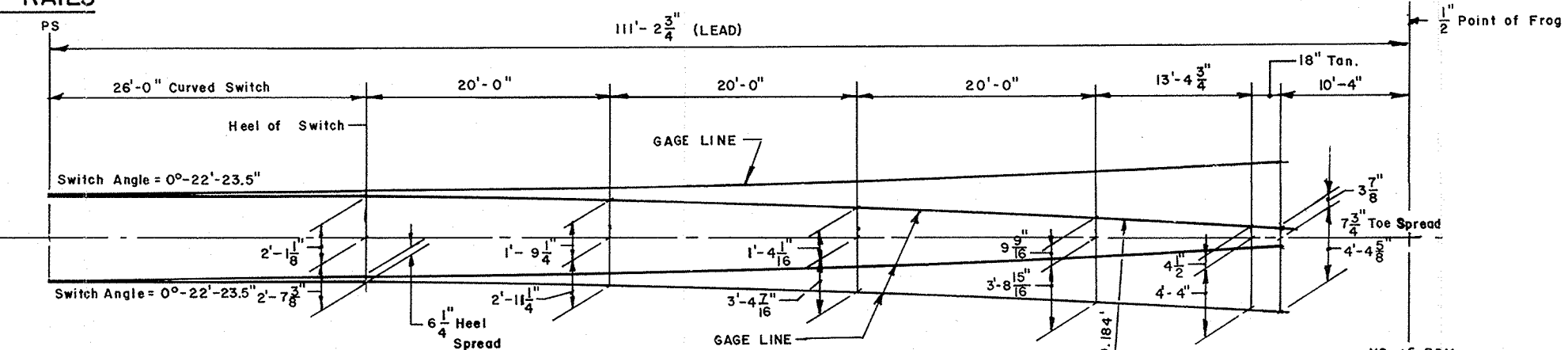
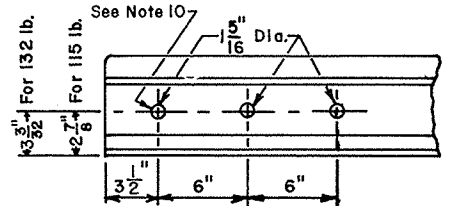

OFFSETS FOR NO. 15 EQUILATERAL TURNOUT

ALL OFFSETS SHOWN ARE TO GAGE LINES

T	MASSACHUSETTS BAY TRANSPORTATION AUTHORITY	RAILROAD OPERATIONS	DWG. NO. 2153
		NO. 15 EQUILATERAL TURNOUT TIE AND RAIL LAYOUT	OCT. 28, 1992 ISSUE DATE
John D. Ray ENGINEERING OFFICER		W.A. [Signature] CHIEF ENGINEERING OFFICER	

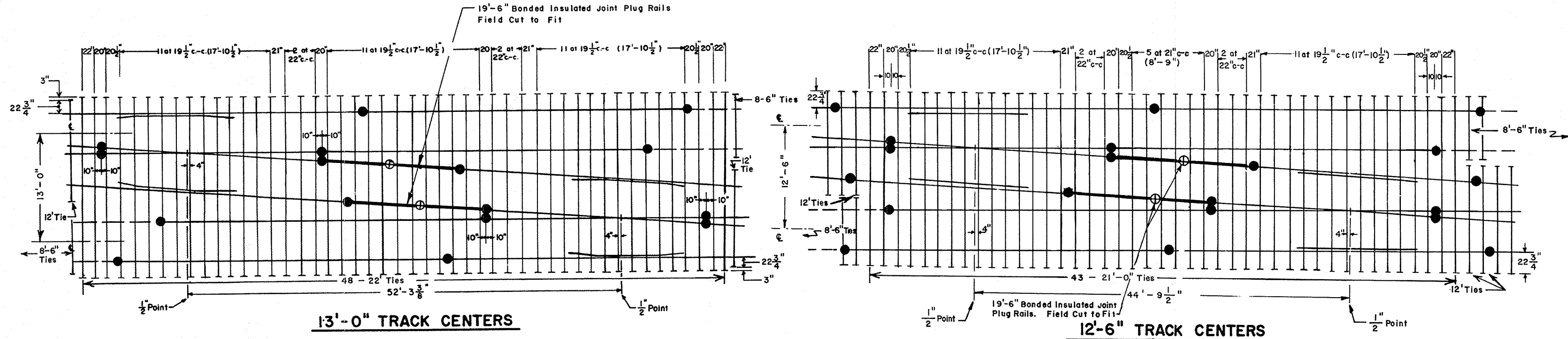

Rails shown dashed are not furnished with the turnouts and shall be supplied by the installer.

For every 1" change in track centers, the horizontal distance between $\frac{1}{2}$ " frog points will increase 15" (approx.)

For turnout see Plan 2152 or 2162 for floating heel block type turnouts.

Frog Angle = 3°-49'-06"
 Toe Length = 10'-4"
 Heel Length = 16'-4"
 Total Length = 26'-8"

NOTE: Timber layout shown is for exact track centers indicated. Other track centers require adjusting the timber schedule and timber spacing as required.

SWITCH TIMBER FOR A CROSSOVER

TRACK CENTERS	TIMBER LENGTHS						
	9'-0"	10'-0"	11'-0"	12'-0"	13'-0"	21'-0"	22'-0"
12'-6"	40	32	22	24	—	43	—
13'-0"	40	32	22	24	—	—	48
13'-6"	40	32	22	24	—	—	53

⊕ Includes 4 headblock ties

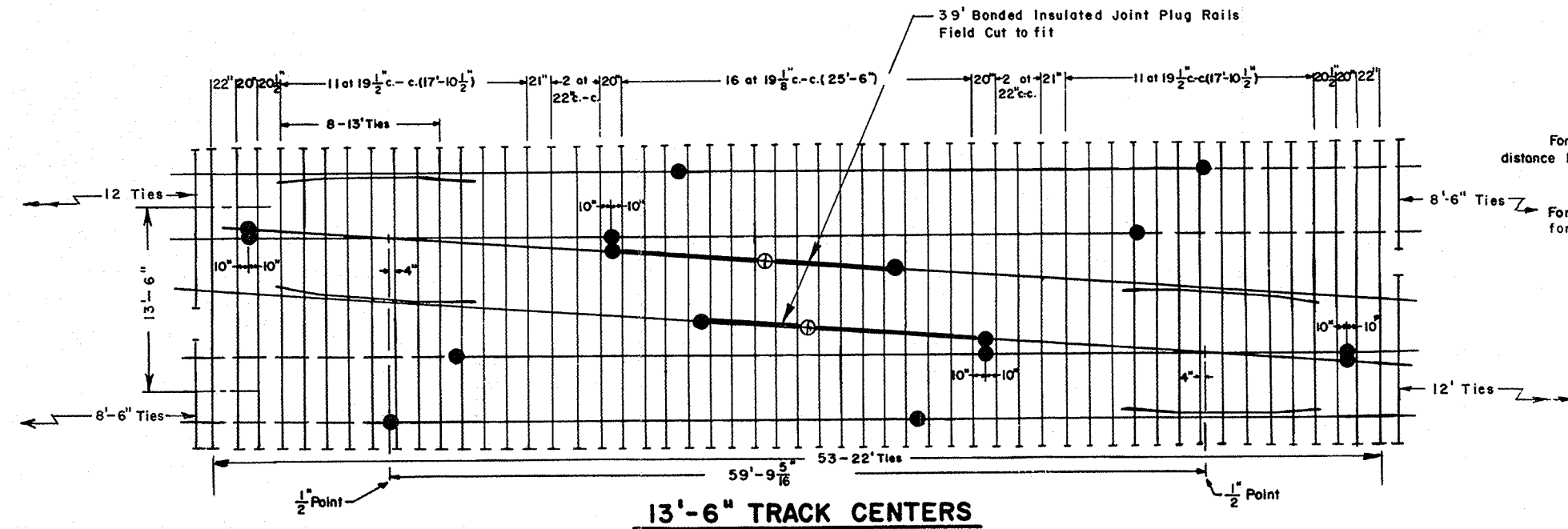

MASSACHUSETTS BAY TRANSPORTATION AUTHORITY	RAILROAD OPERATIONS	DWG. NO. 2154
		Oct. 28, 1992 <small>ISSUE DATE</small>

NO. 15 CROSSOVER TIE AND RAIL LAYOUT

ENGINEERING OFFICER
CHIEF ENGINEERING OFFICER

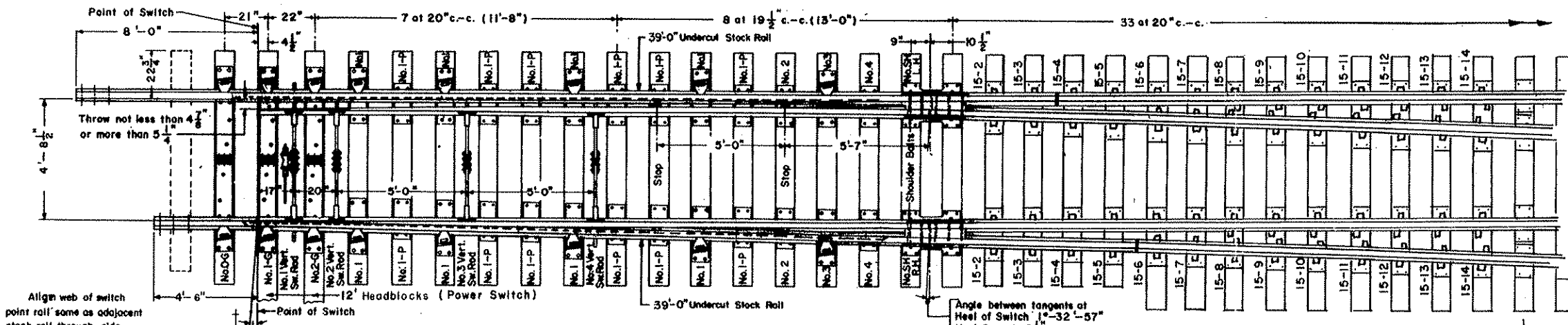

PLAN OF RIGHT HAND SWITCH LAYOUT

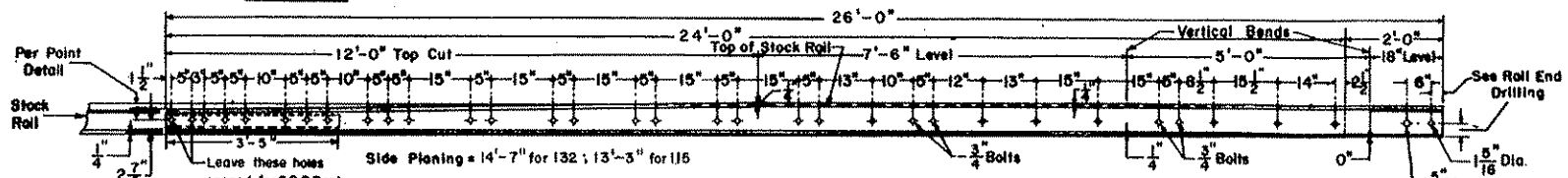

ELEVATION OF SWITCH RAIL

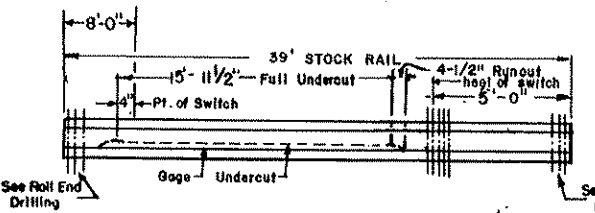

STRAIGHT STOCK RAIL

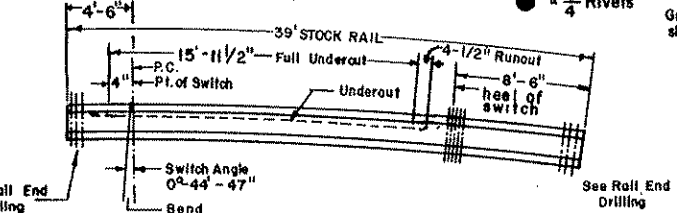

CURVED STOCK RAIL

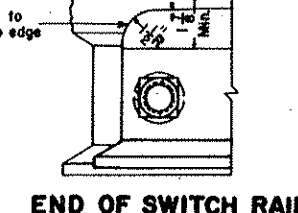

END OF SWITCH RAIL (SIDE VIEW)

TURNOUT INFORMATION

OFFSETS

TIE and RAIL LAYOUT

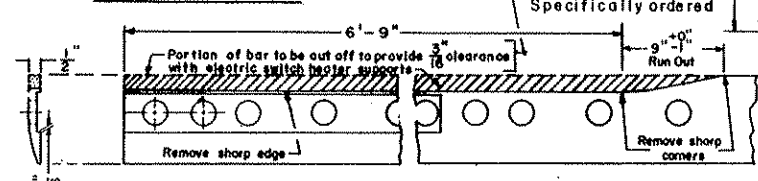

REINFORCING BAR

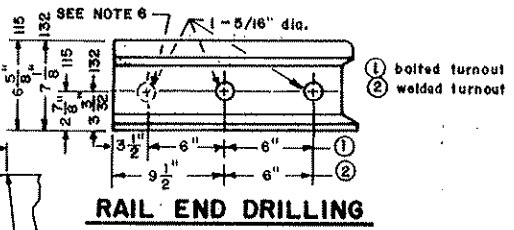

RAIL END DRILLING

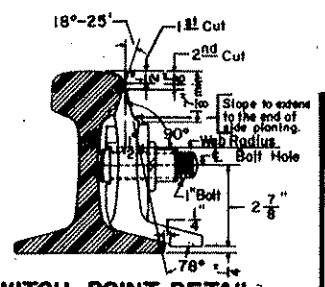

SWITCH POINT DETAIL (A.R.E.A. DESIGN 5100)

BILL OF MATERIAL

- * 1 - Pair 26'-0" Switch Points, I-R.H. straight and I-L.H. curve, complete with reinforcing bars, clips and stops attached.
 - 2 - 39'-0" Undercut Stock Rails.
 - 4 - Insulated Vertical Switch Rods, with basket. See Plan 2158.
 - 2 - Heel Block Assemblies, complete. See Plan 2350.
 - 3 - Insulated Gage Plates, No. 0-G, No. 1-G and No. 2-G
 - 8 - No. 1 Adjustable Brace Slide Plates
 - 2 - No. 3 " " " "
 - 12 - No. 1-P Shoulder Slide Plates
 - 2 - No. 2 " " " "
 - 2 - No. 4 " " " "
 - 2 - No. SH Heel Plates, I-R.H. and I-L.H.
 - 16 - Adjustable Rail Braces, Resilient Type, complete. See Plan 2352.
 - 4 - Switch Stops. See Plan 2350.
 - 8 - Adjustable Rocker Clips for Vertical Switch Rods. See Plan 2158.
 - 26 - Turnout Pocket Plates with Welded Pressed Steel Shoulders for Resilient Fasteners Plan 2540
- Standard Resilient Fastener Plates

NOTES

- 1 - This plan is for use with A.R.E.A. recommended standards for 132 or 115 RE Rail.
- 2 - Stock rails, switch rails and all supplied rail to be fully heat treated.
- 3 - All bolts shall be dipped immediately before applying (so that all threads are thoroughly coated) in grease.
- * 4 - When ordering a Left Hand Switch, these items shall be opposite hand.
- † 5 - For stock rails, switch angles, and offsets for an equilateral - see Plan 2153.
- 6 - All rails, to be drilled as shown on this plan, except, the first hole is not to be drilled by manufacturer. Installer to drill first hole.

T	MASSACHUSETTS BAY TRANSPORTATION AUTHORITY	RAILROAD OPERATIONS	DWG. NO. 2155
			Oct. 28, 1992 ISSUE DATE

26'-0" CURVED SPLIT SWITCH
115 OR 132 R.E. RAIL - INSULATED & UNDERCUT

ENGINEERING OFFICER CHIEF ENGINEERING OFFICER

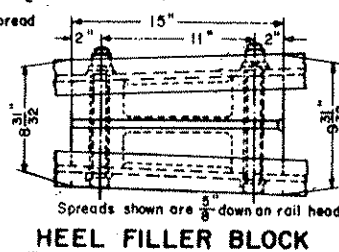
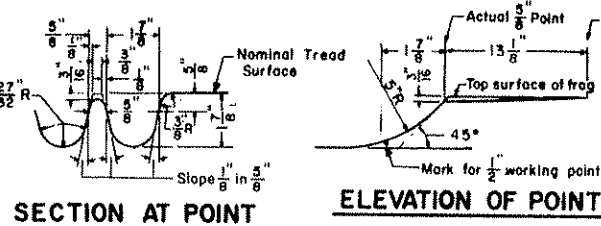
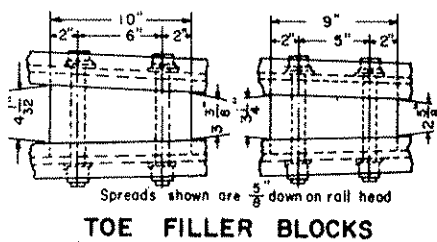
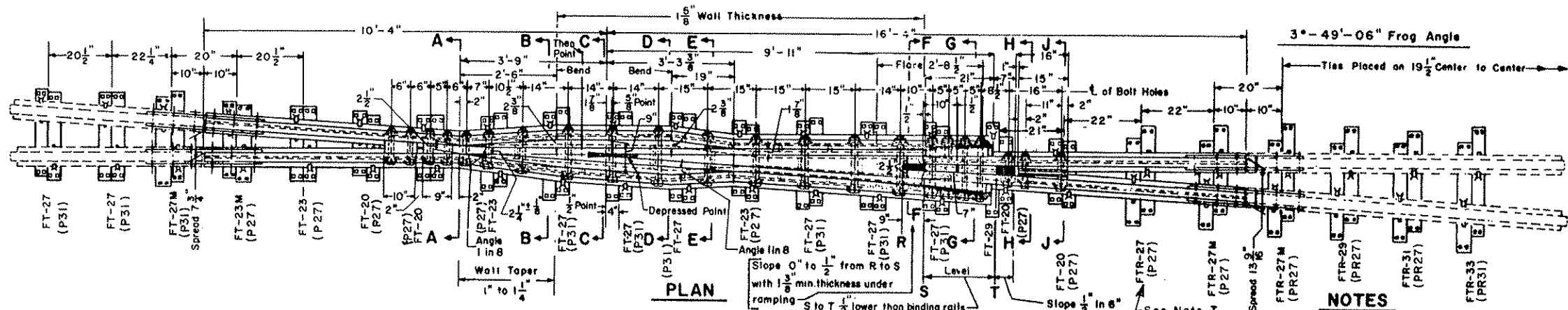

- NOTES**
- 1 - This plan is for use with A.R.E.A. recommended standards for 115 & 132 lb. R.E. Rail, Heavy Wall Section.
 - 2 - Workmanship and materials, including beveling shall be per current "A.R.E.A. Specifications".
 - 3 - Groove for bond wires shall extend from end of filler block at least to center line of second bolt.
 - 4 - All bolts used in construction of frog and switch material shall be dipped immediately before applying (so that all threads are thoroughly coated) in grease manufactured for this purpose.
 - 5 - When frog is to be used in bolted track, the first bolt hole to be drilled in the field by MBTA Forces.
 - 6 - Casting to be explosion hardened, with toe and heel arms to be fully heated rails.

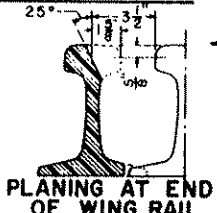
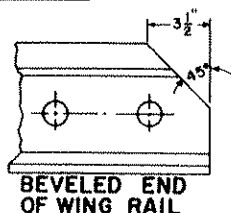
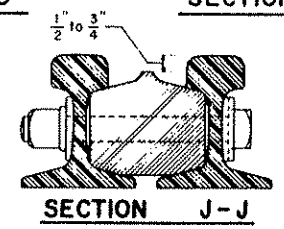
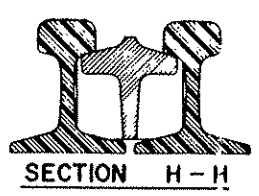
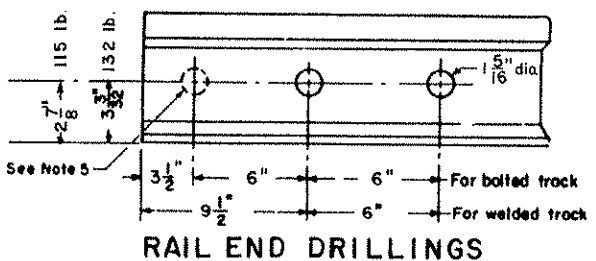
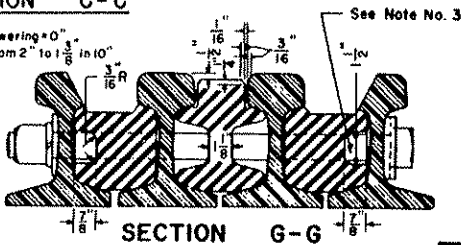
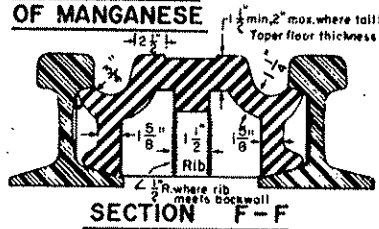
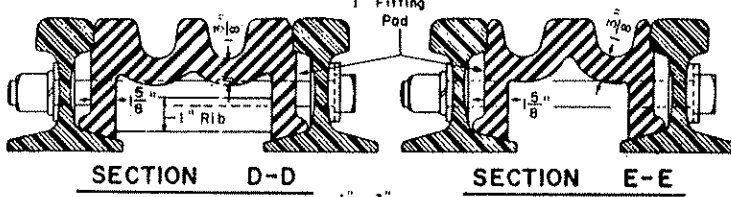
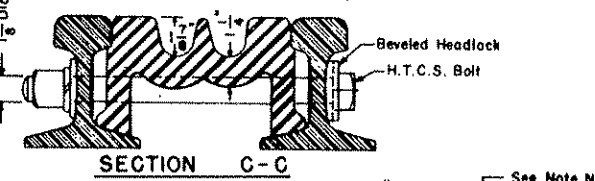
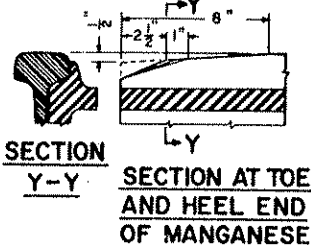
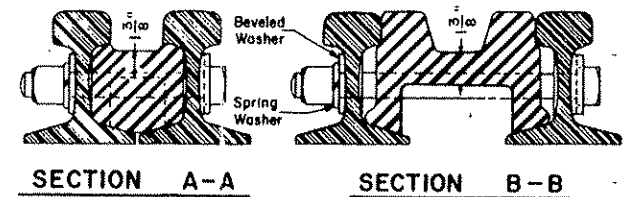

FROG TIE PLATES REQUIRED

7-FT 20	2-FTR 27
6-FT 23	4-FTR 27 Mod.
2-FT 23 Mod.	2-FTR 29
16-FT 27	2-FTR 31
2-FT 27 Mod.	2-FTR 33
1-FT 29	

OR

20-P27 SAS (Self Aligning Shoulder)	
18-P31 SAS	
6-PR27 SAS	See Note 7
2-PR31 SAS	

MASSACHUSETTS BAY TRANSPORTATION AUTHORITY	RAILROAD OPERATIONS	DWG. NO. 2156
		Jan. 5, 1996
No. 15 RAILBOUND MANGANESE STEEL FROG FOR 115 LB OR 132 LB. R.E. RAIL		ISSUE NO. 3
John D. Ray SECTION CHIEF		

Mark Plate and Switch Designation and Rail Section on Both Ends.
 OG - 26 or 39-132
 1G - 26-132
 2G - 26-132
 (See Note No. 4)

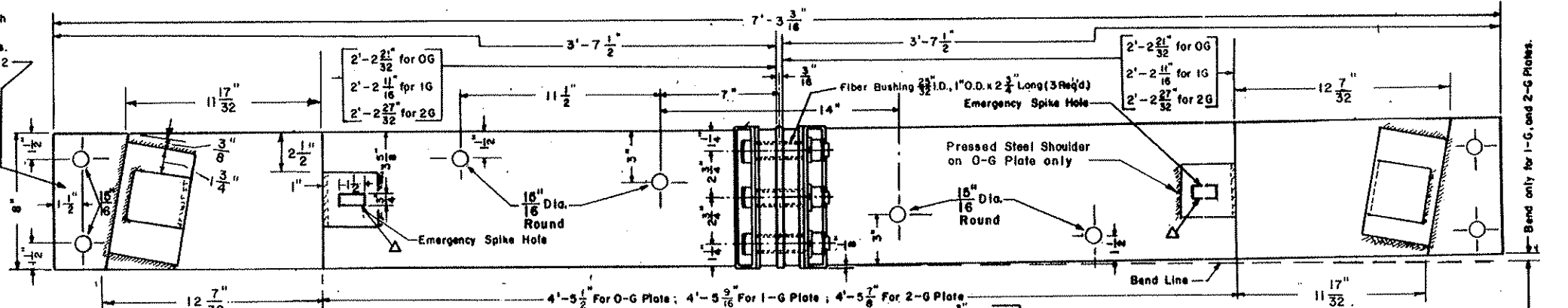

TYPICAL ALL WELDS
 Full Penetration Groove Welds on Pressed Steel Shoulders
 Full Penetration Fillet Welds on R.S. Stops
 (See Note 5)

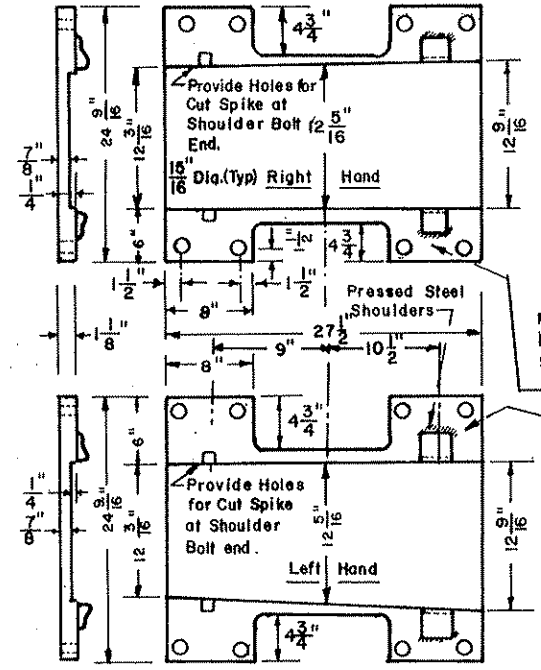
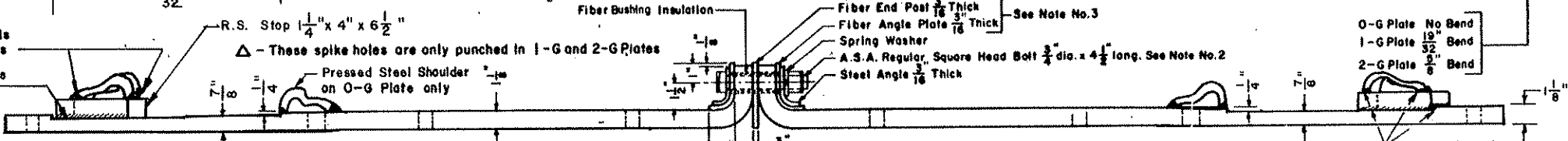

NO. SH (R.H. & L.H.) HEEL PLATES

NO. 0-G, NO. 1-G & NO. 2-G INSULATED GAGE PLATES

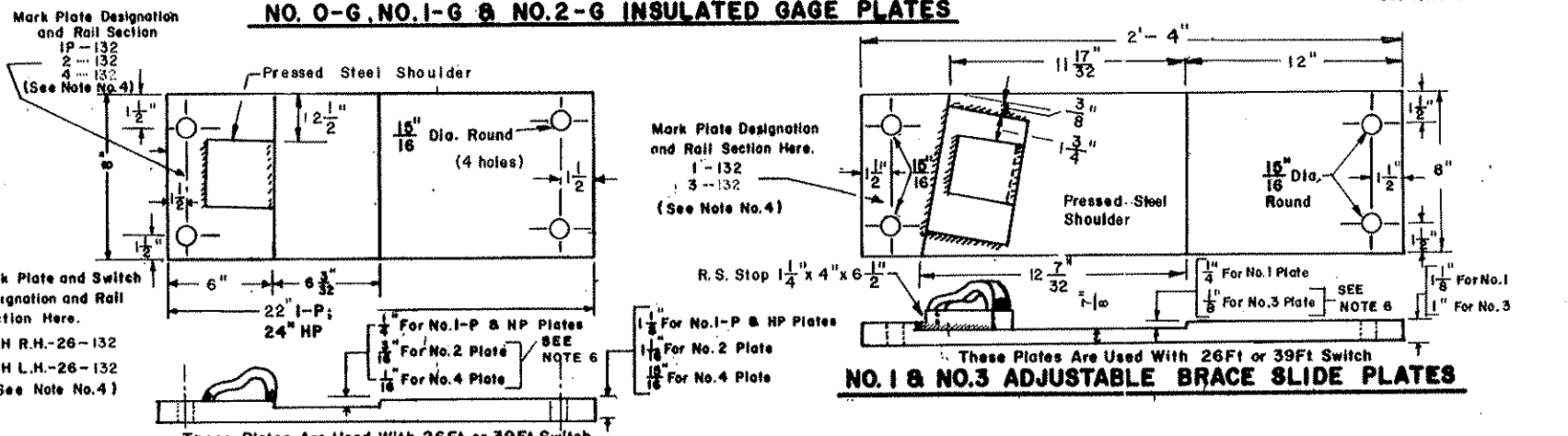

NO. 1-P, NO. 2, NO. 4 & NO. HP SHOULDER SLIDE PLATES

- NOTES:**
- Switch Plates shall conform to current A.R.E.A. Specifications for Low-Carbon Steel Tie Plates with copper.
 - All gage plate bolts shall have A.S.A. Regular square heads and A.S.A. Heavy square nuts. All bolts shall be carbon-steel with medium-carbon steel nuts and conform to current A.R.E.A. "Specifications for Heat-Treated Carbon-Steel Track Bolts and Carbon Steel Nuts."
 - All fiber parts shall conform to current A.A.R. Signal Section Manual, Part 58, Specification No. 13 for "Hard Fiber" and A.A.R. Signal Section Manual, Part No. 178 covering "Requisites for Fabricated Fiber Parts for Track Insulation."
 - Plates shall be marked with deeply cut characters, not less than 1/2" high, in the position as indicated on this plan.
 - Welds shall be made so that they do not interfere with the installation of resilient fasteners and rail braces.
 - Modify contour of pressed steel shoulder or shim plates 2, 3, & 4 to maintain uniform toe pressure from the resilient fasteners.
 - For adjustable brace used with these plates, see Dwg. 2352.

NO. 1 & NO. 3 ADJUSTABLE BRACE SLIDE PLATES

	MASSACHUSETTS BAY TRANSPORTATION AUTHORITY	RAILROAD OPERATIONS	DWG. NO. 2157
			Jan. 5, 1996
			ISSUE DATE
			ISSUE NO. (3)
SWITCH PLATES and GAGE PLATES FOR 26'-0" SWITCH-132 LB RAIL			
SECTION CHIEF			

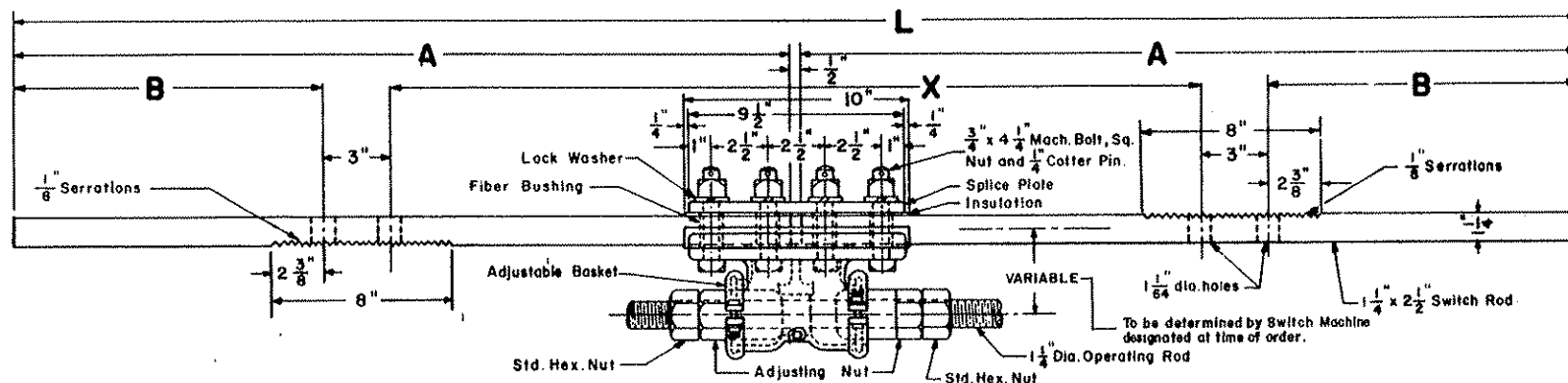

INSULATED SWITCH ROD NO. 1 WITH ADJUSTABLE BASKET

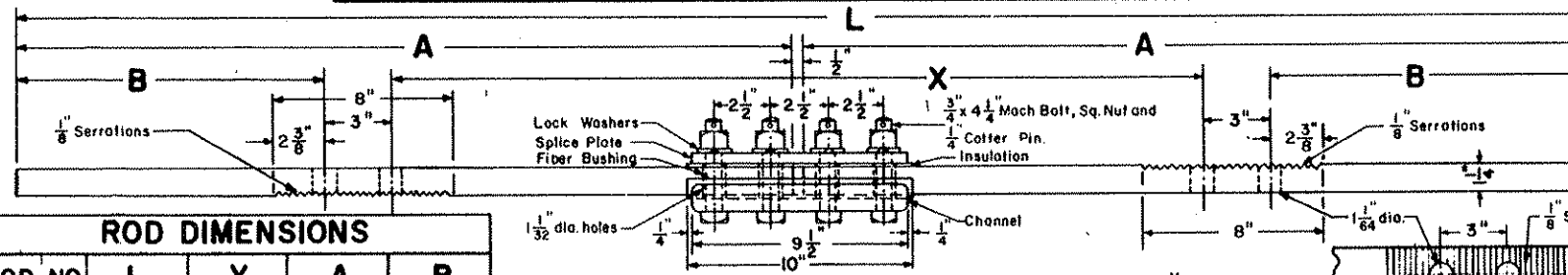

INSULATED SWITCH RODS NOS. 2, 3, 4 & 5*

ROD DIMENSIONS				
ROD NO.	L	X	A	B
1	5'-10"	2'-11 ⁷ / ₈ "	2'-10 ³ / ₄ "	14 ¹ / ₁₆ "
2	4'-4"	3'-0 ¹¹ / ₃₂ "	2'-1 ³ / ₄ "	4 ⁵⁵ / ₆₄ "
3	4'-4"	3'-1 ¹ / ₈ "	2'-1 ³ / ₄ "	4 ⁷ / ₁₆ "
4	5'-10"	3'-2 ⁷ / ₁₆ "	2'-10 ³ / ₄ "	12 ²⁸ / ₃₂ "
5*	5'-10"	3'-2 ⁷ / ₁₆ "	2'-10 ³ / ₄ "	12 ²⁵ / ₃₂ "

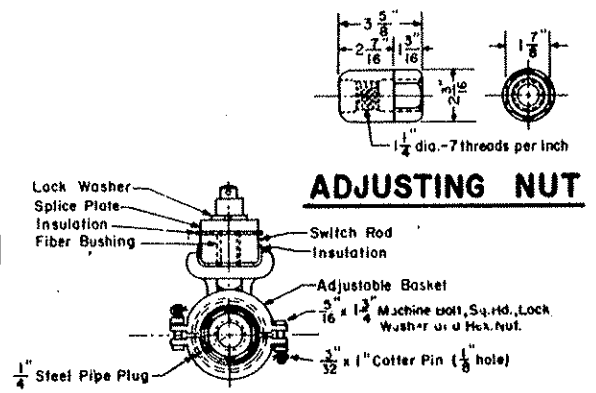

ADJUSTING NUT

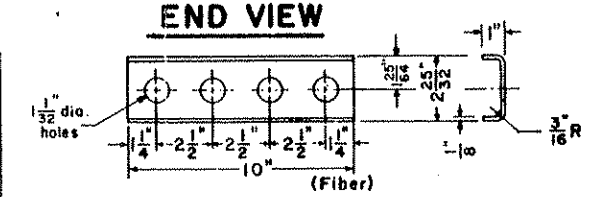

INSULATION FOR CHANNEL

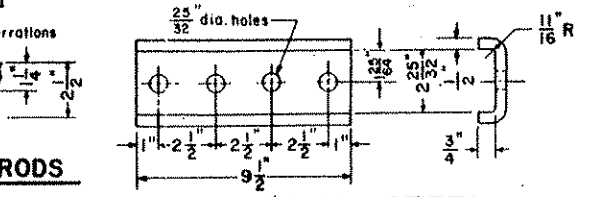

CHANNEL-STEEL

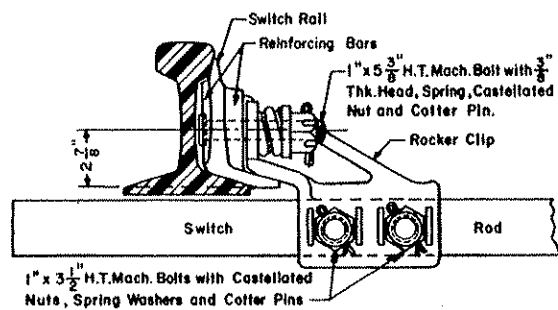

ASSEMBLED ROCKER CLIP

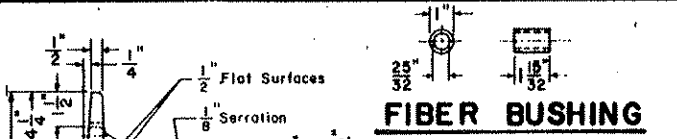

FIBER BUSHING

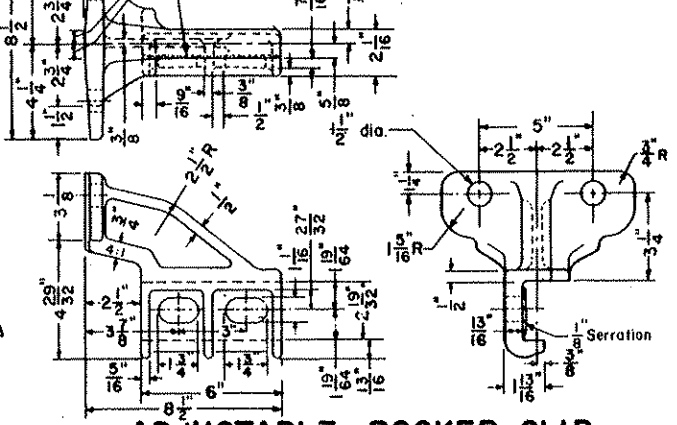

ADJUSTABLE ROCKER CLIP

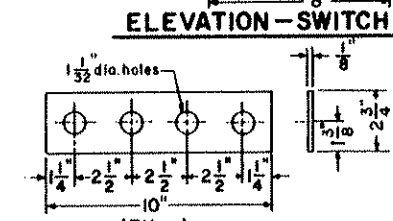

INSULATION PLATE FOR SPLICE PLATE

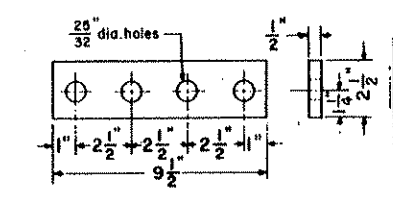

SPLICE PLATE

NOTES

- 1- All switch rods shall conform to current A.R.E.A. Specifications.
- 2- All fiber parts shall conform to current A.A.R. Signal Section Manual, Part 58, Specifications 13 - Hard Fiber.
- 3- Each switch rod shall be marked with deeply cut characters, not less than 1/2" high, with rod designation and rail section.
- *4- No. 5 Rod is not required for turnouts with solid heel blocks but is required with floating heel blocks.

T	MASSACHUSETTS BAY TRANSPORTATION AUTHORITY	RAILROAD OPERATIONS	DWG. NO. 2158
			Oct. 28, 1992 ISSUE DATE
VERTICAL SWITCH RODS AND ADJUSTABLE ROCKER CLIPS			
FOR 26'-0" SWITCH-115 LB. OR 132 LB. RE RAIL			
John D. Ray ENGINEERING OFFICER		W. A. [Signature] CHIEF ENGINEERING OFFICER	

NO. 15 TURNOUT WITH FLOATING HEEL BLOCKS -
BILL OF MATERIAL

QUANTITY	DESCRIPTION	REFERENCE PLAN NO.
1*	PAIR 38'-0" CURVED SWITCH POINTS COMPLETE WITH REINFORCING BARS, CLIPS AND STOPS ATTACHED.	2165
2	FLOATING HEEL BLOCKS	2350
2	60'-0" UNDERCUT STOCK RAILS	2360
3	INSULATED GAGE PLATES (NO. 0G, 1G, & 2G)	2157
10	NO. 1 ADJUSTABLE BRACE SLIDE PLATES	2157
16	NO. 1P SHOULDER SLIDES PLATES	2157
4	NO. HP HEEL PLATES	2157
4	SWITCH RAIL STOPS	2350
10	ADJUSTABLE ROCKER CLIPS FOR VERTICAL SWITCH RODS	2158
5	INSULATED VERTICAL SWITCH RODS (NO. 1, 2, 3, 4 & 5)	2158
20**	TURNOUT PLATES FOR USE BEHIND HEEL OF SWITCH (NO. 15-2 R/L TO 15-8 R/L & 15-9 TO 15-15) x2	2343
16	RESILIENTLY FASTENED ADJUSTABLE RAIL BRACE	2352
1	NO. 15 RAILBOUND MANGANESE STEEL FROG, COMPLETE	2156
20	NO. P27 SELF ALIGNING SHOULDER TIE PLATE	2328
18	NO. P31 SELF ALIGNING SHOULDER TIE PLATE	2328
6	NO. PR27 SELF ALIGNING SHOULDER TIE PLATE	2328
2	NO. PR31 SELF ALIGNING SHOULDER TIE PLATE	2328
2	13'-3" MANGANESE STEEL ONE PIECE GUARD RAILS	2302
2	19'-6" BONDED INSULATED JOINT PLUG RAIL	1340
2	78'-0" LENGTHS OF FULLY HEAT TREATED RAIL	-
3	39'-0" LENGTHS OF FULLY HEAT TREATED RAIL	-
1 EA.+	VARIOUS LENGTHS OF FULLY HEAT TREATED RAIL AS FOLLOWS: 62'-10 1/2", 22'-9 1/2", 20'-8"	-
1276	1/4" SCREW SPIKES	1218
62**	1 1/2" x 6" TRACK DRIVE SPIKES	1217
528	RESILIENT FASTENER SPRING CLIPS - TYPE "E"	-
8	RESILIENT FASTENER SPRING CLIPS - TYPE MODIFIED "E"	-
190	RESILIENT FASTENER TIE PLATES FOR SCREW SPIKES	1225
14	1:80 CANT TRANSITION TIE PLATES	2348
1	FLAT PLATE TIE PLATE	2348
19	STANDARD JOINT BAR ASSEMBLIES	1322
76	STANDARD TRACK BOLTS WITH NUTS & WASHERS	1332

* THESE ITEMS SHALL BE SUPPLIED FOR R.H., L.H. OR EQUILATERAL TURNOUT, AS REQUIRED
+ FOR EQUILATERAL TURNOUTS, CLOSURE RAILS HAVE SLIGHTLY DIFFERENT LENGTHS
** SUPPLIED BY THE INSTALLER

T MASSACHUSETTS BAY TRANSPORTATION AUTHORITY	RAILROAD OPERATIONS	DWG. NO. 2160
		JAN. 5, 1996 ISSUE DATE

NO. 15 FLOATING HEEL BLOCK TURNOUT
BILL OF MATERIAL

John D. Ray
SECTION CHIEF

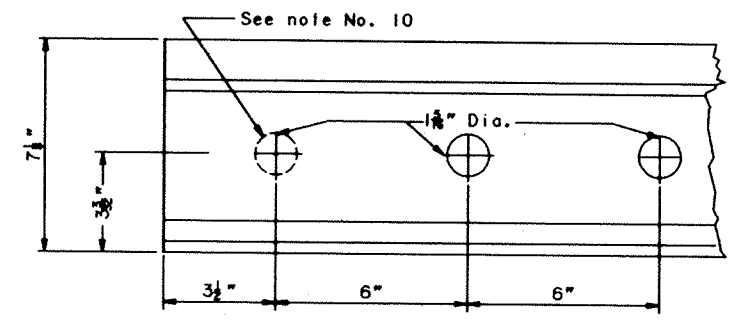
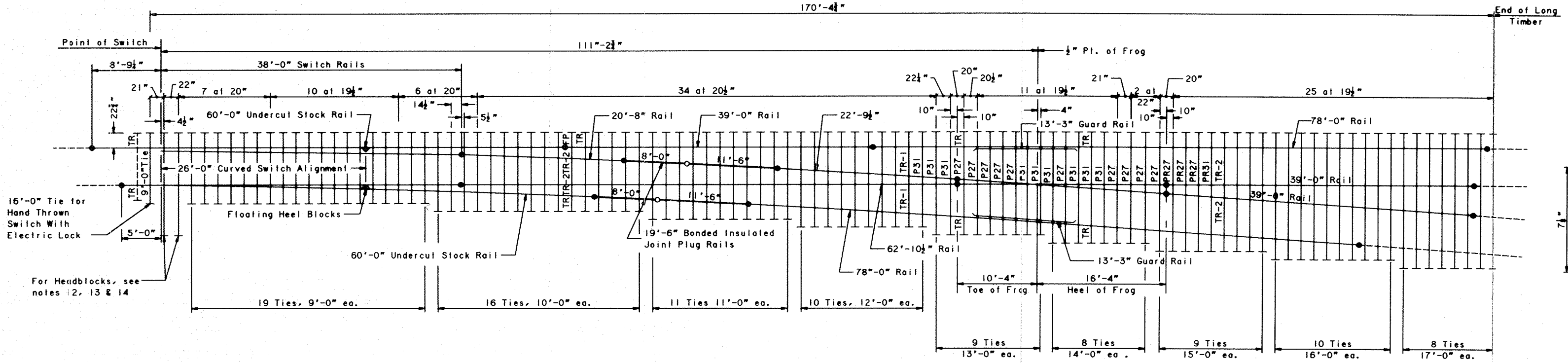

RAIL END DRILLING

LONG TIMBERS REQUIRED

Quantity	Length
20	9'-0"
16	10'-0"
11	11'-0"
10	12'-0"
9	13'-0"
8	14'-0"
9	15'-0"
10	16'-0"
8	17'-0"
101	Total

Headblocks not shown in table, see notes 12, 13 & 14.

NOTES

- 1-Stock rails, switch points and all rails furnished to be fully heal treated.
- 2-Switch points per A.R.E.A. Detail 5100 as shown on plan 2155..
- 3-60' stock rails, to be undercul as per Plan 2360.
- 4-For switch details see Plan 2165.
- 5-Gage plate No. 1 - G as per Plan 2157.
- 6-Switch plates Nos. O, I, IA, HP and IP as per Plan 2157.
- 7-Turnout plates, No. 2 thru No. 15, as per Plan 2343.
- 8-Vertical insulated switch rods and adjustable rocker clips, as per Plan 2158.
- 9-Floating Heel block as per Plan 2350.
- 10-All rails, including switch rails, to be drilled as shown on this plan, except that first hole is not to be drilled by the manufacturer. Installer to field drill first hole when necessary.
- 11-All tie plates to be resiliently fastened except guard rails.
- 12-Two 9"x10"x13' Headblocks needed with switch stand 3' high or less, 16' long with stands over 3'
- 13-Three 9"x10"x16' Headblocks needed for hand thrown switch with electric lock.
- 14-Two 9"x10"x12' Headblocks needed for power operated switch.
- 15-See Plan 2160 for Bill of Material
- 16-Rail lengths are computed to allow a 1/4" gap for temporarily bolting the field welded joints and 1/8" gap for insulated joints. When rails are welded in the field, they must be cut to provide gaps recommended by the weld kit manufacturer.
- 17-Transition Plates (TR) 1:80 Cont, and Flat Plate (FP) as per Plan 2348.

FROG TIE PLATES

- 20 - P27 SAS (self-aligning shoulder)
- 18 - P31 SAS
- 6 - PR27 SAS
- 2 - PR31 SAS

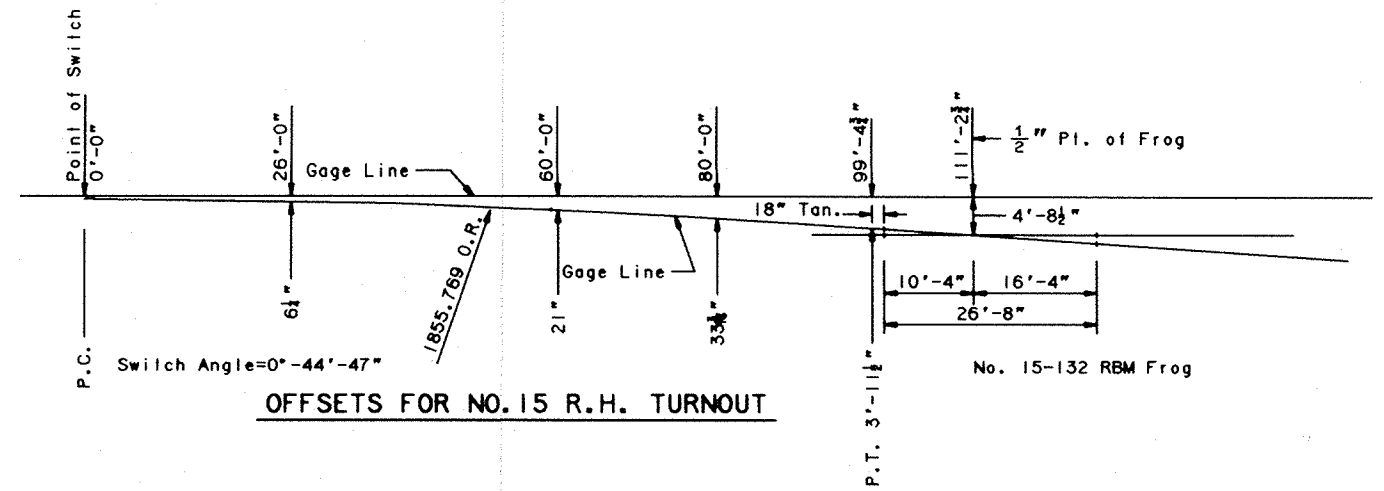

OFFSETS FOR NO. 15 R.H. TURNOUT

- LEGEND**
- Indicates rails furnished by the manufacturer.
 - - - Indicates rails furnished by the installer.
 - ▲ Indicates "floating" heel blocks.
 - Indicates insulated joints with 3/16" opening.
 - Indicates joints to be field welded.
 - Indicates Bonded Insulated Joint Plug Rail

	RAILROAD OPERATIONS	DWG. NO. 2162
		JAN. 5, 1996
NO. 15 TURNOUT WITH FLOATING HEEL BLOCKS - TIE & RAIL LAYOUT		
SECTION CHIEF		

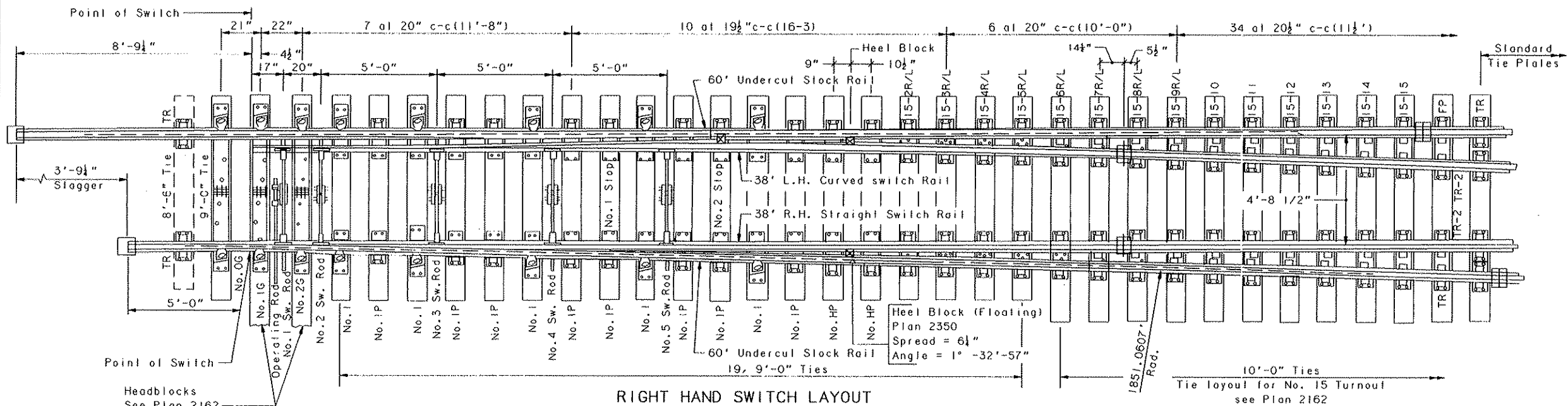

RIGHT HAND SWITCH LAYOUT

Switch Angle = 0° - 44' - 47"
Side Planing = 14' - 7" 132-RE

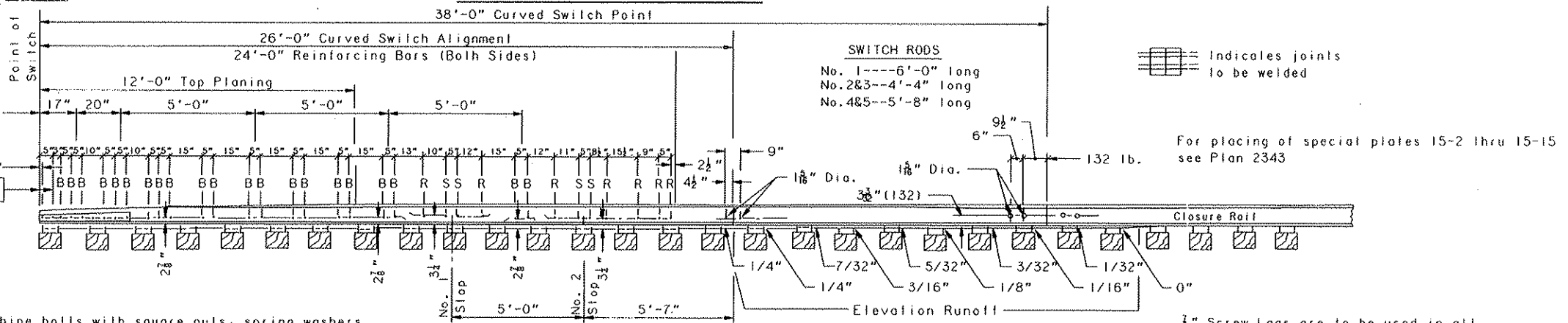

ELEVATION OF SWITCH RAIL

NOTES

- This plan for use with A.R.E.A. recommended standards for 132 R.E..
- Workmanship and materials shall be as per current A.R.E.A. Specifications.
- Gage Plates OG, IG and 2G as shown on Plan 2157.
- Switch Plates Nos. 1, IP and HP shown on Plan 2157.
- Turnout Plates No. 2 thru No. 15 as shown on Plans 2343.
- Stock Rails to be undercut as per Plan 2360.
- Switch Rails to be undercut per A.R.E.A. Design 5100.
- All rails to be Fully Heat Treated.
- Vertical insulated switch rods and adjustable rocker clips as per Plan 2158.
- All rails, including switch rails, to be drilled per Plan 2162 for 132 R.E. rail, with the first hole not to be drilled by manufacturer. Installer to field drill first hole when necessary.
- See Plan 2160 for Bill of Material.
- All bolts shall be dipped in a non-oxidizing grease immediately before applying so that all threads are thoroughly coated.

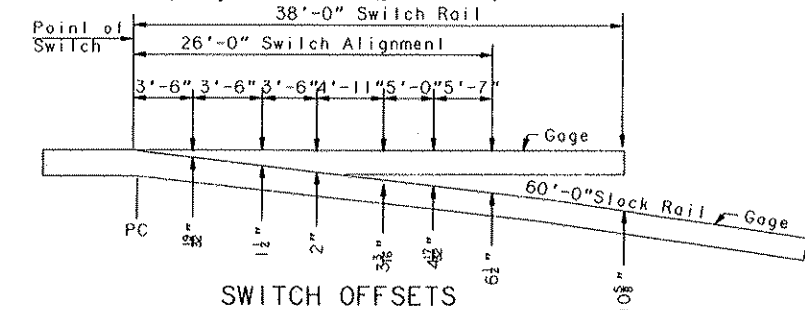

<p>MASSACHUSETTS BAY TRANSPORTATION AUTHORITY</p>	<p>RAILROAD OPERATIONS</p>	<p>DWG. NO. 2165</p>
		<p>Jan 5, 1996 ISSUE DATE</p>
<p>26' CURVED SPLIT SWITCH WITH FLOATING HEEL BLOCKS</p>		
<p><i>John D. Ray</i> SECTION CHIEF</p>		

BILL OF MATERIAL FOR A NO. 20 TURNOUT

Quantity	Description	Reference Plan No.
* 1	Pair of 39'-0" Switch Points, complete with reinforcing bars, clips and stops attached	2205
2	Heel Block Assemblies, complete	2350
* 2	39'-0" Undercut Stock Rails	2205
3	Insulated Gage Plates (Nos. 0-G, 1-G & 2-G)	2207
14	No. 1 Adjustable Brace Slide Plates	"
2	No. 3 Adjustable Brace Slide Plates	"
22	No. 1-P Shoulder Slide Plates	"
2	No. 2 Shoulder Slide Plates	"
2	No. 4 Shoulder Slide Plates	"
2	No. SH Heel Plates, 1-RH and 1-LH	"
5	Switch Rail Stops	2350
10	Adjustable Rocker Clips for Vertical Switch Rods	2208
5	Insulated Vertical Switch Rods (No. 1, 2, 3, 4 & 5)	2208
40	Turnout Plates for use behind heel of switch (No. 20-2 to 20-21 x 2)	2340
22	Resiliently Fastened Adjustable Rail Brace	2352
1	No. 20 Railbound Manganese Steel Frog, Complete	2206
2	FT20 Hook Twin Tie Plates	2326
14	FT23 " " " "	"
22	FT27 " " " "	"
4	FT29 " " " "	"
—	FT33 " " " "	"
—	FT23 Modified Hook Twin Tie Plates	"
4	FT27 " " " " "	"
—	FT29 " " " " "	"
—	FT33 " " " " "	"
2	FTR27 Hook Twin Tie Plates	"
—	FTR29 " " " "	"
2	FTR31 " " " "	"
6	FTR33 " " " "	"
—	FTR27 Modified Hook Twin Tie Plates	"
4	FTR29 " " " " "	"
—	FTR31 " " " " "	"

* These items shall be supplied for R.H., L.H. or Equilateral Turnout as required.

Quantity	Description	Reference Plan No.
—	FTR33 Modified Hook Twin Tie Plates	2326
2	13'-3" Manganese Steel One Piece Guard Rails	2302
—	Bonded Insulated Joint Assembly	—
2	39'-0" Bonded Insulated Joint Plug Rail	1340
12	39'-0" Lengths of Fully Heat Treated Rail	—
1 ea. †	Various Lengths of Fully Heat Treated Rail as follows: 34'-0", 29'-6", 24'-5", 24'-5 3/16"	—
1966	7" Lock Spikes	1216
140	5/8 x 6" AREA Spikes **	1210
967	Resilient Fastener Spring Clips - Type "E"	—
16	Resilient Fastener Spring Clips - Type Modified "E"	—
396	Standard Resilient Fastener Tie Plates	1224
2	Pairs of Modified Joint Bar Assemblies (Head & Toe of Gage Side Bars Removed to Allow Switch Movement at Joint near Heel of Switch - No. 20 only)	2202
1	Mechanism for Bell Crank Helper, Complete	2209
22	Standard Joint Bar Assemblies	1322 or 1320
88	Standard Track Bolts with Nuts and Washers	1332

** Cut Spikes are to be furnished by the installer.

Weld Kits (24) to be furnished by the installer.

† For Equilateral Turnout, closure rails have slightly different lengths. See Equilateral Drawing (2203).

- Notes:**
1. Turnouts supplied shall be either 115 or 132 L.B. RE as specified in the order.
 2. Turnouts shall be resiliently fastened throughout, except Frog Tie Plates, Guard Rails and locations where Spring Clips cannot be physically installed such as on turnout plates near heel.
 3. Fabricator shall supply all material required for the complete installation of the turnout except switch timber unless otherwise specified in the order.
 4. For Switch Timber Schedule, see Plan 2202.

T	MASSACHUSETTS BAY TRANSPORTATION AUTHORITY	RAILROAD OPERATIONS	DWG. NO. 2200
			Apr. 29, 1996 ISSUE DATE
		NO. 20 TURNOUT BILL OF MATERIAL	(3) ISSUE NO.
<i>John D. Ray</i>		<i>W. A. ...</i>	
ENGINEERING OFFICER		CHIEF ENGINEERING OFFICER	

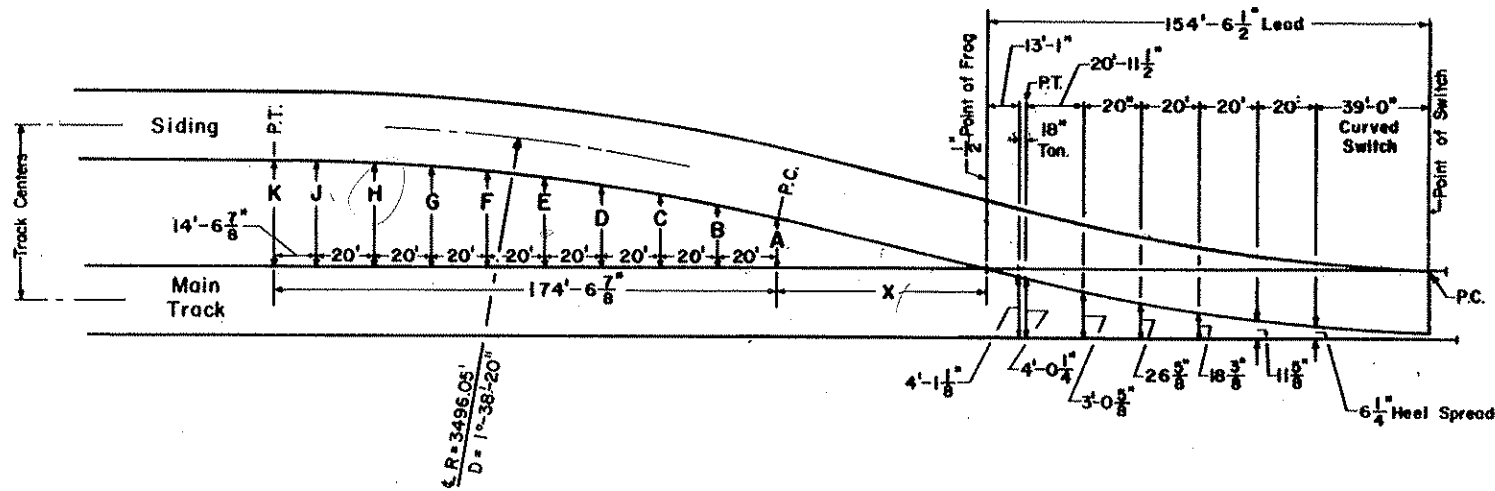

TURNOUT DATA FOR BOLTED TRACK

FROG--R.B.M.

Number	-----	20
Angle	-----	2°-51'-51"
Toe Length	-----	13'-1"
Heel Length	-----	21'-1"
Total Length	-----	34'-2"

SWITCH RAILS

Length	-----	39'-0"
Type	-----	Curved
Switch Angle For Undercut Points	-----	0°-25'-32"
Heel Block Angle	-----	1°-06'-17"
Point of Curve (P.C.)	-----	At Switch Point

LEAD

Point of Switch to 1/2" Point of Frog	-----	154'-6 1/2"
Radius	-----	3289.332'
Degree of Curve	-----	1°-44'-30" <i>9617</i>
Length of Curved Closure Rail	-----	102'-6 1/2"
Length of Straight Closure Rail	-----	102'-5 1/2"

OFFSETS BEHIND THE HEEL OF FROG

TRACK CENTERS	X	A	B	C	D	E	F	G	H	J	K
12'-2"	61'-0 1/8"	3'-1 1/8"	4'-0 1/2"	4'-10 3/8"	5'-7"	6'-2 1/8"	6'-8"	7'-0 3/8"	7'-3 1/2"	7'-5 1/8"	7'-5 1/2"
12'-4"	64'-4 1/8"	3'-3 3/8"	4'-2 1/2"	5'-0 3/8"	5'-9"	6'-4 1/8"	6'-10"	7'-2 3/8"	7'-5 1/2"	7'-7 1/8"	7'-7 1/2"
12'-6"	67'-8 1/8"	3'-5 1/8"	4'-4 1/2"	5'-2 3/8"	5'-11"	6'-6 1/8"	7'-0"	7'-4 3/8"	7'-7 1/2"	7'-9 1/8"	7'-9 1/2"
12'-8"	71'-0 1/4"	3'-7 1/8"	4'-6 1/2"	5'-4 3/8"	6'-1"	6'-8 1/8"	7'-2"	7'-6 3/8"	7'-9 1/2"	7'-11 1/8"	7'-11 1/2"
12'-10"	74'-4"	3'-9 1/8"	4'-8 1/2"	5'-6 3/8"	6'-3"	6'-10 1/8"	7'-4"	7'-8 3/8"	7'-11 1/2"	8'-1 1/8"	8'-1 1/2"
13'-0"	77'-8"	3'-11 1/8"	4'-10 1/2"	5'-8 3/8"	6'-5"	7'-0 1/8"	7'-6"	7'-10 3/8"	8'-1 1/2"	8'-3 1/8"	8'-3 1/2"
13'-2"	80'-11 7/8"	4'-1 1/8"	5'-0 1/2"	5'-10 3/8"	6'-7"	7'-2 1/8"	7'-8"	8'-0 3/8"	8'-3 1/2"	8'-5 1/8"	8'-5 1/2"
13'-4"	84'-3 7/8"	4'-3 1/8"	5'-2 1/2"	6'-0 3/8"	6'-9"	7'-4 1/8"	7'-10"	8'-2 3/8"	8'-5 1/2"	8'-7 1/8"	8'-7 1/2"
13'-6"	87'-8"	4'-5 1/8"	5'-4 1/2"	6'-2 3/8"	6'-11"	7'-6 1/8"	8'-0"	8'-4 3/8"	8'-7 1/2"	8'-9 1/8"	8'-9 1/2"

Values for track centers not shown may be determined by interpolation.

NOTES

- The lines of the diagram indicate gage lines.
- For details see the following plans:--
Switch- 2205 or 2215
Frog-R.B.M. 2206
- For welded turnouts see Plan 2202 or 2212 for offsets between the point of switch and the toe of frog.

T	MASSACHUSETTS BAY TRANSPORTATION AUTHORITY	RAILROAD OPERATIONS	DWG. NO. 2201
			Oct. 28, 1992 ISSUE DATE
OFFSETS FOR NO. 20 TURNOUT 115 OR 132 R.E. RAIL-UNDERCUT		<i>John D. Ray</i> ENGINEERING OFFICER	<i>W. A. ...</i> CHIEF ENGINEERING OFFICER

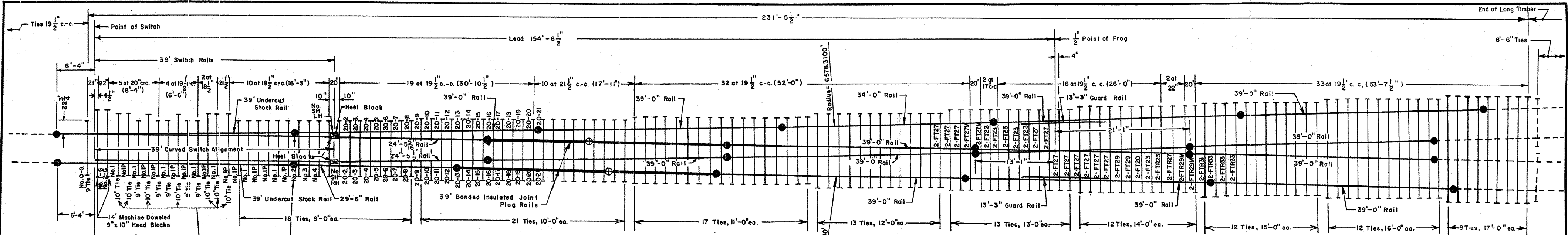

NOTES

- 1- Stock rails, switch rails and all rail furnished with the turnout to be fully heat treated.
- 2- Switch Points per A.R.E.A. Detail 5100 as shown on dwg. 2205.
- 3- 39' stock rails are to be undercut as shown on this plan.
- 4- Gage plates O-G, I-G and 2-G as per plan 2207.
- 5- Switch plates Nos. 1 and I-P as per plan 2207.
- 6- For turnout plates behind heel, see Plan 2340.
- 7- Vertical insulated switch rods and adjustable rocker clips generally as per plan 2208.
- 8- Heel blocks as per Plan 2350.
- 9- For switch details, see Plan 2205, modified as indicated for an equilateral.
- 10- All rails, including switch rails, to be drilled as shown on this sheet except that the first hole is not to be drilled by the manufacturer. MBTA forces to field drill first hole when necessary.
- 11- See Plan 2200 for bill of materials.
- 12- All tie plates to be resiliently fastened, except frog tie plates and guard rails.
- 13- Rail lengths are computed to allow a $\frac{1}{8}$ " gap for temporarily bolting the field welded joints and $\frac{3}{16}$ " gap for insulated joints. When rails are welded in the field, they must be cut to allow gaps recommended by the weld kit manufacturer.

Provide 2 Modified Joint Bar Assemblies for Temporary Field Connection

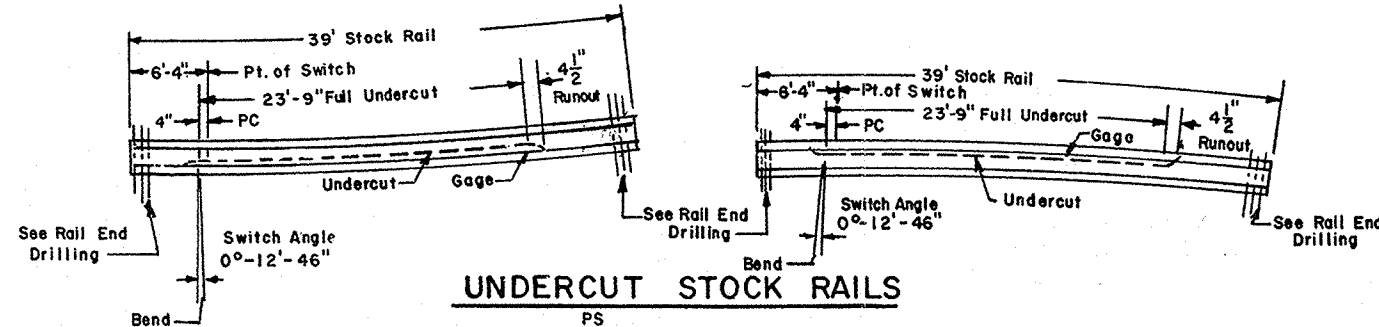

UNDERCUT STOCK RAILS

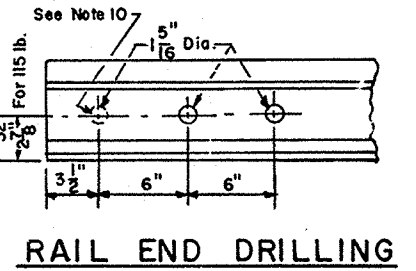

LEGEND

- Indicates rails furnished by the manufacturer.
- - - - - Indicates rails furnished by the installer
- ⊕ Indicates insulated joints with $\frac{3}{16}$ " Opening
- Indicates field welded joints
- Indicates Factory Assembled Bonded Insulated Joint Plug Rails furnished by the manufacturer.

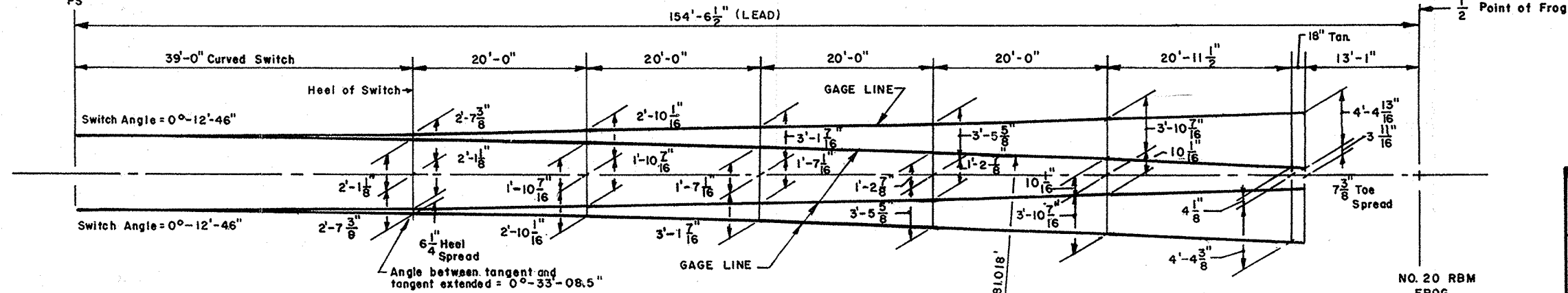

OFFSETS FOR NO. 20 EQUILATERAL TURNOUT

ALL OFFSETS SHOWN ARE TO GAGE LINES

	RAILROAD OPERATIONS	DWG. NO. 2203
	MASSACHUSETTS BAY TRANSPORTATION AUTHORITY	Apr. 29, 1992 ISSUE DATE
NO. 20 EQUILATERAL TURNOUT TIE AND RAIL LAYOUT		
SECTION CHIEF		

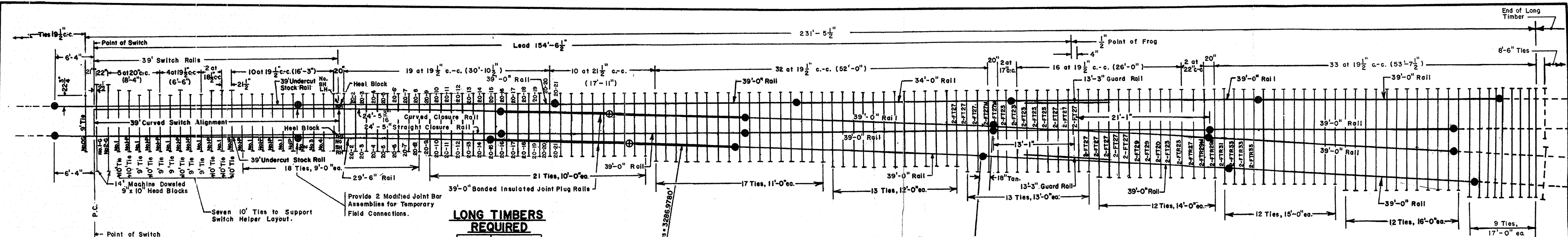

NOTES

- 1 - Stock rails and switch points and all rails furnished with the turnout are to be fully heat treated.
- 2 - Switch Points per A.R.E.A. Detail 5100 as shown on plan 2205.
- 3 - 39' stock rails, are to be undercut as per Plan 2205
- 4 - Gage plates O-G, I-G and 2-G as per Plan 2207
- 5 - Switch plates Nos. 1 and I-P as per Plan 2207
- 6 - For turnout plates behind heel, see Plan 2340.
- 7 - Vertical insulated switch rods and adjustable rocker clips generally as per Plan 2208
- 8 - Heel Blocks as per Plan 2350
- 9 - For switch details see Plan 2205.
- 10 - All rails, including switch rails, to be drilled as shown on this sheet, except that first hole is not to be drilled by the manufacturer. Forces, designated by the Authority, are to drill the first hole when necessary.
- 11 - All tie plates to be resiliently fastened, except, frog tie plates and guard rails.
- 12 - See Plan 2200 for Bill of Materials.
- 13 - Rail lengths are computed to allow a 1/8" gap for temporarily bolting the field welded joints and 3/16" gap for insulated joints. When rails are welded in the field, they must be cut to provide gaps recommended by the weld kit manufacturer.

LONG TIMBERS REQUIRED

QUANTITY	LENGTH
24	9'-0"
28	10'-0"
17	11'-0"
13	12'-0"
13	13'-0"
14 *	14'-0"
12	15'-0"
12	16'-0"
9	17'-0"
142	Total

* Includes 2 - 9"x10" Head Blocks

FROG TIE PLATES REQUIRED

- 2 - FT 20
- 14 - FT 23
- 22 - FT 27
- 4 - FT 27 Modified
- 4 - FT 29
- 2 - FTR 27
- 4 - FTR 29 Modified
- 2 - FTR 31
- 6 - FTR 33
- 60 Total

Plan 2326

LEGEND

- Indicates rails furnished by the manufacturer.
- - - Indicates rails furnished by the installer
- Indicates factory assembled bonded insulated joint plug rails furnished by the manufacturer.
- ⊕ Indicates insulated joints with 3/16" opening.
- Indicates field welded joints.

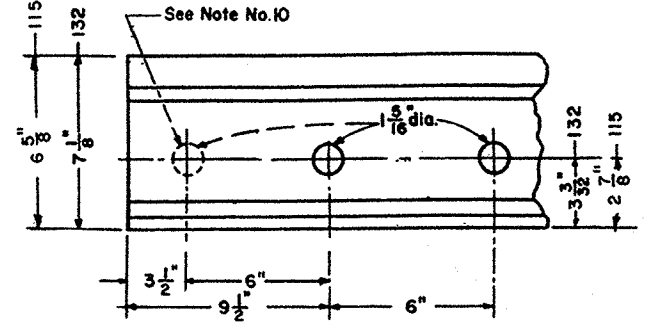

RAIL END DRILLING

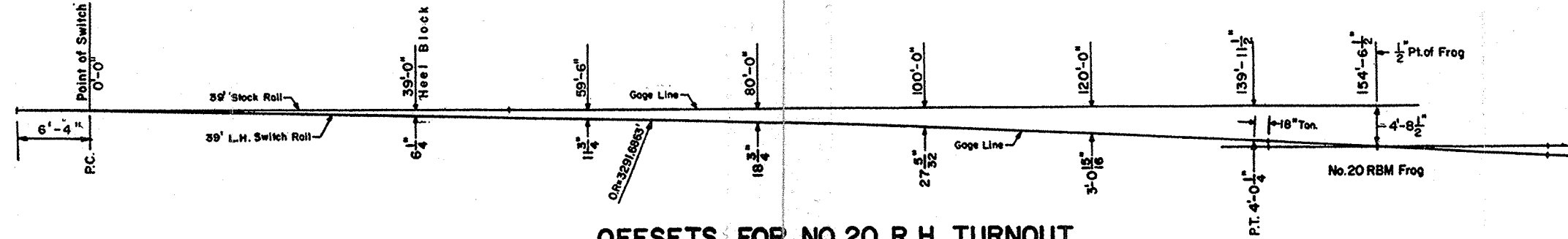

OFFSETS FOR NO. 20 R.H. TURNOUT

	RAILROAD OPERATIONS	DWG. NO. 2202 Apr. 29, 1996 ISSUE DATE
	NO. 20 WELDED TURNOUT TIE AND RAIL LAYOUT <i>John D. Ray</i> SECTION CHIEF	

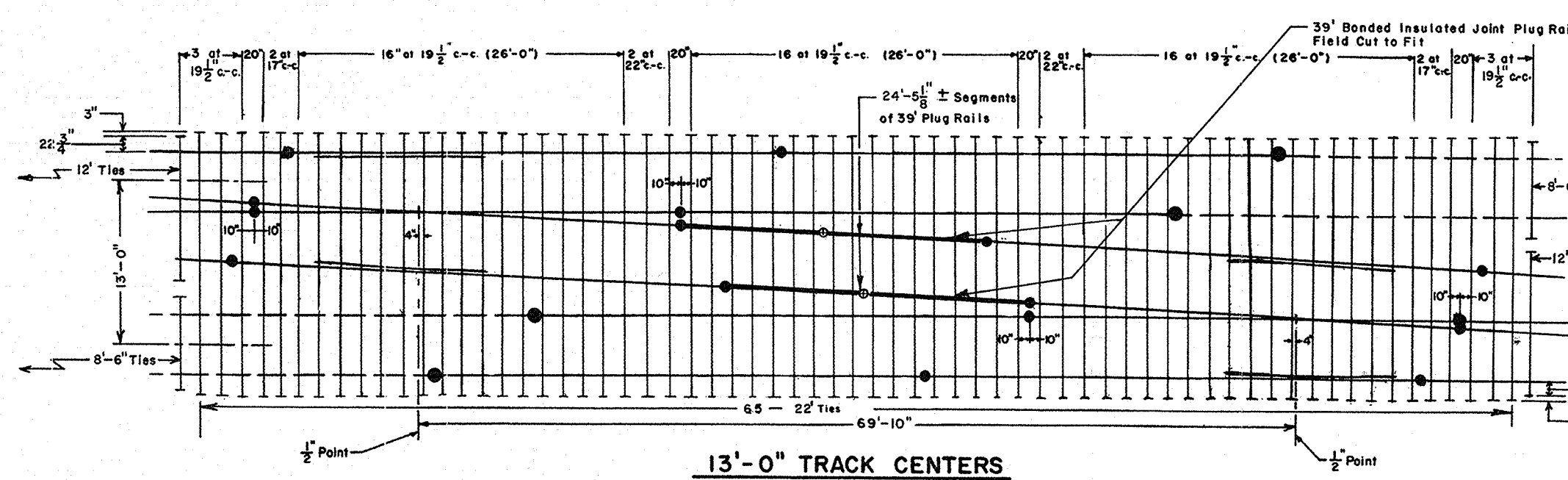

13'-0" TRACK CENTERS

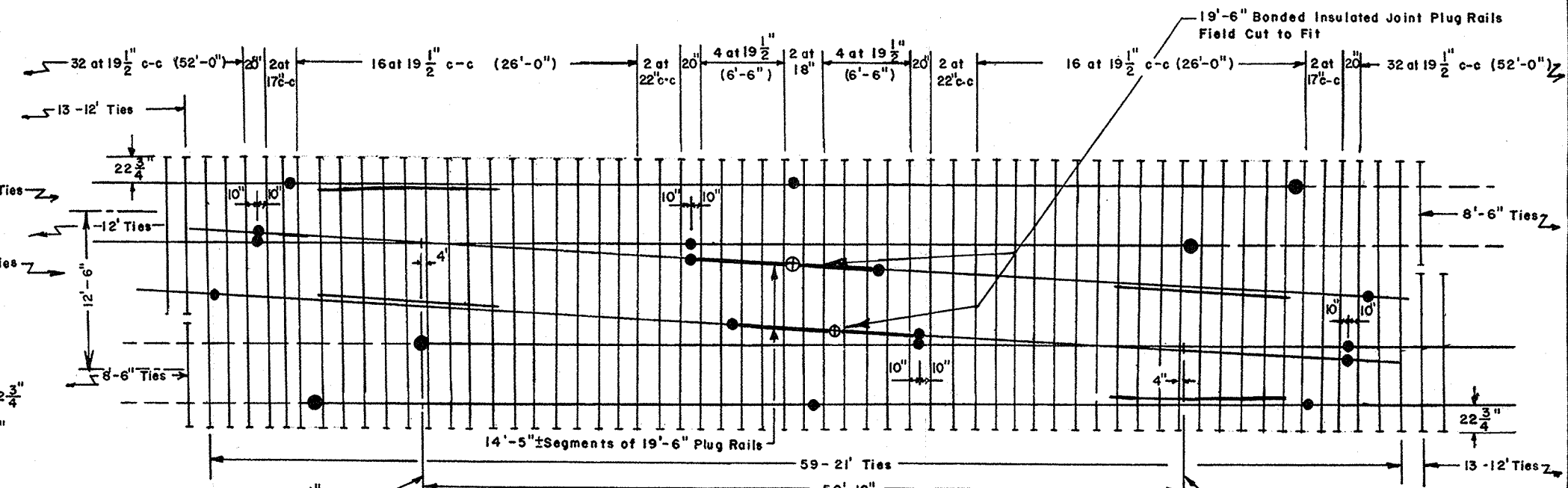

12'-6" TRACK CENTERS

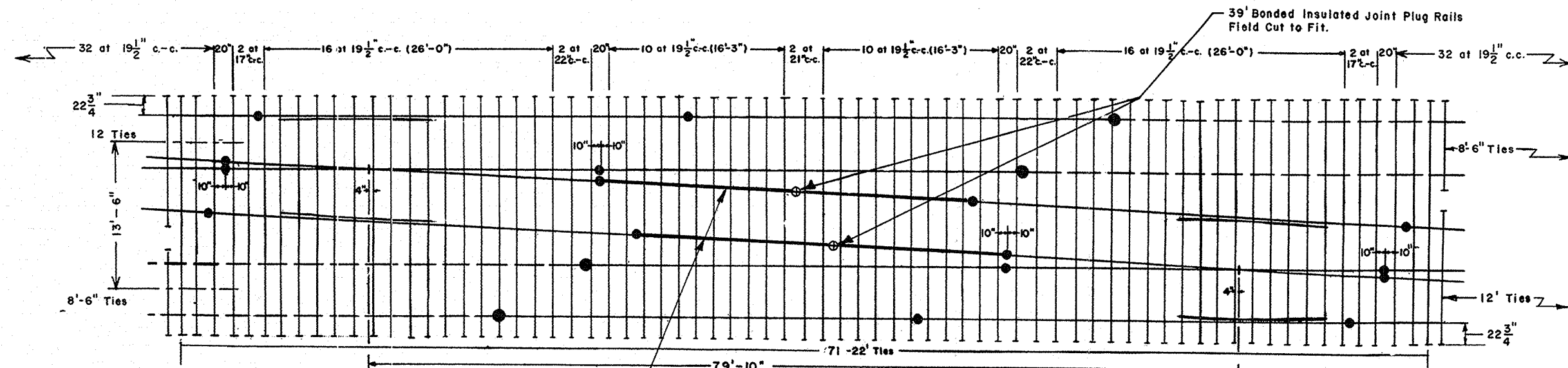

13'-6" TRACK CENTERS

Rails shown dashed are not furnished with the turnouts and shall be supplied by the installer

Frog Angle = 2°-51'-51"
 Toe Length = 13'-1"
 Heel Length = 21'-1"
 Total Length = 34'-2"

For turnout see Dwg. 2202 or 2212 for floating heel block type turnout.

For every 1" change in track centers, the horizontal distance between 1/2" frog points will increase 20."

SWITCH TIMBER FOR A CROSSOVER

TRACK CENTERS	TIMBER LENGTHS							
	9'-0"	10'-0"	11'-0"	12'-0"	13'-0"	14'-0"	21'-0"	22'-0"
12'-6"	48	56	34	26	—	4	59	—
13'-0"	48	56	34	26	—	4	—	65
13'-6"	48	56	34	26	—	4	—	71

(44) (58) (32) (28) Figures in parenthesis are for floating heel block type turnouts.
 Includes 4 headblock ties - 9" x 10"

NOTE: Timber layout shown is for exact track centers indicated. Other track centers require adjusting the timber schedule and timber spacing as required.

MASSACHUSETTS BAY TRANSPORTATION AUTHORITY RAILROAD OPERATIONS
 DWG. NO. 2204
 Apr. 29, 1996
 SECTION CHIEF

NO. 20 CROSSOVER TIE AND RAIL LAYOUT

John D. Ray
 SECTION CHIEF

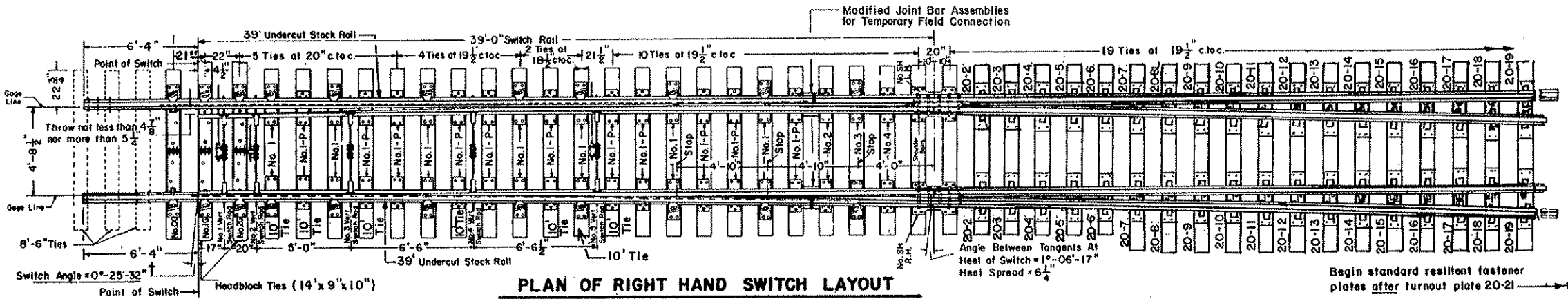

PLAN OF RIGHT HAND SWITCH LAYOUT

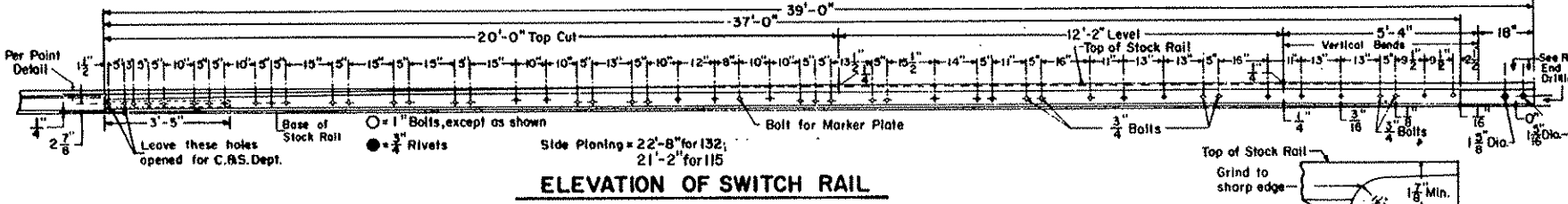

ELEVATION OF SWITCH RAIL

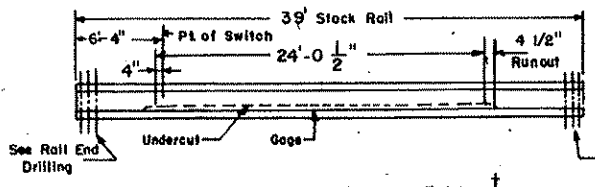

STRAIGHT STOCK RAIL

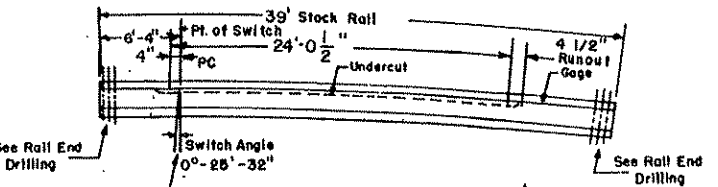

CURVED STOCK RAIL

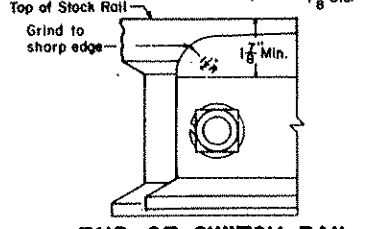

END OF SWITCH RAIL

TURNOUT INFORMATION

OFFSETS - Plan 2201

TIE and RAIL LAYOUT

Plan 2202

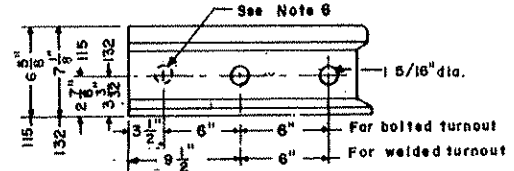

RAIL END DRILLING

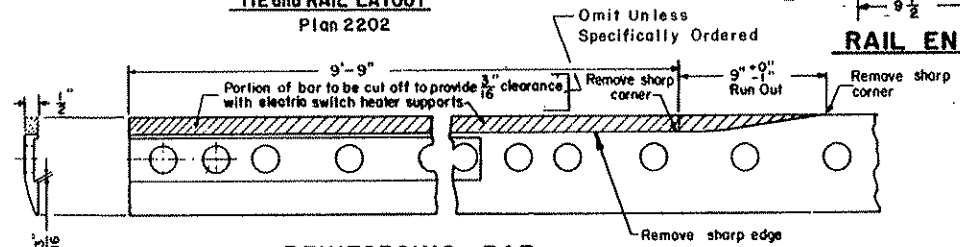

REINFORCING BAR

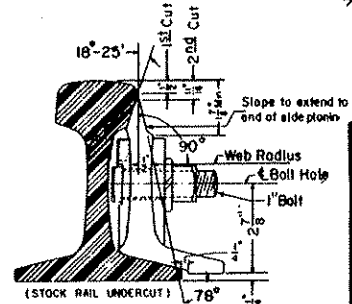

SWITCH POINT DETAIL

BILL OF MATERIAL

- * 1 - Pair 39'-0" Switch Points, 1-R.H. straight and 1-L.H. curved, complete with reinforcing bars, clips and stops attached.
- 2 - 39'-0" Undercut Stock Rails.
- 5 - Insulated Vertical Switch Rods, 2 with baskets - Plan 2208.
- 2 - Heel Block assemblies, complete - Plan 2350.
- 3 - Insulated Gage Plates Nos. O-G, I-G B2-G.
- 14 - No. 1 Adjustable Brace Slide Plates
 - 2 - No. 3 " " " "
 - 22 - No. 1-P Shoulder Slide Plates
 - 2 - No. 2 " " " "
 - 2 - No. 4 " " " "
 - 2 - No. SH Heel Plates, 1-R.H. and 1-L.H.
 - 5 - Switch Rail Stops.
 - 10 - Adjustable Rocker Clips for vertical switch rods - Plan 2208.
 - 40 - Turnout Pocket Plates with welded pressed steel shoulders for resilient fasteners - Plan 2340.
 - 22 - Resiliently fastened Adjustable Rail Braces - Plan 2352.
 - 4 - (two pairs) Modified Joint Bar Assemblies.

NOTES

- 1 - This plan is for use with A.R.E.A. recommended standards for 115 or 132 R.E. rail.
- 2 - All rail to be fully heat treated.
- † 3 - For stock rails, switch angles and offsets for an equilateral, see Plan 2205.
- 4 - All bolts shall be dipped immediately before applying (so that threads are thoroughly coated) in grease
- * 5 - When ordering a Left Hand Switch, these items shall be opposite hand.
- † 6 - For bolted turnouts, the first bolt hole is to be drilled in the field.

T	MASSACHUSETTS BAY TRANSPORTATION AUTHORITY	RAILROAD OPERATIONS	DWG. NO. 2205 Apr. 29, 1996 ISSUE DATE	(3) ISSUE NO.
	SECTION CHIEF			

39'-0" CURVED SPLIT SWITCH
115 OR 132 R.E. RAIL - INSULATED & UNDERCUT

John D. Ray

SECTION CHIEF

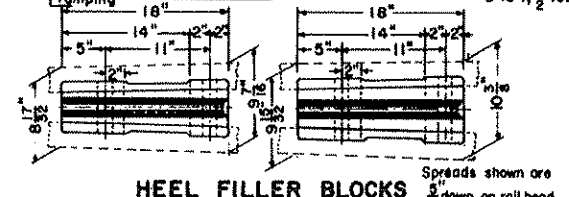
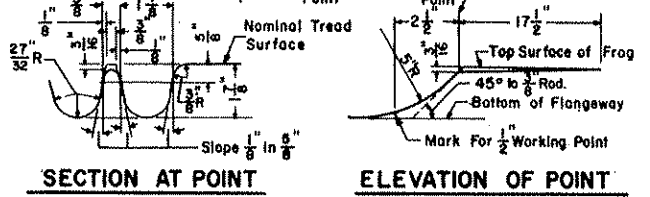
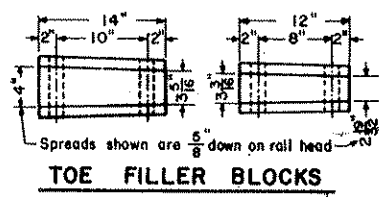
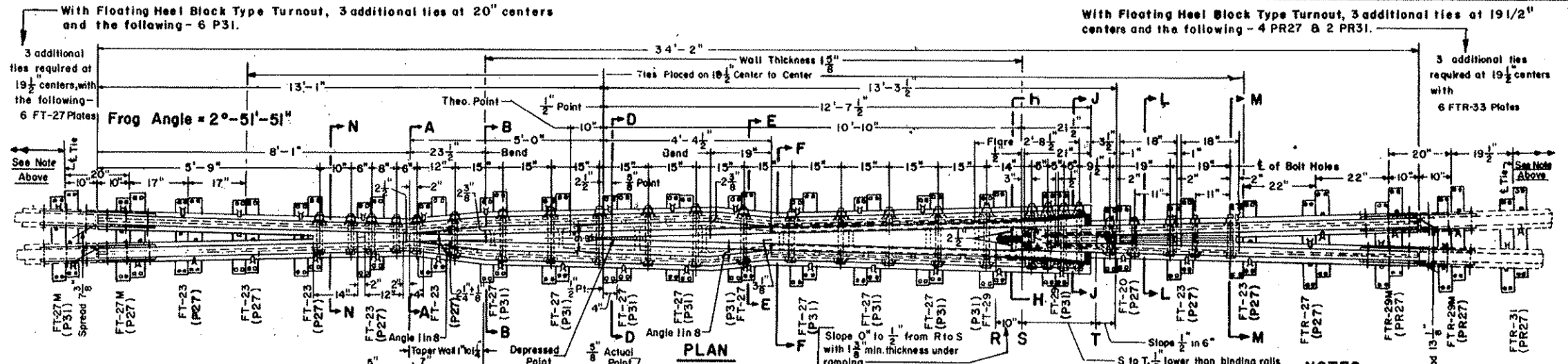

- NOTES**
- 1- This plan is for use with A.R.E.A. recommended standards for 132lb. or 115lb. R.E. Rail, heavy wall section
 - 2- Workmanship and materials shall be per current "A.R.E.A." Specifications
 - 3- Groove for bond wires shall extend from end of filler block at least to center line of second bolt hole.
 - 4- All bolts used in construction of frog and switch material shall be dipped immediately before applying (so that all threads are thoroughly coated) in grease manufactured for this purpose.
 - 5- When frog is to be used in bolted track, the first bolt hole to be drilled in the field by the installer.
 - 6- Casting to be explosion hardened, with toe and heel arms to be fully heat treated rails.
 - 7- Furnish SAS Plates unless otherwise Specified.

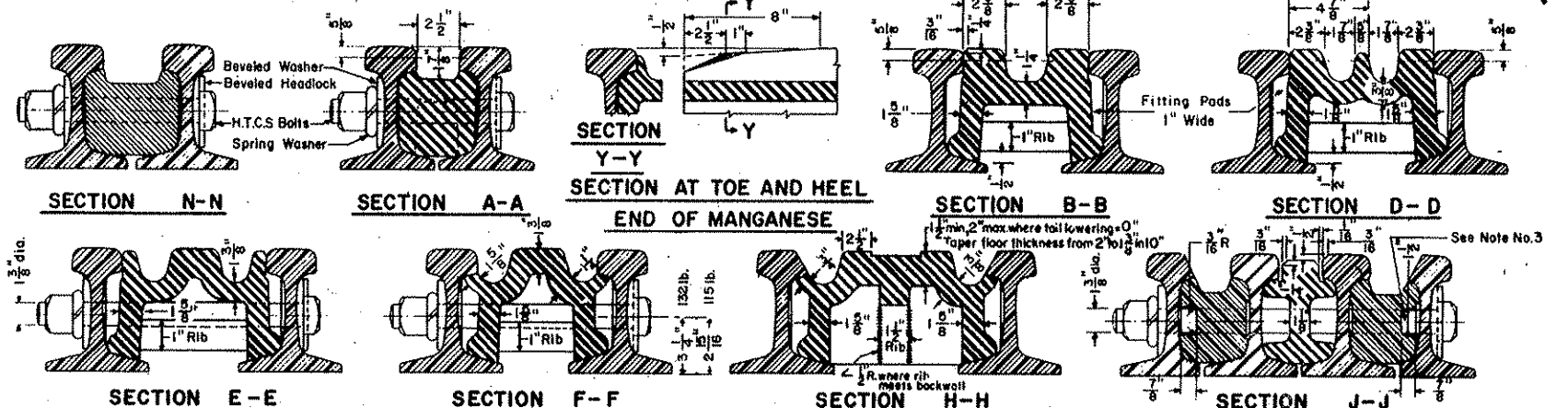

FROG TIE PLATES REQUIRED

2 - FT 20	2 - FTR27	
14 - FT 23	4 - FTR29 Modified	Plan 2326
22 - FT 27	2 - FTR31	
4 - FT 27 Modified	6 - FTR33	
4 - FT 29		or (See Note 7)
20 - P27 SAS (Self Adjusting Shoulder)		
28 - P31 SAS		Plan 2328
10 - PR27 SAS		
2 - PR31 SAS		

MASSACHUSETTS BAY TRANSPORTATION AUTHORITY	RAILROAD OPERATIONS	DWG. NO. 2206
		Jan. 5, 1996 ISSUE DATE
No. 20 RAILBOUND MANGANESE STEEL FROG FOR 115 LB. OR 132 LB. R.E. RAIL		
<i>John D. Ray</i> SECTION CHIEF		

Mark Plate and Switch Designation and Rail Section on Both Ends
 OG - 26 or 39-132
 1G - 39-132
 2G - 39-132
 (See Note No.4)

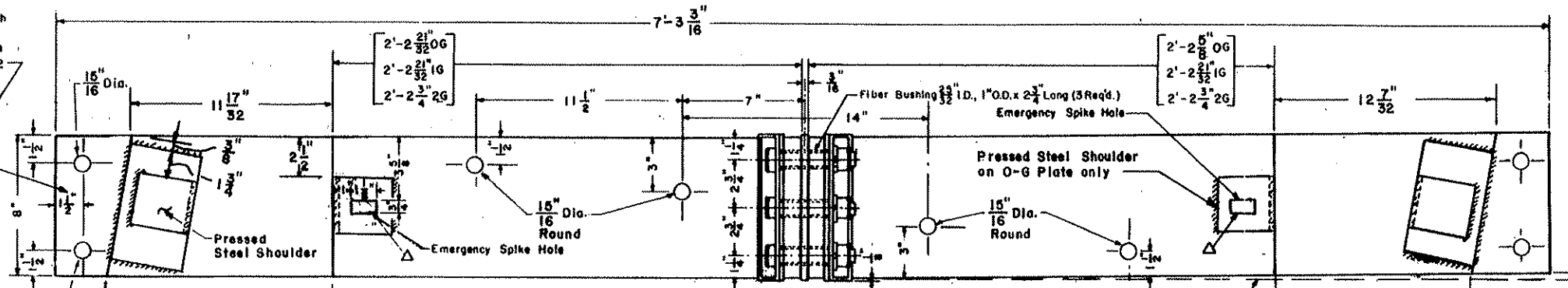

TYPICAL ALL WELDS

Full Penetration Groove Welds on Pressed Steel Shoulders
 Full Penetration Fillet Welds on R.S. Stops
 (See Note 5)

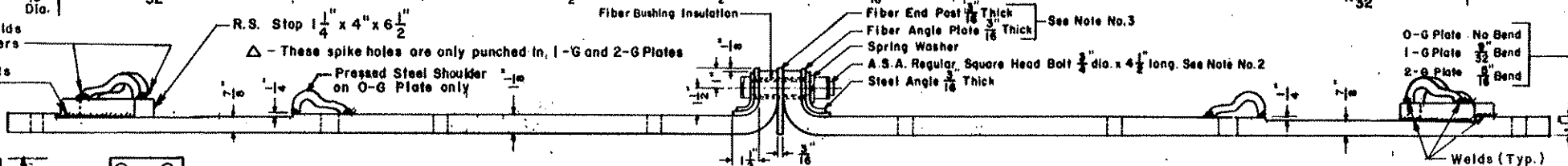

NO. 0-G, NO. 1-G & NO. 2-G INSULATED GAGE PLATES

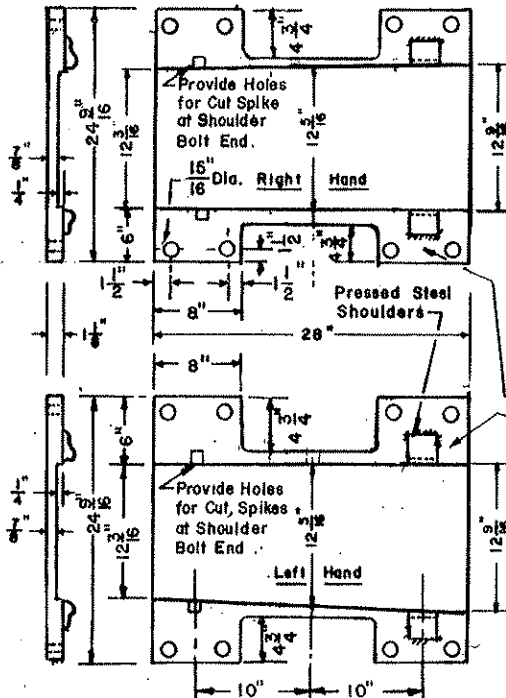

NO. SH (R.H. & L.H.) HEEL PLATES

Mark Plate Designation and Rail Section
 1-P-132
 2-132
 4-132
 (See Note No.4)

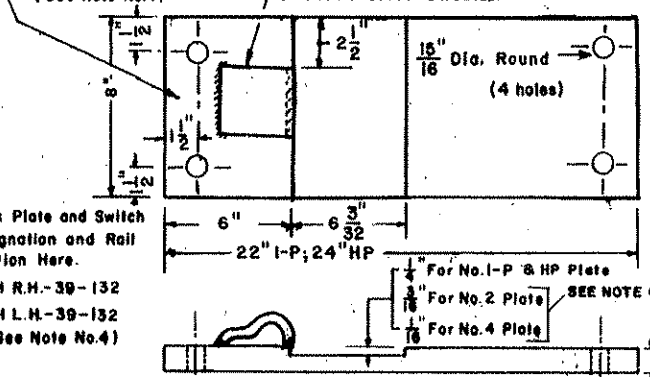

NO. 1-P, NO. 2, NO. 4 & NO. HP SHOULDER SLIDE PLATES

- NOTES:**
- 1 - Switch Plates shall conform to current A.R.E.A. Specifications for Low-Carbon Steel Tie Plates, with copper.
 - 2 - All gage plate bolts shall have A.S.A. Regular square heads and A.S.A. Heavy square nuts. All bolts shall be carbon-steel with medium-carbon steel nuts and conform to current A.R.E.A. "Specifications for Heat-Treated Carbon-Steel Track Bolts and Carbon Steel Nuts."
 - 3 - All fiber parts shall conform to current A.A.R. Signal Section Manual, Part 58, Specification No. 13 for "Hard Fiber" and A.A.R. Signal Section Manual, Part No. 178 covering "Requisites for Fabricated Fiber Parts for Track Insulation."
 - 4 - Each plate shall be marked by deeply cut characters, not less than 1/2" high, in the position as indicated on this plan.
 - 5 - Welds shall be made so that they do not interfere with the installation of resilient fasteners and rail braces.
 - 6 - Modify contour of pressed steel shoulders or shim plates 2, 3 & 4 to maintain uniform toe pressure from the resilient fasteners.

Mark Plate Designation and Rail Section Here.
 1-132
 3-132
 (See Note No.4)

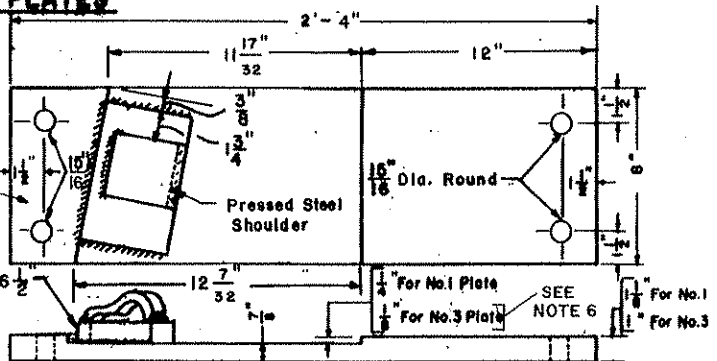

NO. 1 & NO. 3 ADJUSTABLE BRACE SLIDE PLATES

7 - For adjustable brace used with these plates, see Dwg. No. 2352

T MASSACHUSETTS BAY TRANSPORTATION AUTHORITY	RAILROAD OPERATIONS	DWG. NO. 2207
		Oct. 28, 1992 ISSUE DATE
SWITCH PLATES and GAGE PLATES FOR 39'-0" SWITCH-132 LB RAIL		
John D. Ray ENGINEERING OFFICER	W. A. R. [Signature] CHIEF ENGINEERING OFFICER	

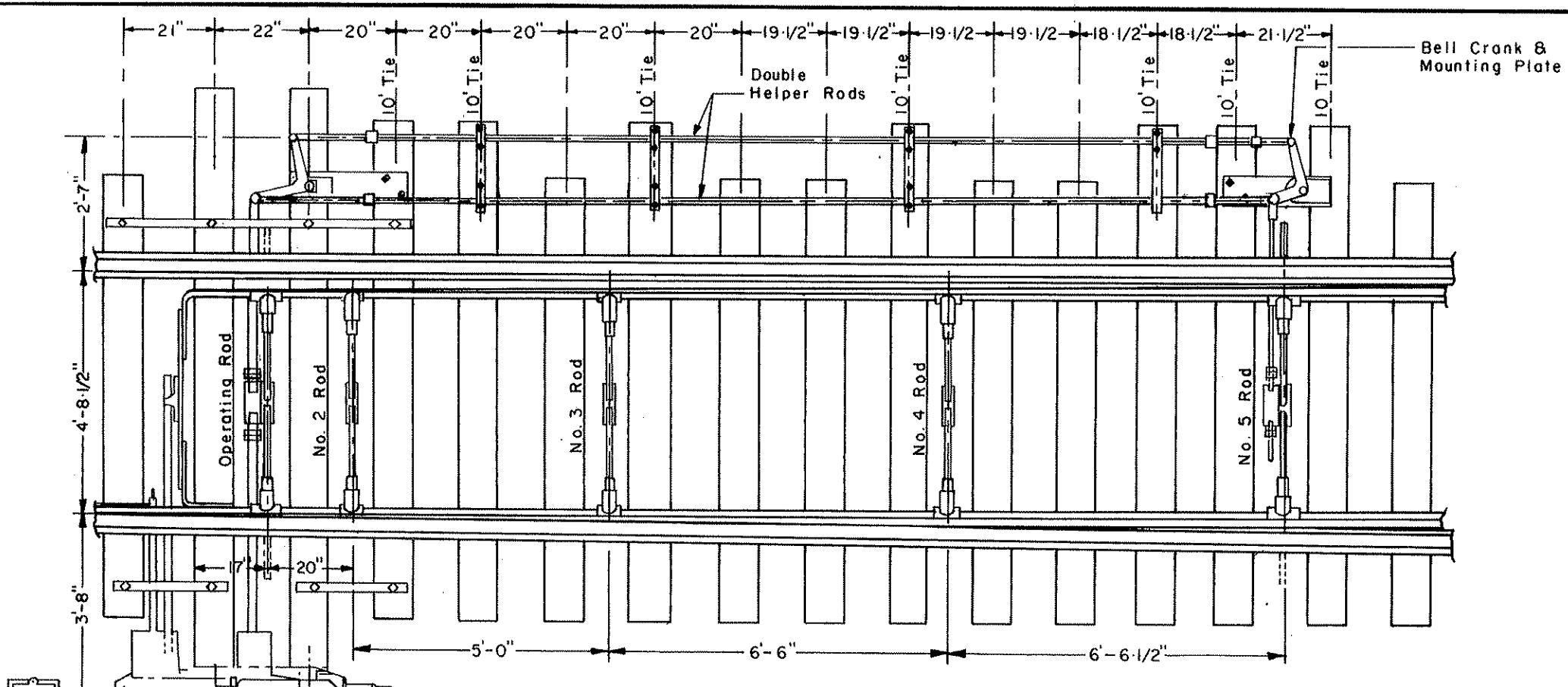

TYPICAL RIGHT HAND LAYOUT

NOTE:

Helper layout is used only with 39'-0" switch (No. 20 Turnout)

9"x10"x14'-0" Headblocks (see Dwg. No. 1110)

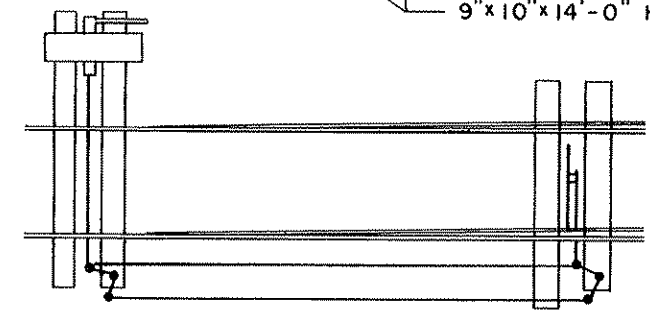

TYPICAL LEFT HAND LAYOUT

T	MASSACHUSETTS BAY TRANSPORTATION AUTHORITY	RAILROAD OPERATIONS	DWG. NO. 2209
			Apr. 29, 1996 3
		ISSUE DATE	ISSUE NO.
TYPICAL POWER SWITCH LAYOUT WITH HELPER			
<i>John D. Ray</i>			
SECTION CHIEF			

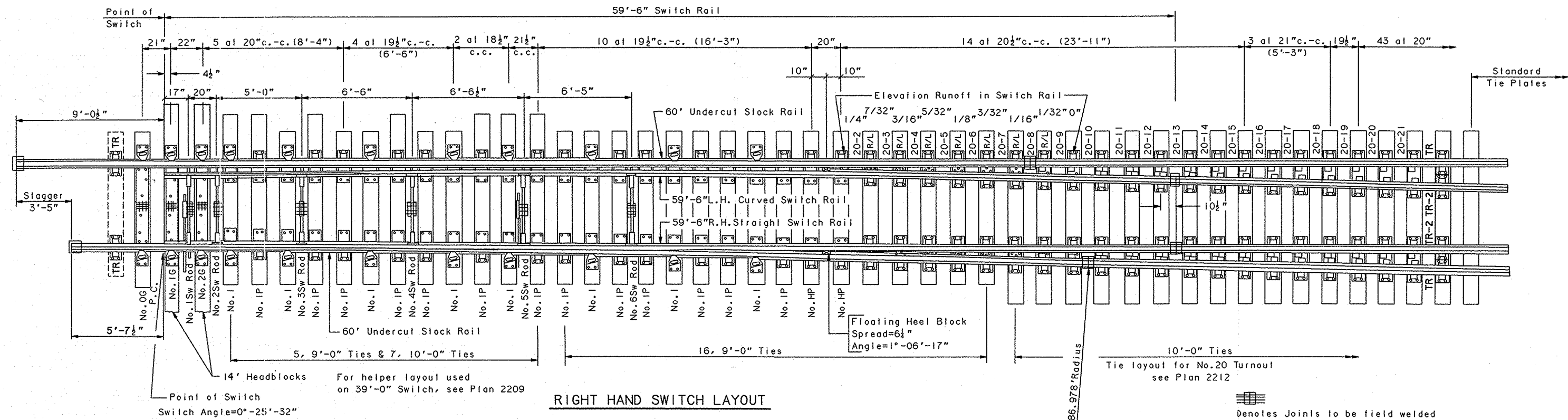

RIGHT HAND SWITCH LAYOUT

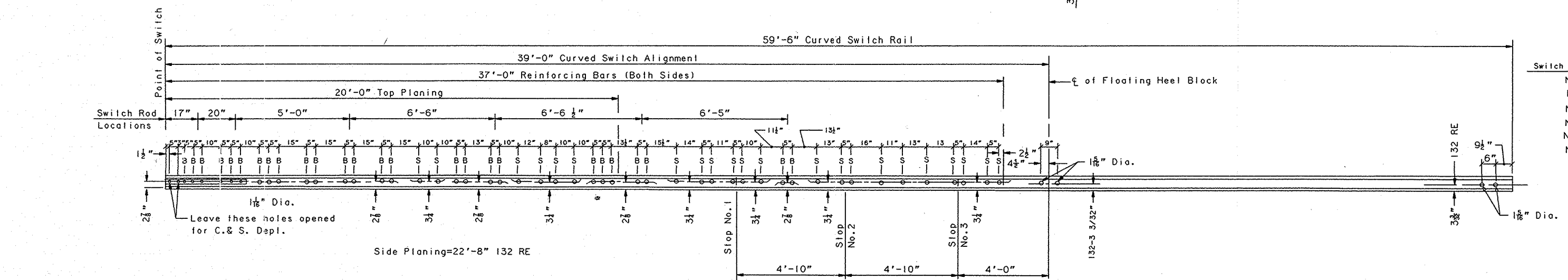

ELEVATION OF SWITCH RAIL

"B"=1" Dia. H.T. machine bolts with square nuts, spring washers and 1/4" cotter pins. Hex nuts at rocker clips.
 "S"=3/4" machine bolts for stops with square nuts, spring washers and 1/8" cotter pins.

NOTES

- This plan is for use with A.R.E.A. recommended standards for 132 RE
- Workmanship and materials shall be per current A.R.E.A. Specifications.
- Gage Plates 0-G, 1-G and 2-G as shown on Plan 2207.
- Switch Plates No. 1, No. 1p and No. HP as shown on Plan 2207.
- Turnout Plates No. 2 thru No. 21 as shown on Plan 2343.
- Stock Rails to be undercut as shown on Plan 2360.
- Switch Rails to be undercut per A.R.E.A. Design 5100.
- All rails to be Fully Heat Treated.
- Vertical insulated switch rods and adjustable rocker clips as per Plan 2208.
- All rails, including switch rails, to be drilled by the manufacturer, except first hole to be left blank. Installer to drill first hole when necessary.
- See Plan 2110 for Bill of Material.
- All bolts shall be dipped in a non-oxidizing grease immediately before applying so that all threads are thoroughly coated.

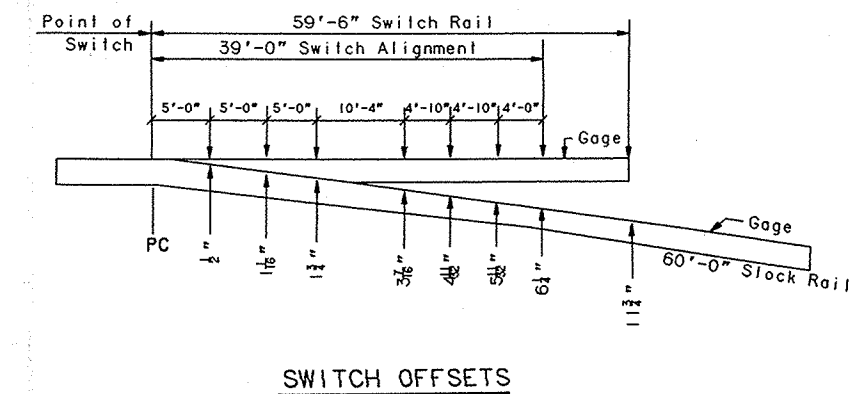

SWITCH OFFSETS

Switch Rod Lengths

No. 1	5'-10"
No. 2	5'-10"
No. 3	4'-4"
No. 4	4'-4"
No. 5	5'-10"
No. 6	5'-10"

	RAILROAD OPERATIONS	DWG. NO. 2215
	APR. 29, 1996	ISSUE NO. 3
39' CURVED SPLIT SWITCH WITH FLOATING HEEL BLOCKS		
 SECTION CHIEF		

NO. 20 TURNOUT WITH FLOATING HEEL BLOCKS -
BILL OF MATERIAL

QUANTITY	DESCRIPTION	REFERENCE PLAN NO.
1*	PAIR 59'-6" CURVED SWITCH POINTS COMPLETE WITH REINFORCING BARS, CLIPS AND STOPS ATTACHED.	2215
2	FLOATING HEEL BLOCKS	2350
2	60'-0" UNDERCUT STOCK RAILS	2360
3	INSULATED GAGE PLATES (NO. 0G, 1G, & 2G)	2207
16	NO. 1 ADJUSTABLE BRACE SLIDE PLATES	2207
26	NO. 1P SHOULDER SLIDES PLATES	2207
4	NO. HP HEEL PLATES	2207
6	SWITCH RAIL STOPS	2350
12	ADJUSTABLE ROCKER CLIPS FOR VERTICAL SWITCH RODS	2208
6	INSULATED VERTICAL SWITCH RODS (NO. 1, 2, 3, 4, 5, & 6)	2208
40*	TURNOUT PLATES FOR USE BEHIND HEEL OF SWITCH (NO. 20-2 R/L TO 20-8 R/L & 20-9 TO 20-21)x2	2343
22	RESILIENTLY FASTENED ADJUSTABLE RAIL BRACE	2352
1	NO. 20 RAILBOUND MANGANESE STEEL FROG, COMPLETE	2206
20	NO. P27 SELF ALIGNING SHOULDER TIE PLATE	2328
28	NO. P31 SELF ALIGNING SHOULDER TIE PLATE	2328
10	NO. PR27 SELF ALIGNING SHOULDER TIE PLATE	2328
2	NO. PR31 SELF ALIGNING SHOULDER TIE PLATE	2328
2	13'-3" MANGANESE STEEL ONE PIECE GUARD RAILS	2302
2	19'-6" BONDED INSULATED JOINT PLUG RAIL	1340
3	78'-0" LENGTHS OF FULLY HEAT TREATED RAIL	-
4	39'-0" LENGTHS OF FULLY HEAT TREATED RAIL	-
1 EA. +	VARIOUS LENGTHS OF FULLY HEAT TREATED RAIL AS FOLLOWS: 42'-11 1/2", 37'-4", 25'-1 1/2"	-
1744	3/4" SCREW SPIKES	1218
78**	1/2" x 6" TRACK DRIVE SPIKES	1217
838	RESILIENT FASTENER SPRING CLIPS - TYPE "E"	-
8	RESILIENT FASTENER SPRING CLIPS - TYPE MODIFIED "E"	-
286	RESILIENT FASTENER TIE PLATES FOR SCREW SPIKES	1225
14	1:80 CANT TRANSITION TIE PLATES	2348
20	STANDARD JOINT BAR ASSEMBLIES	1322
80	STANDARD TRACK BOLTS WITH NUTS & WASHERS	1332
1	HELPER LAYOUT	2209

* THESE ITEMS SHALL BE SUPPLIED FOR R.H., L.H. OR EQUILATERAL TURNOUT, AS REQUIRED
+ FOR EQUILATERAL TURNOUTS. CLOSURE RAILS HAVE SLIGHTLY DIFFERENT LENGTHS
** SUPPLIED BY THE INSTALLER

T MASSACHUSETTS BAY TRANSPORTATION AUTHORITY	RAILROAD OPERATIONS	DWG. NO. 2210
		APR. 29, 1996 ISSUE DATE

NO. 20 FLOATING HEEL BLOCK TURNOUT
BILL OF MATERIAL

John D. Rany
SECTION CHIEF

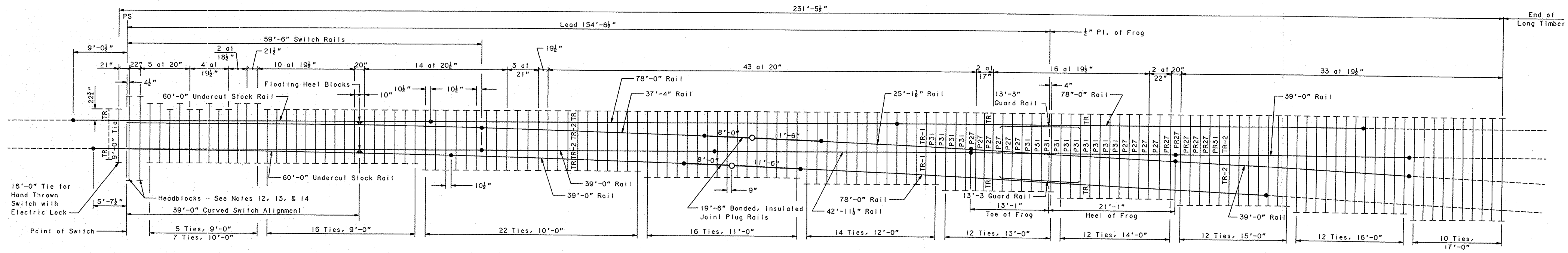

NOTES

- 1-Stock rails, switch points and all rails furnished to be fully heat treated.
- 2-Switch Points per AREA Detail 5100 as shown on Plan 2205.
- 3-60' stock rails to be undercul as per Plan 2360.
- 4-For switch details see Plan 2215.
- 5-Gage plates No. 0G, 1G & 2G as per Plan 2207.
- 6-Switch plates Nos. 1, 1P and HP as per Plan 2207.
- 7-Turnout plates, No. 2 thru No. 21, as per Plan 2343.
- 8-Vertical insulated switch rods and adjustable rocker clips, as per Plan 2208.
- 9-Floating Heel block as per Plan 2350.
- 10-All rails to be drilled as shown on this plan, except that first hole is not to be drilled by the manufacturer. Installer to field drill first hole when necessary.
- 11-All tie plates to be resiliently fastened except guard rails.
- 12-Two 9"x10"x13' Headblocks needed with switch stand 3' high or less, 16' long with stands over 3'.
- 13-Three 9"x10"x16' Headblocks needed for hand thrown switch with electric lock.
- 14-Two 9"x10"x14' Headblocks needed for power operated switch.
- 15-See Plan 2210 for Bill of Material.
- 16-Rail lengths are computed to allow a 1/4" gap for temporarily bolting the field welded joints and 1/8" gap for insulated joints. When rails are welded in the field, they must be cut to provide gaps recommended by the weld kil manufacturer.
- 17-Transition Plates (TR) 1:80 Cant, as per Plan 2348.

LEGEND

- Indicates rails furnished by the manufacturer.
- - - - - Indicates rails furnished by the installer.
- ▲ Indicates "floating" heel blocks..
- Indicates insulated joints with 3/16" opening.
- Indicates joints to be field welded.
- Indicates Bonded Insulated Joint Plug Rail

FROG TIE PLATES

- 20 - P27 SAS (self-aligning shoulder)
- 28 - P31 SAS
- 10 - PR27 SAS
- 2 - PR31 SAS

LONG TIMBERS REQUIRED

Quantity	Length
22	9'-0"
29	10'-0"
16	11'-0"
12	12'-0"
12	13'-0"
14	14'-0"
12	15'-0"
12	16'-0"
10	17'-0"
139	Total

Headblocks are not shown in table see notes 12, 13 & 14

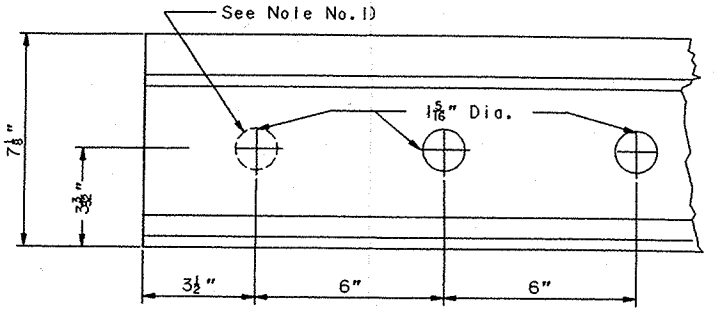

RAIL END DRILLING

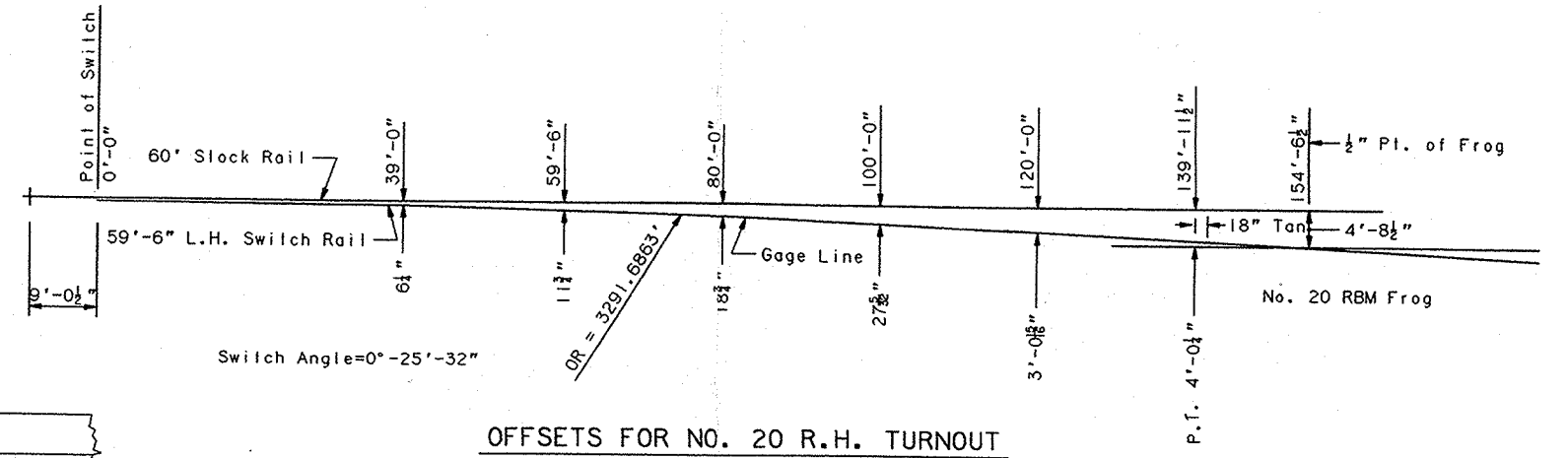

OFFSETS FOR NO. 20 R.H. TURNOUT

	RAILROAD OPERATIONS	DWG. NO. 2212
	ISSUE DATE	Apr. 29, 1996
NO. 20 TURNOUT WITH FLOATING HEEL BLOCKS - TIE & RAIL LAYOUT		SECTION CHIEF

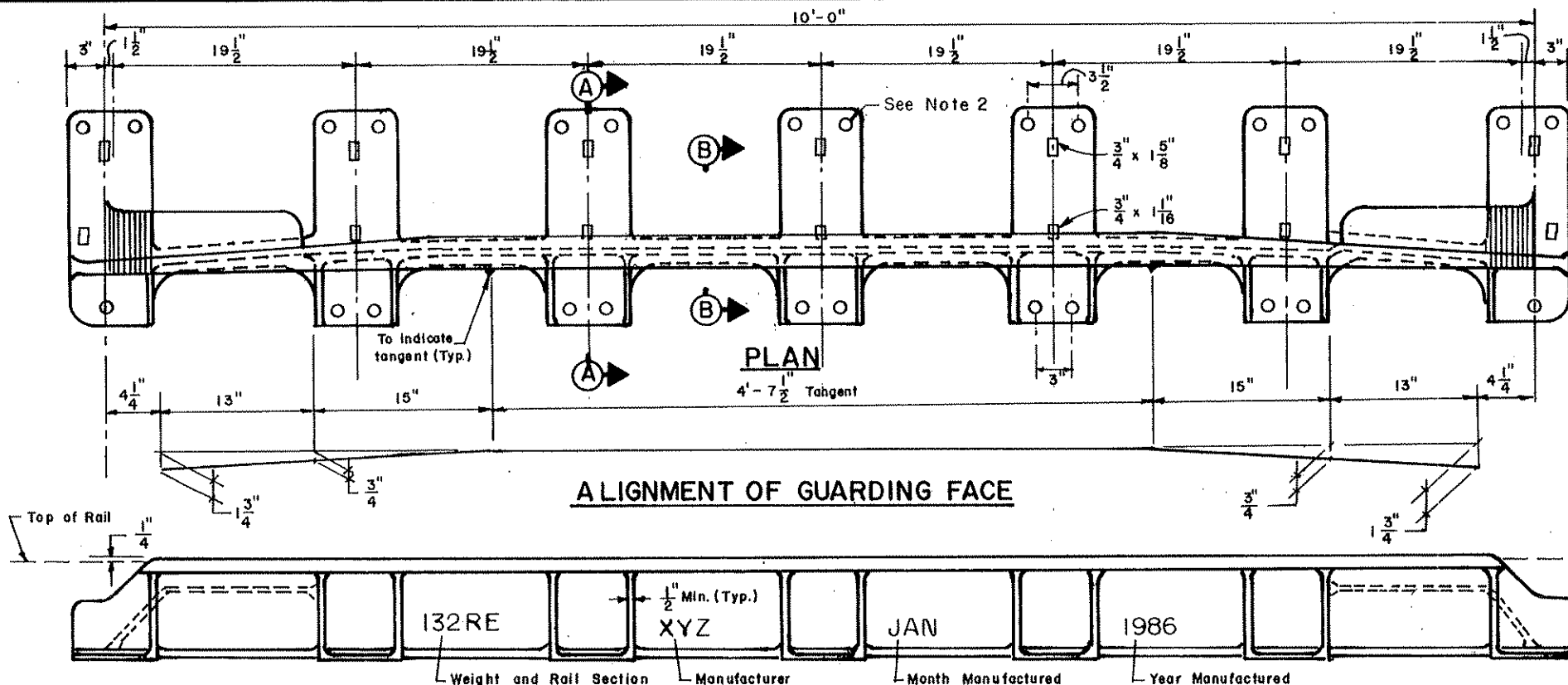

ALIGNMENT OF GUARDING FACE

ELEVATION

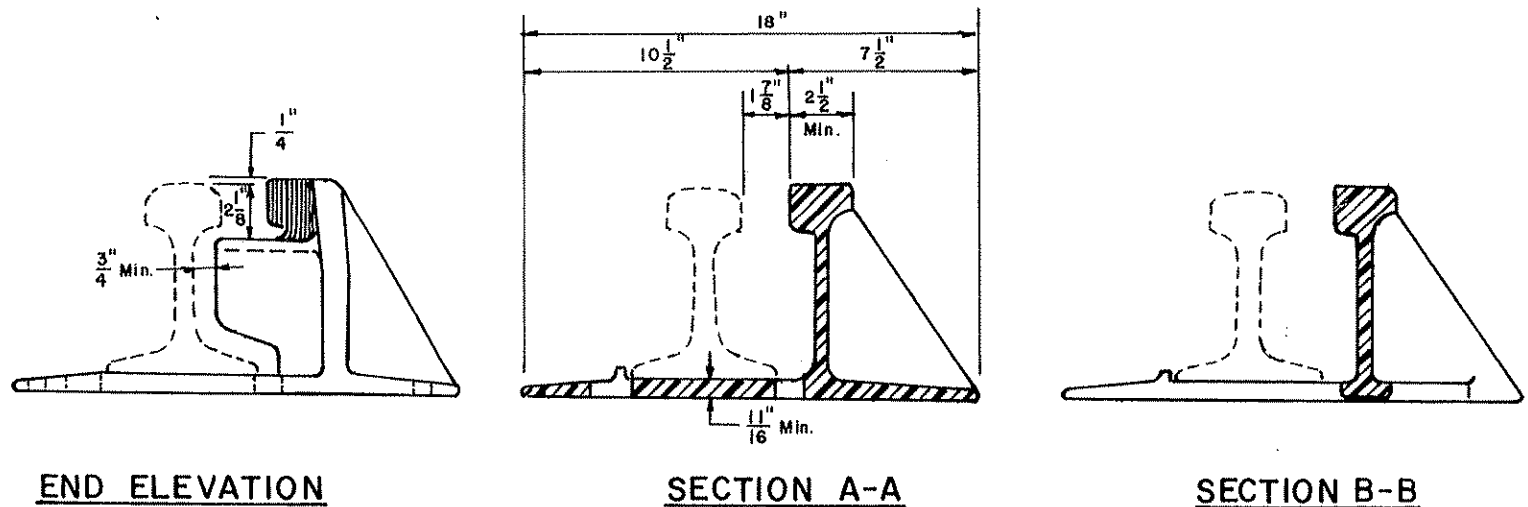

- NOTES:**
1. For details of setting guard rail, see Plan 2310.
 2. Furnish with 15/16" diameter holes.

	MASSACHUSETTS BAY TRANSPORTATION AUTHORITY	RAILROAD OPERATIONS	DWG. NO. 2300 Oct. 28, 1992 <small>ISSUE DATE</small>	(2) <small>ISSUE NO.</small>
	10'-0" MANGANESE STEEL ONE PIECE GUARD RAIL			
<i>John D. Ray</i> <small>ENGINEERING OFFICER</small>		<i>W. H. Conolly</i> <small>CHIEF ENGINEERING OFFICER</small>		

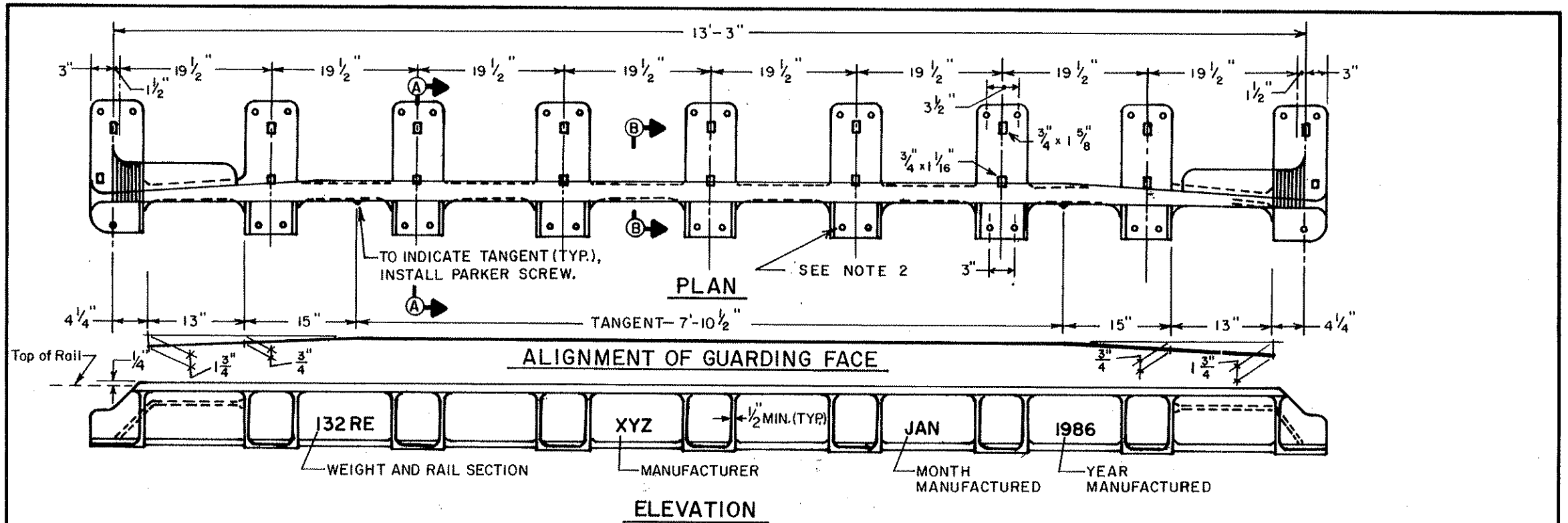

13'-3" ONE PIECE MANGANESE STEEL GUARD RAIL

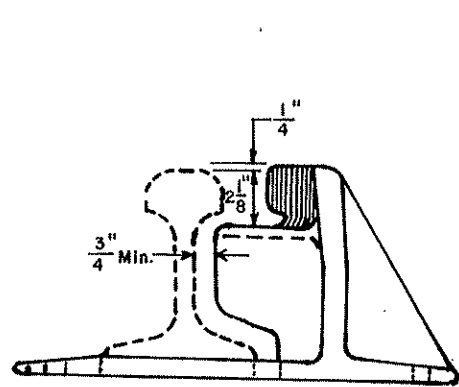

END ELEVATION

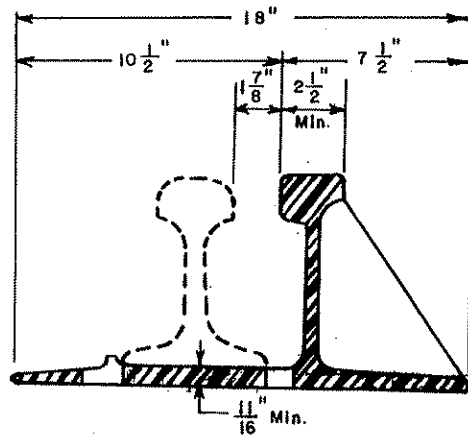

SECTION A-A

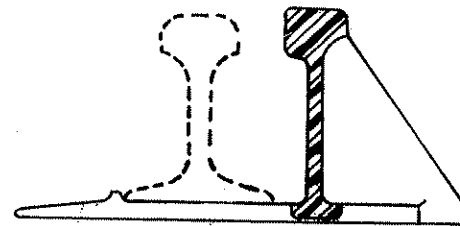

SECTION B-B

NOTES:

1. For details of setting guard rail, see Plan 2310.
2. Furnish with 15/16" diameter holes.

T	MASSACHUSETTS BAY TRANSPORTATION AUTHORITY	RAILROAD OPERATIONS	DWG. NO. 2302
			Oct. 28, 1992 ISSUE DATE
13'-3" MANGANESE STEEL ONE PIECE GUARD RAIL		 ENGINEERING OFFICER	
		 CHIEF ENGINEERING OFFICER	

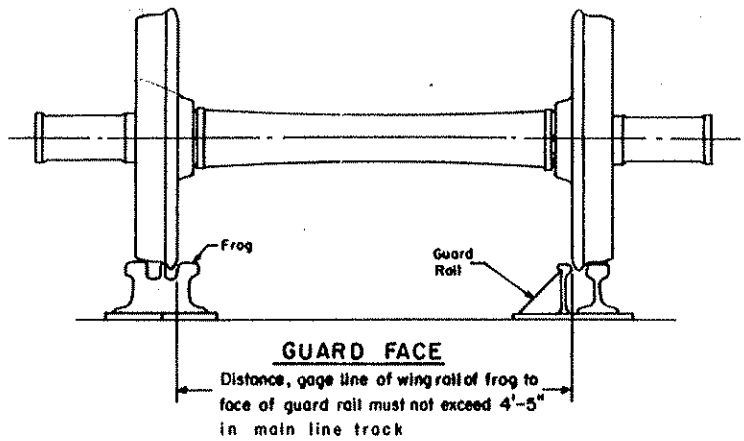
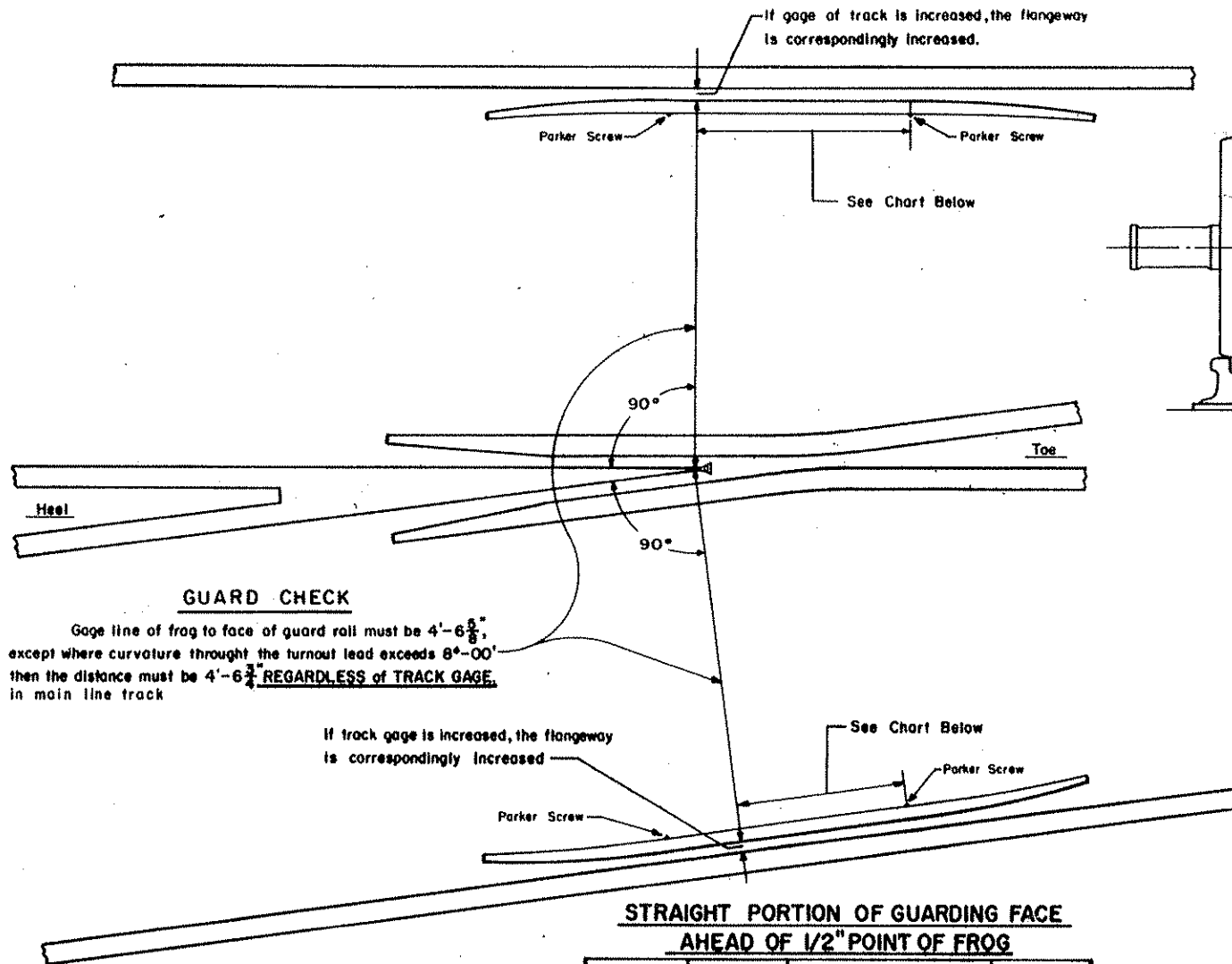

GUARD CHECK
 Gage line of frog to face of guard rail must be 4'-6 $\frac{3}{8}$ "
 except where curvature through the turnout lead exceeds 8°-00'
 then the distance must be 4'-6 $\frac{3}{4}$ " **REGARDLESS of TRACK GAGE,**
 in main line track

If track gage is increased, the flangeway
 is correspondingly increased

**STRAIGHT PORTION OF GUARDING FACE
 AHEAD OF 1/2" POINT OF FROG**

FROG NO.	GUARD RAIL LENGTH	DESIRED SETTING (BASED ON TIE & RAIL LAYOUT PLANS IN BOOK)	SAFETY MINIMUM
6	10'-0"		22"
8	10'-0"	3'-7 $\frac{1}{4}$ "	22"
10	13'-3"	4'-3 $\frac{1}{4}$ "	22"
15	13'-3"	5'-2 $\frac{3}{4}$ "	22"
20	13'-3"	5'-2 $\frac{3}{4}$ "	36"

NOTES

- 1 - Guard rails must conform to MBTA Specifications for one piece manganese steel guard rails.
- 2 - Each tie bearing portion of the guard rails must be fully supported by a tie, which shall be kept well tamped at all times.
- 3 - For details of guard rails see Plan No. 2300 & 2302.
- 4 - Parker Screws on the back of the guard rail indicates the extent of the straight portion of the guarding face.
- 5 - For Additional data, See MW-1 Manual - Section 213.143

T MASSACHUSETTS BAY TRANSPORTATION AUTHORITY	RAILROAD OPERATIONS	DWG. NO. 2310
		Oct. 28, 1992 2 ISSUE DATE ISSUE NO.
GUARD RAIL INSTALLATION AND MAINTENANCE		
<i>John D. Ray</i> ENGINEERING OFFICER	<i>W. A. ...</i> CHIEF ENGINEERING OFFICER	

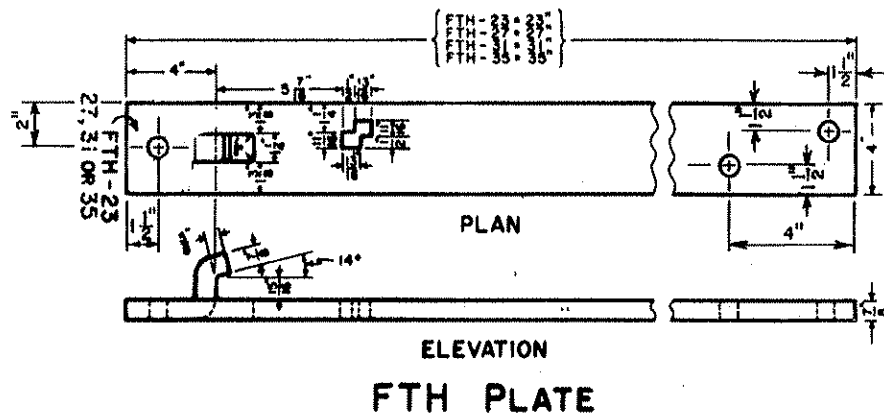
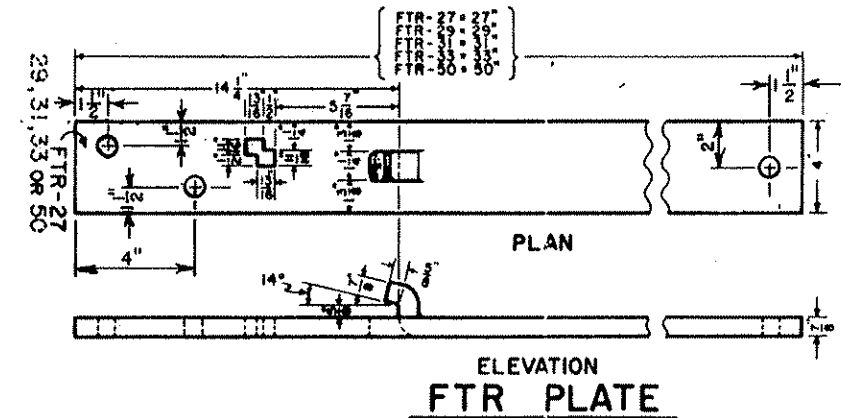
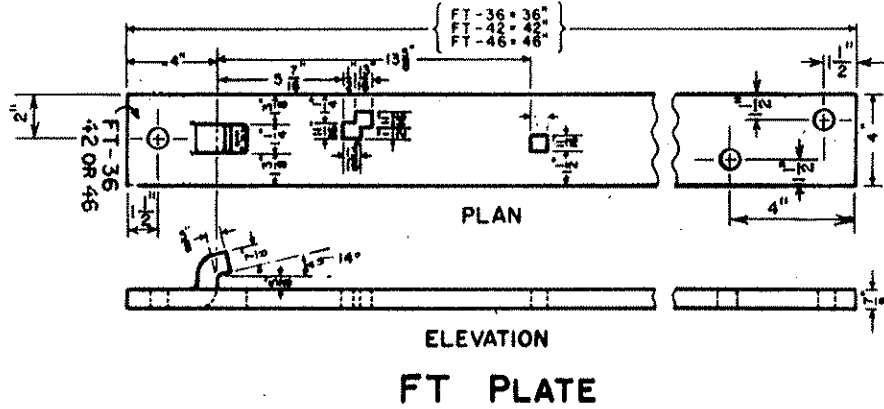
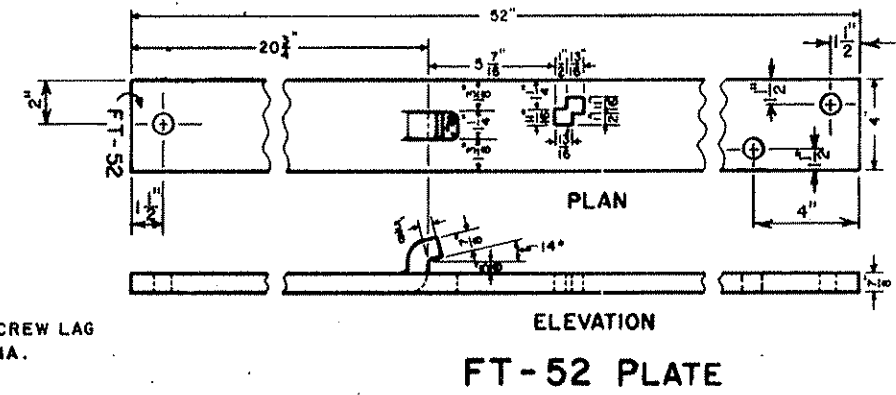
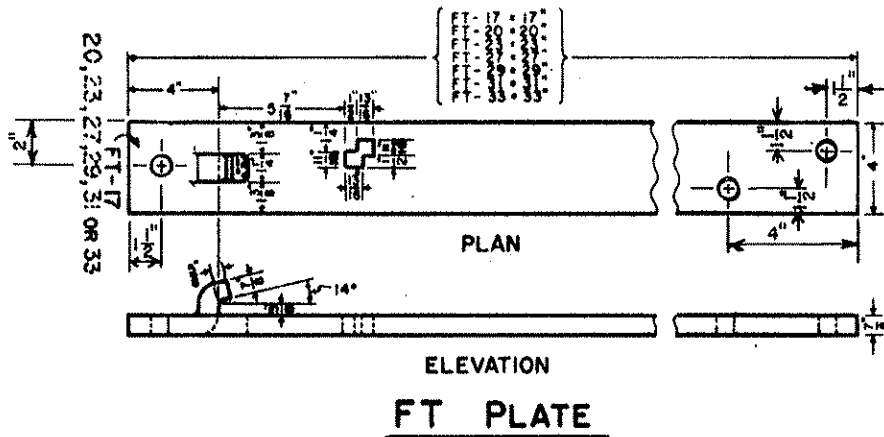
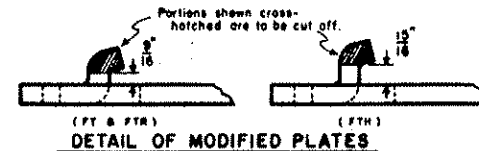

PLATE DESIGNATION

- FT = Frog Tie Plate
- FTH = Frog Tie Plate (High Hook)
- FTR = Frog Tie Plate (Reverse Hook)
- FT-MOD. } Modified plates will
- FTH-MOD. } have the hook cut back
- FTR-MOD. } as detailed below.



Note
Where hook on Frog Tie Plate will impinge upon base of frog or base of joint bar, the Frog Tie Plate must be modified as detailed.

NOTES

- Plates shall conform to the current A.R.E.A. Specifications for Low-Carbon Steel Tie Plates, with copper.
- Each plate shall be marked by deeply cut characters, not less than one half inch high, in the position as indicated on this plan, with the plate designation as shown.

T	MASSACHUSETTS BAY TRANSPORTATION AUTHORITY	RAILROAD OPERATIONS	DWG. NO. 2326
			Oct. 28, 1992
		(2) ISSUE NO.	
FROG TIE PLATES RAILBOUND MANGANESE FROG			
<i>John D. Ray</i>		<i>W. A. ...</i>	
ENGINEERING OFFICER		CHIEF ENGINEERING OFFICER	

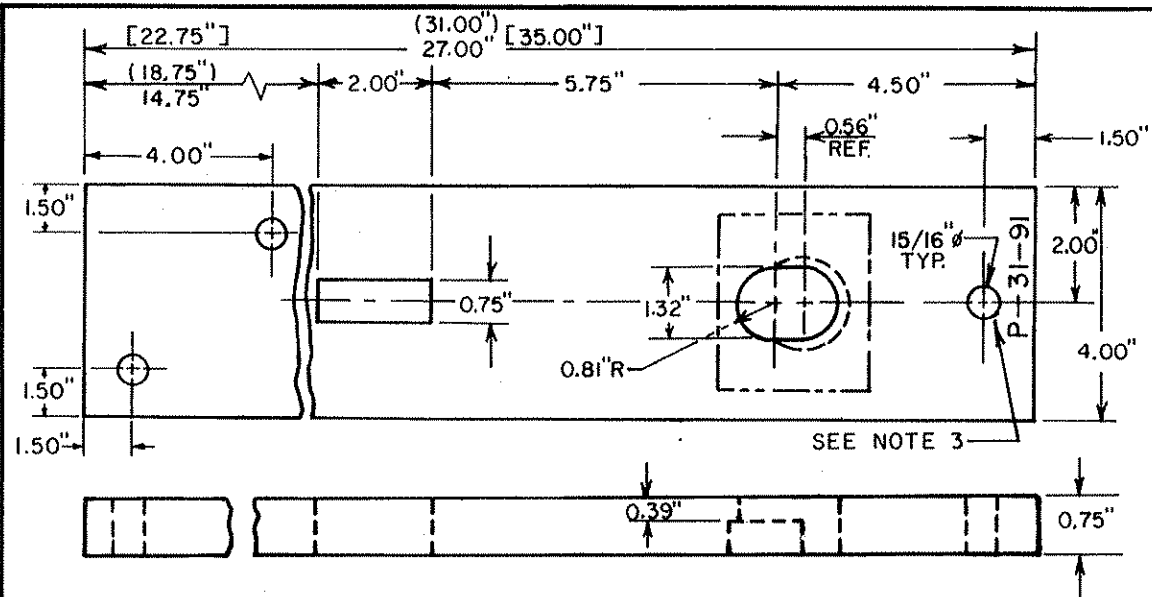

NORMAL FROG PLATE

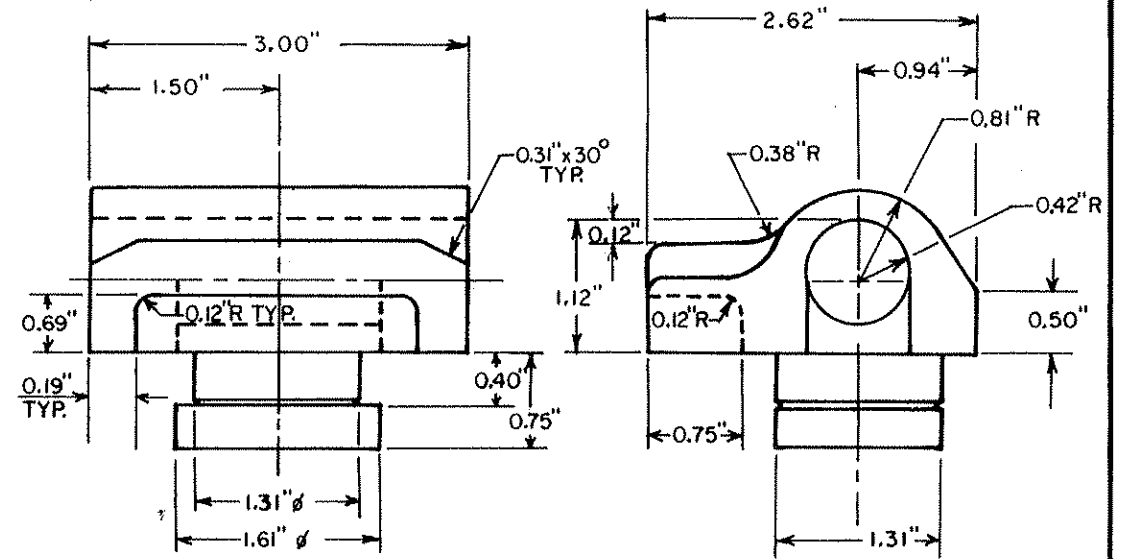

Note: Unspecified radii to be 0.06" max.
SWIVEL SHOULDER INSERT

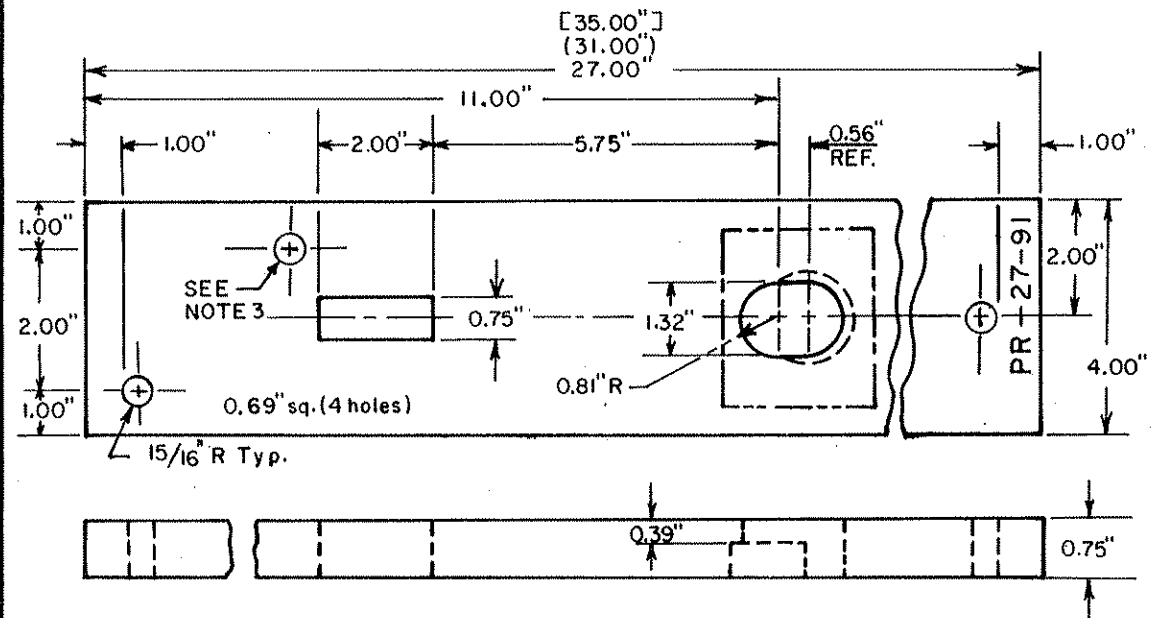

REVERSE FROG PLATE

NOTES:

1. Plates shown are manufactured by PANDROL, INC.
2. Material shall be Low-Carbon Steel and the plates shall conform to current A.R.E.A. specifications.
3. Furnish plates with 15/16" diameter holes for screw lags.
4. Tie plates shall be branded with a letter to designate the manufacturer, the letter 'R' when the plate is reverse shoulder, two numbers indicating the length (27", 31" or 35"), and the last two digits of the year manufactured.

T	MASSACHUSETTS BAY TRANSPORTATION AUTHORITY	RAILROAD OPERATIONS	DWG. NO. 2328
			Jan. 5, 1996 2 ISSUE DATE ISSUE NO.
SELF-ALIGNING SHOULDER TIE PLATES			
<i>John D. Ray</i> SECTION CHIEF			

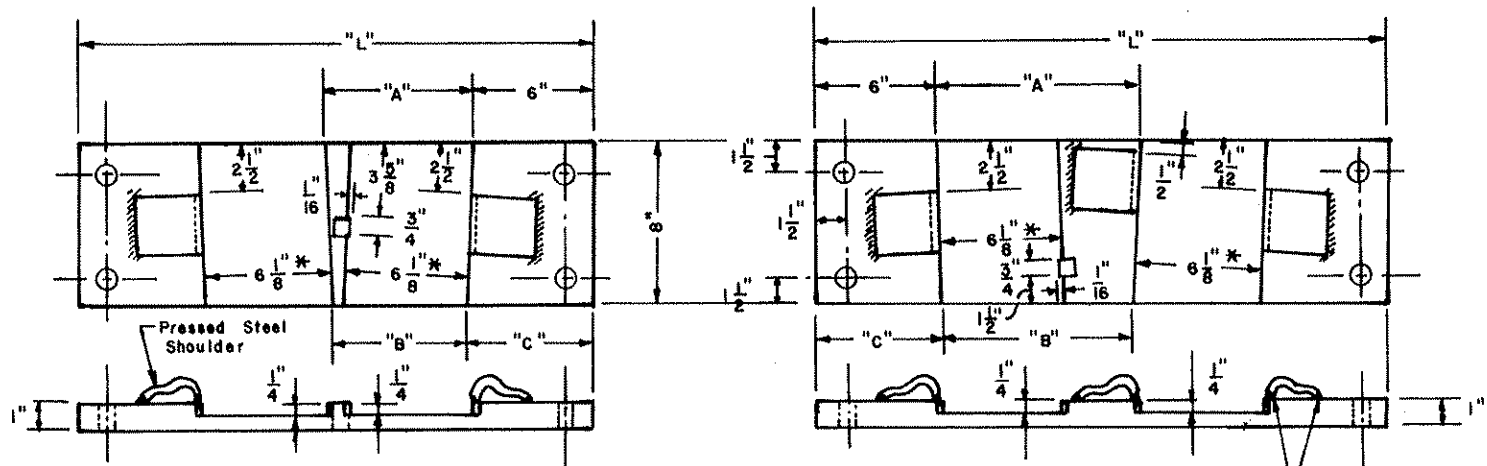

PLATES 8-2, 10-2, 15-2 & 20-2
(2 PER TURNOUT)

PLATE 8-6
PLATE 10-6
PLATES 15-6 & 15-7
PLATES 20-9 & 20-10
(2 PER TURNOUT)

Mark Plate Designation on Alternate Ends of Plates so that it will always be on the Field Side

* $6\frac{1}{8}$ " for 132 RE rail, $5\frac{5}{8}$ " for 115 RE rail.

NOTES:

1. First number in plate designation is turnout frog number, second is number of ties from heel block which counts as one.
2. Switch plates shall conform to current AREA specifications, Low-Carbon Steel Tie Plates with Copper.
3. Round holes for plate holding screw lugs are $15/16$ " dia.
4. Rectangular holes for track spikes are $3/4$ " x $13/16$ " with $1/16$ " under the rail base.
5. Welds shall not interfere with the application of the resilient fasteners. Welds shall be full penetration groove welds.
6. Plates shown are for a graduated riser turnout only.
7. Variable dimensions A, B, C & L are shown on the following plan (No. 2341).
8. Each plate shall be marked with deeply cut characters not less than $1/2$ " high, in the positions indicated on this plan.

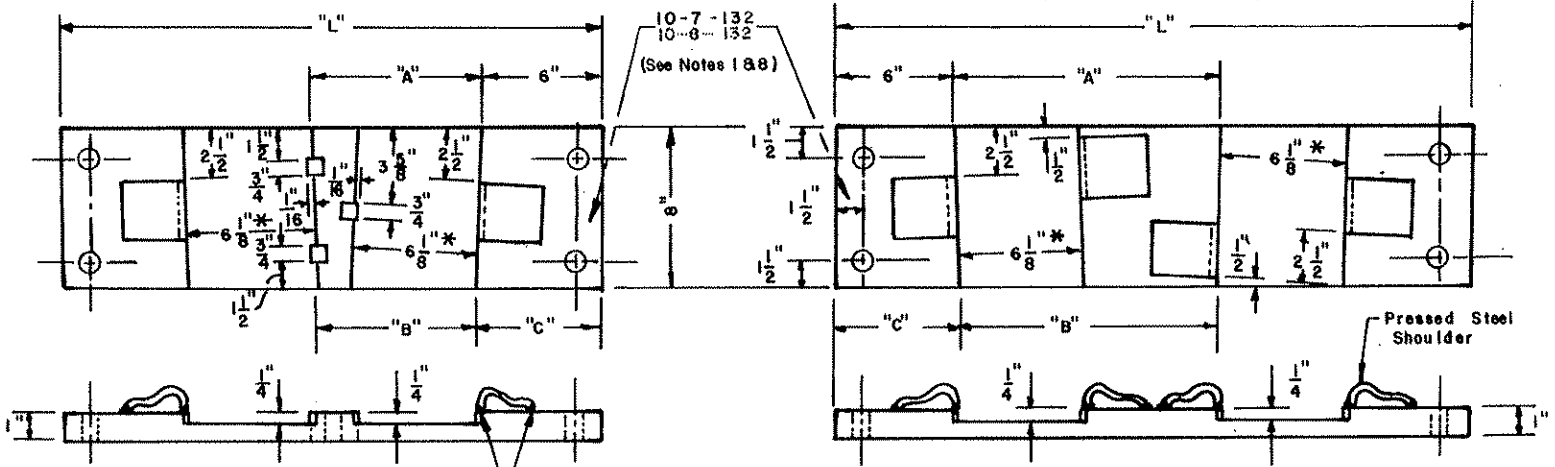

PLATES 8-3 TO 8-5
PLATES 10-3 TO 10-5
PLATES 15-3 TO 15-5
PLATES 20-3 TO 20-5
(2 PER TURNOUT)

PLATES 8-7 TO 8-11
PLATES 10-7 TO 10-12
PLATES 15-8 TO 15-14
PLATES 20-11 TO 20-21
(2 PER TURNOUT)

T	MASSACHUSETTS BAY TRANSPORTATION AUTHORITY	RAILROAD OPERATIONS	DWG. NO. 2340.
			Oct. 28, 1992 2 ISSUE DATE ISSUE NO.
RESILIENTLY FASTENED TURNOUT PLATES NUMBER 8, 10, 15, 20 TURNOUTS FOR USE BEHIND HEEL OF SWITCH WITH GRADUATED RISERS			
<i>John D. Ray</i> ENGINEERING OFFICER		<i>W. A. ...</i> CHIEF ENGINEERING OFFICER	

NO. 8 TURNOUT				
Plate No.	A	B	C	L
8-2	7 ⁵ / ₁₆ "	7 ¹ / ₃₂ "	6 ¹ / ₈ "	25 ¹ / ₂ "
8-3	7 ³¹ / ₃₂ "	7 ¹¹ / ₁₆ "	6 ¹ / ₈ "	26 "
8-4	8 ²¹ / ₃₂ "	8 ³ / ₈ "	6 ⁵ / ₃₂ "	27 "
8-5	9 ¹⁵ / ₃₂ "	9 ¹ / ₈ "	6 ⁵ / ₃₂ "	27 ¹ / ₂ "
8-6	10 ⁵ / ₁₆ "	9 ³¹ / ₃₂ "	6 ³ / ₁₆ "	29 "
8-7	11 ¹ / ₄ "	10 ⁷ / ₈ "	6 ³ / ₁₆ "	29 ¹ / ₂ "
8-8	12 ¹ / ₄ "	11 ²⁷ / ₃₂ "	6 ³ / ₁₆ "	30 ¹ / ₂ "
8-9	13 ⁵ / ₁₆ "	12 ⁷ / ₈ "	6 ⁷ / ₃₂ "	31 ¹ / ₂ "
8-10	14 ¹⁵ / ₃₂ "	14 "	6 ⁷ / ₃₂ "	32 ¹ / ₂ "
8-11	15 ¹¹ / ₁₆ "	15 ³ / ₁₆ "	6 ¹ / ₄ "	34 "

NO. 10 TURNOUT				
Plate No.	A	B	C	L
10-2	7 ⁵ / ₁₆ "	7 ¹ / ₁₆ "	6 ¹ / ₈ "	25 ¹ / ₂ "
10-3	7 ¹⁵ / ₁₆ "	7 ¹¹ / ₁₆ "	6 ¹ / ₈ "	26 "
10-4	8 ⁵ / ₈ "	8 ¹¹ / ₃₂ "	6 ¹ / ₈ "	27 "
10-5	9 ¹¹ / ₃₂ "	9 ¹ / ₃₂ "	6 ⁵ / ₃₂ "	27 ¹ / ₂ "
10-6	10 ³ / ₃₂ "	9 ²⁵ / ₃₂ "	6 ⁵ / ₃₂ "	28 ¹ / ₂ "
10-7	10 ²⁹ / ₃₂ "	10 ⁹ / ₁₆ "	6 ⁵ / ₃₂ "	29 "
10-8	11 ²⁵ / ₃₂ "	11 ¹³ / ₃₂ "	6 ³ / ₁₆ "	30 "
10-9	12 ²¹ / ₃₂ "	12 ⁹ / ₃₂ "	6 ³ / ₁₆ "	31 "
10-10	13 ⁵ / ₈ "	13 ⁷ / ₃₂ "	6 ³ / ₁₆ "	32 "
10-11	14 ¹⁹ / ₃₂ "	14 ⁷ / ₁₆ "	6 ³ / ₁₆ "	33 "
10-12	15 ⁵ / ₈ "	15 ⁷ / ₃₂ "	6 ⁷ / ₃₂ "	33 ¹ / ₂ "

NO. 15 TURNOUT				
Plate No.	A	B	C	L
15-2	7 ⁷ / ₃₂ "	6 ³¹ / ₃₂ "	6 ¹ / ₈ "	25 ¹ / ₂ "
15-3	7 ²⁵ / ₃₂ "	7 ⁹ / ₁₆ "	6 ¹ / ₈ "	26 "
15-4	8 ³ / ₈ "	8 ⁵ / ₃₂ "	6 ¹ / ₈ "	26 ¹ / ₂ "
15-5	9 "	8 ³ / ₄ "	6 ¹ / ₈ "	27 "
15-6	9 ⁵ / ₈ "	9 ³ / ₈ "	6 ¹ / ₈ "	28 "
15-7	10 ⁵ / ₁₆ "	10 ¹ / ₃₂ "	6 ¹ / ₈ "	28 ¹ / ₂ "
15-8	10 ³¹ / ₃₂ "	10 ¹¹ / ₁₆ "	6 ¹ / ₈ "	29 "
15-9	11 ²¹ / ₃₂ "	11 ³ / ₈ "	6 ¹ / ₈ "	30 "
15-10	12 ³ / ₈ "	12 ¹ / ₁₆ "	6 ⁵ / ₃₂ "	30 ¹ / ₂ "
15-11	13 ³ / ₃₂ "	12 ²⁵ / ₃₂ "	6 ⁵ / ₃₂ "	31 ¹ / ₂ "
15-12	13 ²⁷ / ₃₂ "	13 ¹⁷ / ₃₂ "	6 ⁵ / ₃₂ "	32 "
15-13	14 ¹⁹ / ₃₂ "	14 ⁹ / ₃₂ "	6 ⁵ / ₃₂ "	33 "
15-14	15 ³ / ₈ "	15 ¹ / ₁₆ "	6 ⁵ / ₃₂ "	33 ¹ / ₂ "

NO. 20 TURNOUT				
Plate No.	A	B	C	L
20-2	6 ²⁹ / ₃₂ "	6 ³ / ₄ "	6 ³ / ₃₂ "	25 "
20-3	7 ⁵ / ₁₆ "	7 ⁵ / ₃₂ "	6 ³ / ₃₂ "	25 ¹ / ₂ "
20-4	7 ²³ / ₃₂ "	7 ⁹ / ₁₆ "	6 ³ / ₃₂ "	26 "
20-5	8 ¹ / ₈ "	7 ³¹ / ₃₂ "	6 ³ / ₃₂ "	26 ¹ / ₂ "
20-6	8 ⁹ / ₁₆ "	8 ³ / ₈ "	6 ³ / ₃₂ "	27 "
20-7	9 "	8 ¹³ / ₁₆ "	6 ³ / ₃₂ "	27 ¹ / ₂ "
20-8	9 ⁷ / ₁₆ "	9 ¹ / ₄ "	6 ³ / ₃₂ "	27 ¹ / ₂ "
20-9	9 ²⁹ / ₃₂ "	9 ²³ / ₃₂ "	6 ³ / ₃₂ "	28 "
20-10	10 ³ / ₈ "	10 ⁵ / ₃₂ "	6 ³ / ₃₂ "	28 ¹ / ₂ "
20-11	10 ²⁷ / ₃₂ "	10 ⁵ / ₈ "	6 ³ / ₃₂ "	29 "
20-12	11 ⁵ / ₁₆ "	11 ¹ / ₈ "	6 ³ / ₃₂ "	29 ¹ / ₂ "
20-13	11 ¹³ / ₁₆ "	11 ¹⁹ / ₃₂ "	6 ³ / ₃₂ "	30 "
20-14	12 ⁵ / ₁₆ "	12 ³ / ₃₂ "	6 ³ / ₃₂ "	30 ¹ / ₂ "
20-15	12 ¹³ / ₁₆ "	12 ⁵ / ₈ "	6 ³ / ₃₂ "	31 "
20-16	13 ¹¹ / ₃₂ "	13 ¹ / ₈ "	6 ¹ / ₈ "	31 ¹ / ₂ "
20-17	13 ⁷ / ₈ "	13 ²¹ / ₃₂ "	6 ¹ / ₈ "	32 "
20-18	14 ⁷ / ₁₆ "	14 ³ / ₁₆ "	6 ¹ / ₈ "	32 ¹ / ₂ "
20-19	14 ³¹ / ₃₂ "	14 ³ / ₄ "	6 ¹ / ₈ "	33 ¹ / ₂ "
20-20	15 ⁹ / ₁₆ "	15 ⁵ / ₁₆ "	6 ¹ / ₈ "	34 "
20-21	16 ¹ / ₃₂ "	15 ³ / ₄ "	6 ¹ / ₈ "	34 ¹ / ₂ "

NOTES

- 1— See previous plan (No. 2340-1) for diagram showing the location of dimensions A, B, C, & L.
- 2— Dimensions shown are only for tie spacings shown on corresponding Tie and Rail Layout Plans.

T	MASSACHUSETTS BAY TRANSPORTATION AUTHORITY	RAILROAD OPERATIONS	DWG. NO. 2341
			Oct. 28, 1992 ISSUE DATE
TABLE OF DIMENSIONS FOR RESILIENTLY FASTENED TURNOUT PLATES			
<i>Julie D. Ray</i>		<i>W. H. Cole</i>	
ENGINEERING OFFICER		CHIEF ENGINEERING OFFICER	

PLATE No.	A	B	X	Y	L
8-2 R/L	7 $\frac{15}{32}$ "	7 $\frac{7}{32}$ "	$\frac{1}{16}$ "	$\frac{15}{16}$ "	25 $\frac{1}{2}$ "
8-3 R/L	8 $\frac{5}{32}$ "	7 $\frac{7}{8}$ "	$\frac{1}{8}$ "	$\frac{7}{8}$ "	26 $\frac{1}{2}$ "
8-4 R/L	8 $\frac{15}{16}$ "	8 $\frac{5}{8}$ "	$\frac{3}{16}$ "	$\frac{13}{16}$ "	27"
8-5 R/L	9 $\frac{13}{16}$ "	9 $\frac{15}{32}$ "	$\frac{1}{4}$ "	$\frac{3}{4}$ "	28"
10-2 R/L	7 $\frac{11}{32}$ "	7 $\frac{3}{32}$ "	$\frac{1}{16}$ "	$\frac{15}{16}$ "	25 $\frac{1}{2}$ "
10-3 R/L	7 $\frac{31}{32}$ "	7 $\frac{3}{4}$ "	$\frac{1}{8}$ "	$\frac{7}{8}$ "	26"
10-4 R/L	8 $\frac{3}{4}$ "	8 $\frac{15}{32}$ "	$\frac{3}{16}$ "	$\frac{13}{16}$ "	27"
10-5 R/L	9 $\frac{17}{32}$ "	9 $\frac{1}{4}$ "	$\frac{1}{4}$ "	$\frac{3}{4}$ "	28"

PLATE No.	A	B	C	L
8-6	10 $\frac{3}{4}$ "	9 $\frac{31}{32}$ "	6 $\frac{3}{16}$ "	29"
8-7	11 $\frac{3}{4}$ "	11 $\frac{11}{32}$ "	6 $\frac{3}{16}$ "	30"
8-8	12 $\frac{27}{32}$ "	12 $\frac{7}{16}$ "	6 $\frac{3}{16}$ "	31"
8-9	14 $\frac{1}{2}$ "	13 $\frac{9}{16}$ "	6 $\frac{3}{16}$ "	32 $\frac{1}{2}$ "
8-10	15 $\frac{9}{32}$ "	14 $\frac{25}{32}$ "	6 $\frac{1}{4}$ "	33 $\frac{1}{2}$ "
8-11	16 $\frac{7}{16}$ "	16 $\frac{3}{32}$ "	6 $\frac{1}{4}$ "	35"
10-6	10 $\frac{3}{8}$ "	10 $\frac{1}{16}$ "	6 $\frac{3}{16}$ "	29"
10-7	11 $\frac{9}{32}$ "	10 $\frac{15}{16}$ "	6 $\frac{3}{16}$ "	29 $\frac{1}{2}$ "
10-8	12 $\frac{7}{8}$ "	11 $\frac{27}{32}$ "	6 $\frac{3}{16}$ "	30 $\frac{1}{2}$ "
10-9	13 $\frac{9}{32}$ "	12 $\frac{13}{16}$ "	6 $\frac{3}{16}$ "	31 $\frac{1}{2}$ "
10-10	14 $\frac{1}{4}$ "	13 $\frac{27}{32}$ "	6 $\frac{3}{16}$ "	32 $\frac{1}{2}$ "
10-11	15 $\frac{11}{32}$ "	14 $\frac{15}{16}$ "	6 $\frac{3}{16}$ "	33 $\frac{1}{2}$ "
10-12	16 $\frac{1}{2}$ "	16 $\frac{1}{16}$ "	6 $\frac{3}{16}$ "	35"

* 6 $\frac{1}{8}$ " for 132 & 136 RE Rail, 5 $\frac{5}{8}$ " for 115 RE Rail.

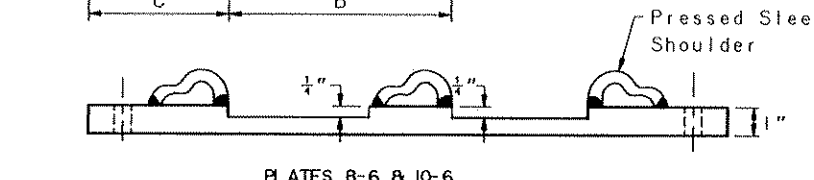
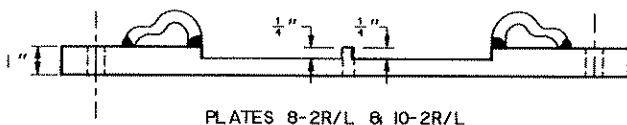
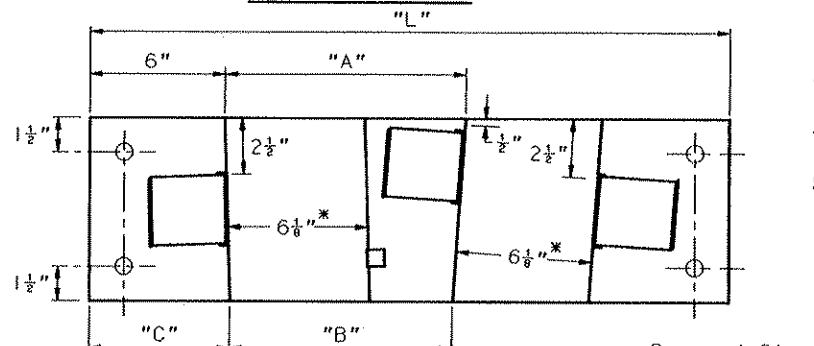
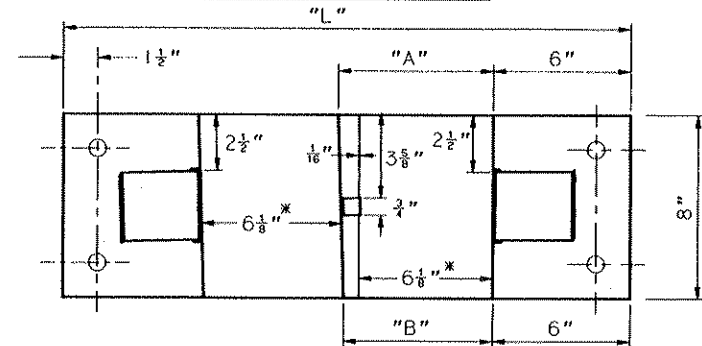
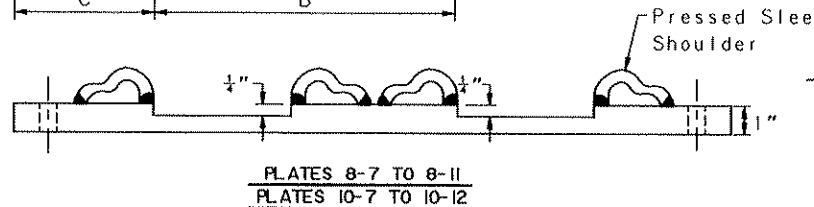
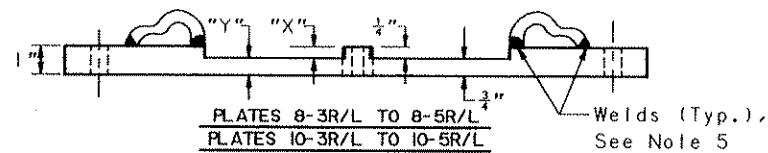
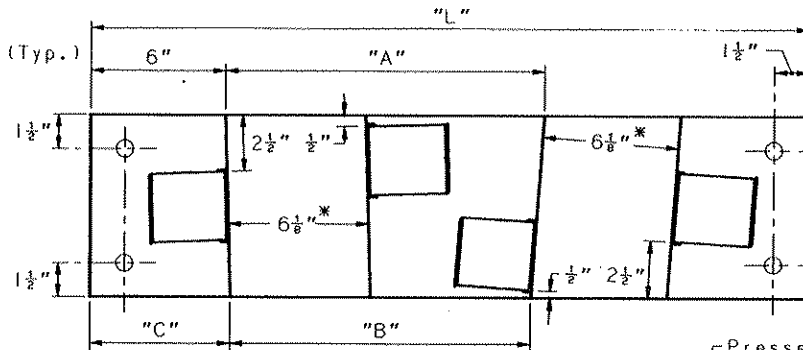
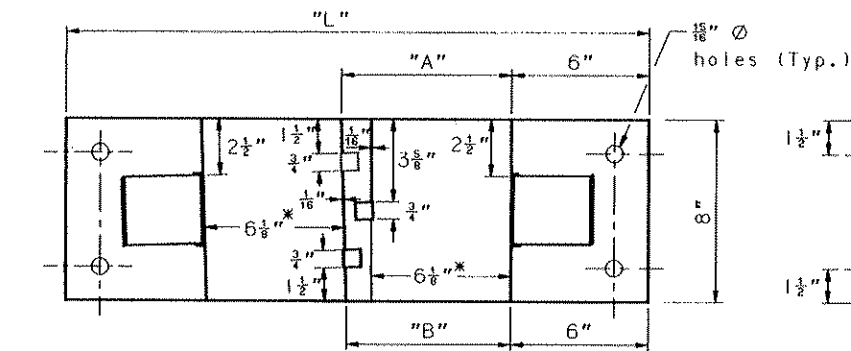

Notes:

1. Plates 8-2R/L to 8-5R/L and 10-2R/L to 10-5R/L have a "hand" and must be fabricated for either a LH or RH turnout.
2. Each plate shall be marked with deeply cut characters not less than 1/2" high. First number is turnout frog number, second is number of lies from heel block plates which count as one.
3. Switch plates shall conform to A.R.E.A. specifications for low carbon steel plates with copper.
4. Rectangular holes for track spikes are 3/4"x1 1/2" with 1/16" under the base of rail.
5. Welds shall be made so as not to interfere with resilient fasteners. Welds shall be full penetration groove welds.

	MASSACHUSETTS BAY TRANSPORTATION AUTHORITY	RAILROAD OPERATIONS	DWG. NO. 2342
			JAN. 5, 1996
RESILIENTLY FASTENED TURNOUT PLATES NO. 8 & 10 FLOATING HEEL BLOCK TURNOUTS			ISSUE DATE
			ISSUE NO. 2

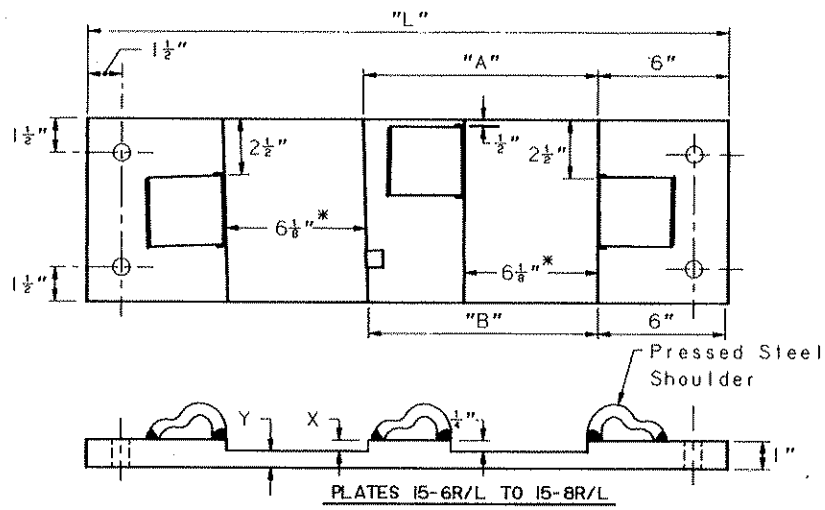

PLATES 15-6R/L TO 15-8R/L

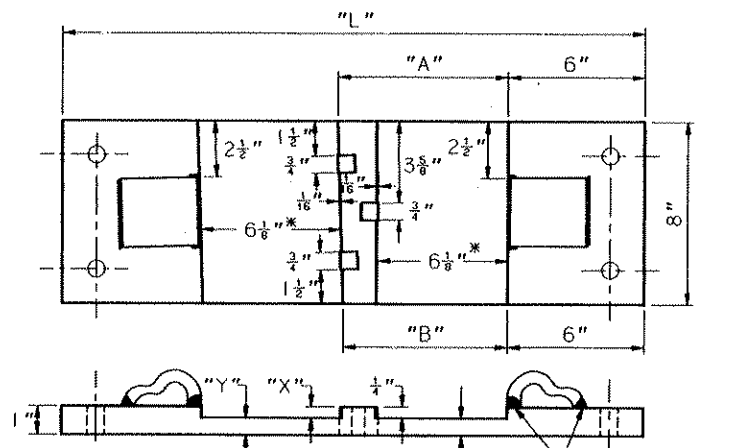

PLATES 15-3R/L TO 15-5R/L
PLATES 20-3R/L TO 20-5R/L

Welds (Typ.)
See Note 5
(Plan 2342)

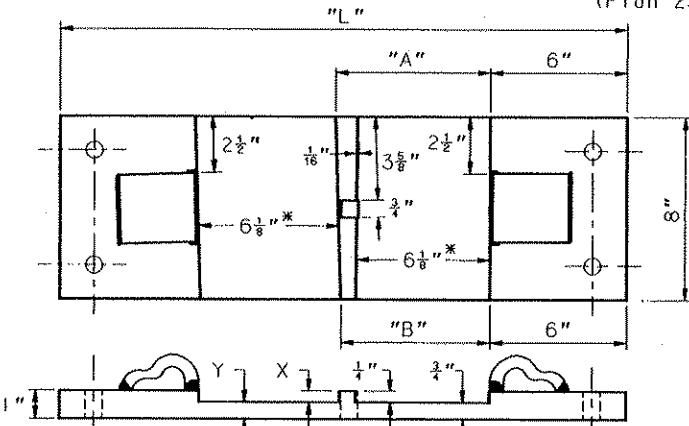

PLATES 15-2R/L & 20-2R/L

PLATE No.	A	B	X	Y	L
15-2 R/L	7 ³ / ₁₆ "	6 ³¹ / ₃₂ "	1 ³ / ₃₂ "	31 ¹ / ₃₂ "	25 ¹ / ₂ "
15-3 R/L	7 ³ / ₄ "	7 ¹⁷ / ₃₂ "	1 ¹ / ₁₆ "	15 ¹ / ₁₆ "	26"
15-4 R/L	8 ³ / ₈ "	8 ¹ / ₈ "	3 ³ / ₃₂ "	29 ³ / ₃₂ "	26 ¹ / ₂ "
15-5 R/L	8 ³¹ / ₃₂ "	8 ²³ / ₃₂ "	1 ¹ / ₈ "	7 ⁷ / ₈ "	27 ¹ / ₂ "
15-6 R/L	9 ⁵ / ₈ "	9 ¹¹ / ₃₂ "	5 ⁵ / ₃₂ "	27 ²⁷ / ₃₂ "	28"
15-7 R/L	10 ¹ / ₄ "	10"	3 ¹ / ₁₆ "	13 ¹ / ₁₆ "	28 ¹ / ₂ "
15-8 R/L	10 ¹³ / ₁₆ "	10 ²¹ / ₃₂ "	7 ⁷ / ₃₂ "	25 ²⁵ / ₃₂ "	29"
20-2 R/L	6 ¹⁵ / ₁₆ "	6 ²⁵ / ₃₂ "	1 ¹ / ₃₂ "	31 ¹ / ₃₂ "	25 ¹ / ₂ "
20-3 R/L	7 ¹¹ / ₃₂ "	7 ³ / ₁₆ "	1 ¹ / ₁₆ "	15 ¹ / ₁₆ "	26"
20-4 R/L	7 ²⁵ / ₃₂ "	7 ⁵ / ₈ "	3 ³ / ₃₂ "	29 ²⁹ / ₃₂ "	26 ¹ / ₂ "
20-5 R/L	8 ⁷ / ₃₂ "	8 ¹ / ₁₆ "	1 ¹ / ₈ "	7 ⁷ / ₈ "	27"
20-6 R/L	8 ¹¹ / ₁₆ "	8 ¹ / ₂ "	5 ⁵ / ₃₂ "	27 ²⁷ / ₃₂ "	27 ¹ / ₂ "
20-7 R/L	9 ¹ / ₈ "	8 ¹⁵ / ₁₆ "	3 ¹ / ₁₆ "	13 ¹ / ₁₆ "	27 ¹ / ₂ "
20-8 R/L	9 ¹³ / ₃₂ "	9 ¹³ / ₃₂ "	7 ⁷ / ₃₂ "	25 ²⁵ / ₃₂ "	28"

PLATE No.	A	B	C	L
15-9	11 ⁵ / ₈ "	11 ¹¹ / ₃₂ "	6 ³ / ₈ "	30"
15-10	12 ¹¹ / ₃₂ "	12 ¹ / ₁₆ "	6 ⁵ / ₃₂ "	30 ¹ / ₂ "
15-11	13 ³ / ₃₂ "	12 ¹³ / ₁₆ "	6 ⁵ / ₃₂ "	31 ¹ / ₂ "
15-12	13 ²⁷ / ₃₂ "	13 ⁹ / ₁₆ "	6 ⁵ / ₃₂ "	32"
15-13	14 ⁵ / ₈ "	14 ⁵ / ₁₆ "	6 ⁵ / ₃₂ "	33"
15-14	15 ⁷ / ₁₆ "	14 ²⁵ / ₃₂ "	6 ⁵ / ₃₂ "	34"
15-15	16 ¹ / ₄ "	15 ¹⁵ / ₁₆ "	6 ³ / ₁₆ "	34 ¹ / ₂ "
20-9	10 ³ / ₃₂ "	9 ³ / ₃₂ "	6 ³ / ₃₂ "	28 ¹ / ₂ "
20-10	10 ¹⁹ / ₃₂ "	10 ³ / ₈ "	6 ³ / ₃₂ "	29"
20-11	11 ³ / ₃₂ "	10 ⁷ / ₈ "	6 ³ / ₃₂ "	29 ¹ / ₂ "
20-12	11 ¹⁹ / ₃₂ "	11 ¹³ / ₃₂ "	6 ³ / ₃₂ "	30"
20-13	12 ¹ / ₈ "	11 ²⁹ / ₃₂ "	6 ³ / ₃₂ "	30 ¹ / ₂ "
20-14	12 ²¹ / ₃₂ "	12 ⁷ / ₁₆ "	6 ³ / ₃₂ "	31"
20-15	13 ³ / ₁₆ "	13"	6 ³ / ₃₂ "	31 ¹ / ₂ "
20-16	13 ²⁵ / ₃₂ "	13 ⁹ / ₁₆ "	6 ¹ / ₈ "	32"
20-17	14 ³ / ₈ "	14 ¹ / ₈ "	6 ¹ / ₈ "	32 ¹ / ₂ "
20-18	14 ¹⁵ / ₁₆ "	14 ²⁵ / ₃₂ "	6 ¹ / ₈ "	33"
20-19	15 ¹ / ₂ "	15 ⁹ / ₃₂ "	6 ¹ / ₈ "	34"
20-20	16 ³ / ₃₂ "	15 ²⁷ / ₃₂ "	6 ¹ / ₈ "	34 ¹ / ₂ "
20-21	16 ¹¹ / ₁₆ "	16 ⁷ / ₁₆ "	6 ¹ / ₈ "	35"

Notes:

- Plates 15-2R/L to 15-8R/L and 20-2R/L to 20-8R/L have a "hand" and must be fabricated for either a LH or RH turnout.
 - For additional notes, see Plan 2342.
- * 6¹/₈" for 132 & 136 RE Rail, 5³/₈" for 115 RE Rail.

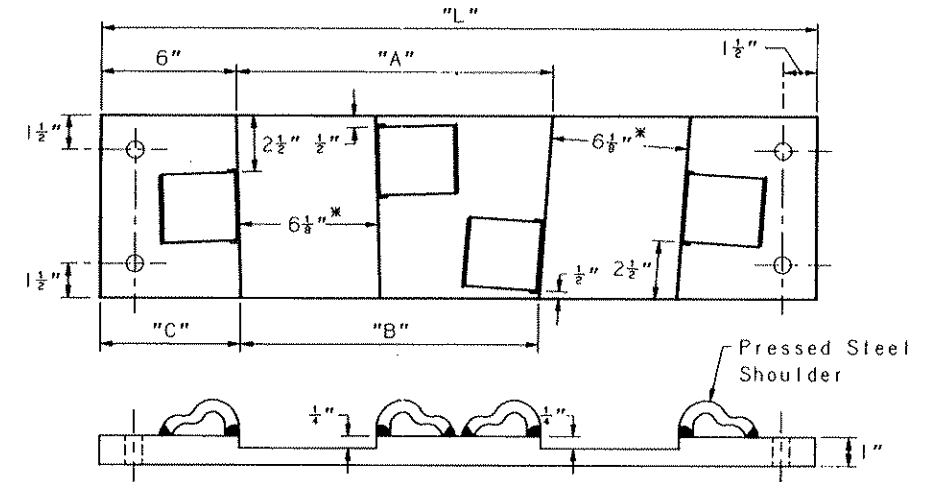

PLATES 15-9 TO 15-15
PLATES 20-11 TO 20-21

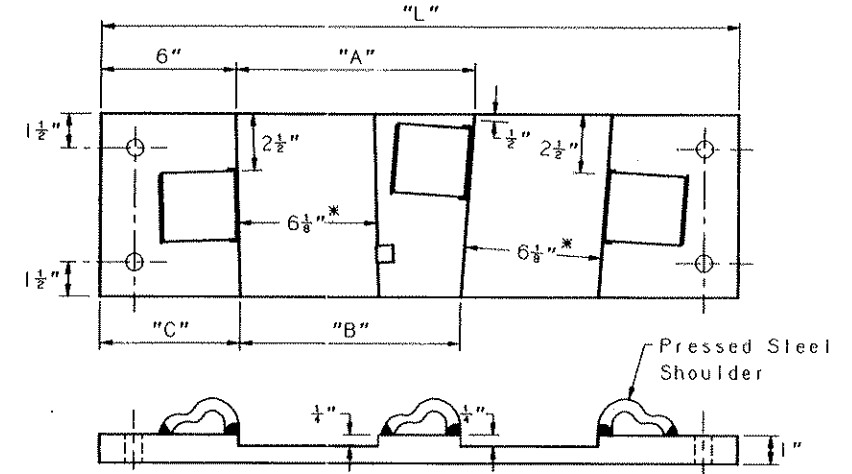

PLATES 20-9 & 20-10

	MASSACHUSETTS BAY TRANSPORTATION AUTHORITY	RAILROAD OPERATIONS	DWG. NO. 2343
			JAN. 5, 1996 ISSUE DATE
RESILIENTLY FASTENED TURNOUT PLATES NO. 15 & 20 FLOATING HEEL BLOCK TURNOUTS			(2) ISSUE NO.
			SECTION CHIEF

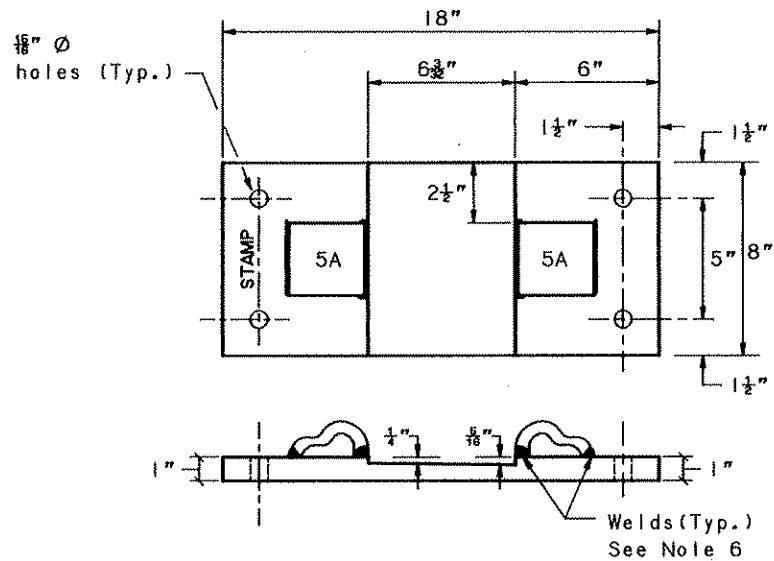

TRANSITION PLATE #TR ~ CANTED 1:80

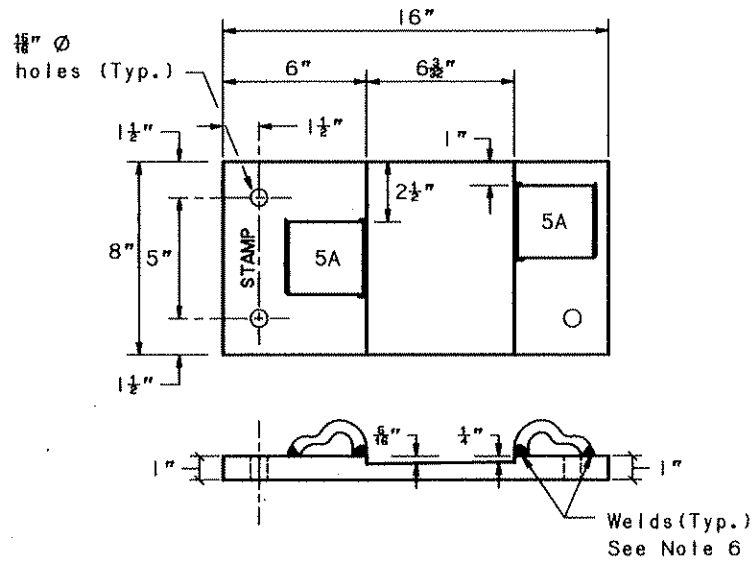

TRANSITION PLATE #TR-2 ~ CANTED 1:80

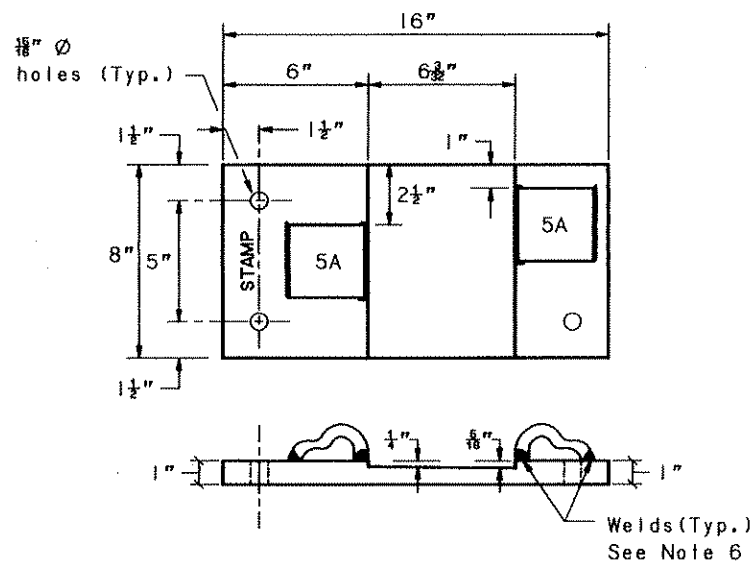

TRANSITION PLATE #TR-1 ~ CANTED 1:80

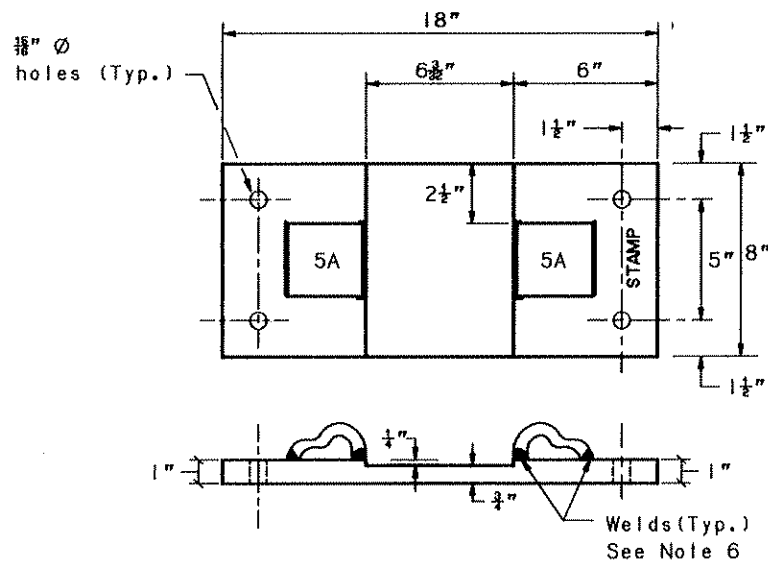

FLAT PLATE #FP

Notes:

1. All plate holding spike holes 3/8" dia.
2. All Pandrol Shoulders Type 2172-5.
3. Rail seat must be free of weld, slag and spatter.
4. Stamp each plate with its plt no., 132RE where indicated.
5. Stamp turnout plates on alternate ends of plates so that the mark will always be on the field side.
6. Welds shall be full penetration groove welds on shoulder and full penetration fillet welds on stops. (3/8")
7. FP Plates to be used where rail joint falls in transition area.

 MASSACHUSETTS BAY TRANSPORTATION AUTHORITY	RAILROAD OPERATIONS	DWG. NO. 2348
		JAN. 5, 1986 <small>ISSUE DATE</small>
SPECIAL FLAT AND TRANSITION CANTED PLATES		
 <small>SECTION CHIEF</small>		

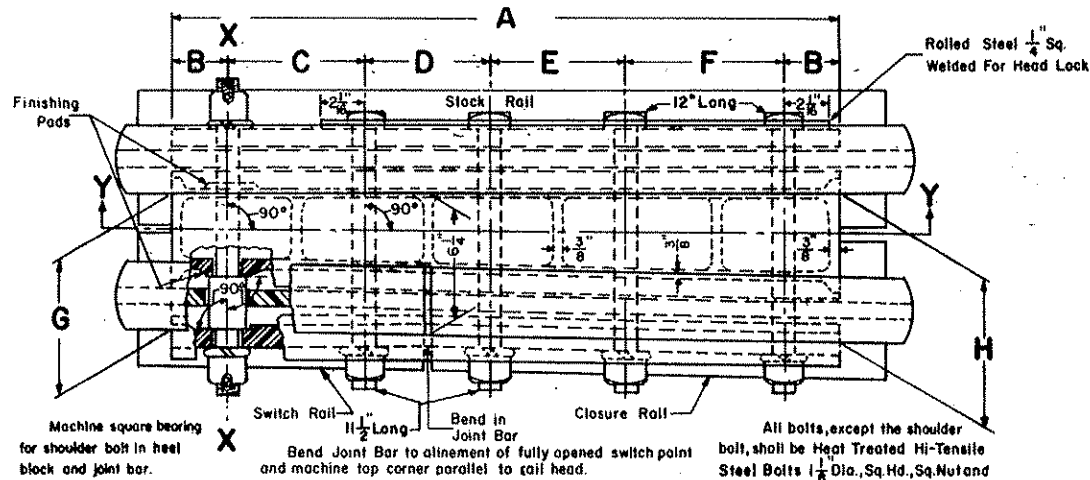

HEEL BLOCK ASSEMBLY

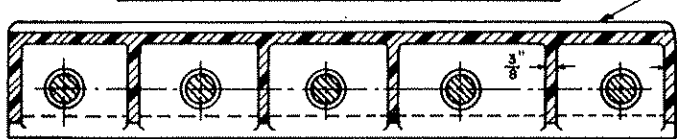

SECTION Y-Y
CAST STEEL, CLASS B-HARD OR DUCTILE IRON)

Mark top of heel block with raised letters showing the following:-
Length of Switch Rail Section
Example: 16'-6", 132

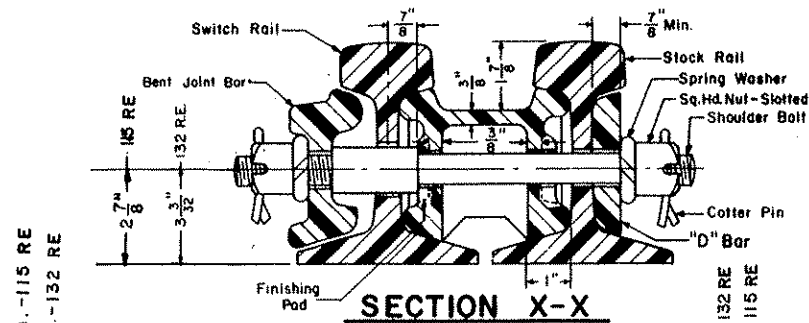

SECTION X-X

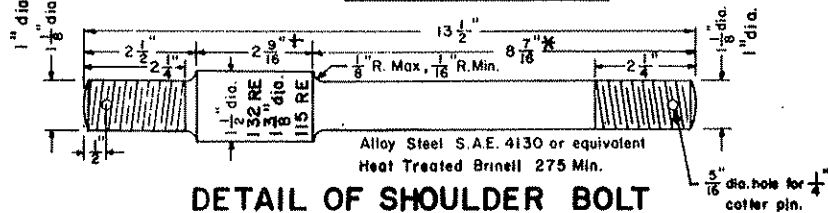

DETAIL OF SHOULDER BOLT

+ 2 23/32" * 8 9/32" - FOR 115 RE

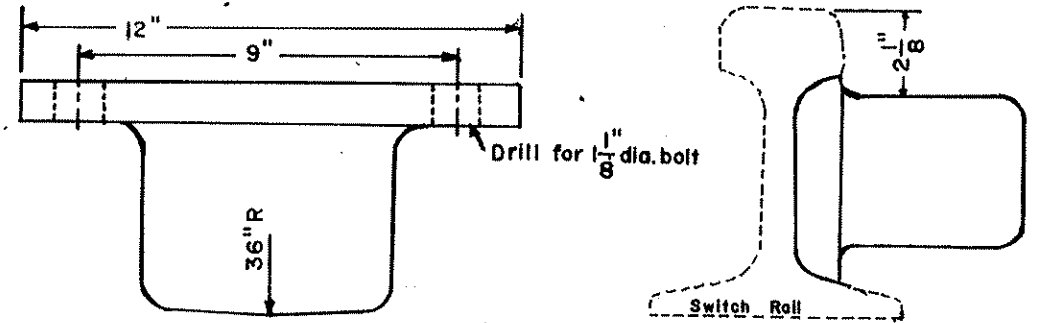

TOP VIEW

SIDE VIEW

FLOATING HEEL BLOCK

HEEL BLOCK DIMENSIONS

SWITCH LENGTH and RAIL SECTION	HEEL BLOCK LENGTH	BOLT HOLE SPACINGS					TOE END SPREAD	HEEL END SPREAD
		A	B	C	D	E		
39'-115 RE	30"	27 7/16"	6"	7 7/8"	6"	6"	6 1/32"	6 19/32"
39'-132 RE	"	"	"	"	"	"	6 1/32"	6 19/32"
26'-115 RE	"	"	"	"	"	"	5 15/16"	6 11/16"
26'-132 RE	"	"	"	"	"	"	5 15/16"	6 11/16"
16'-6" 115 RE	"	"	"	"	"	"	5 23/32"	6 13/16"
16'-6" 132 RE	"	"	"	"	"	"	5 23/32"	6 13/16"
11'-115 RE	"	"	"	"	"	"	6 3/4"	7"
11'-132 RE	"	"	"	"	"	"	6 3/4"	7"

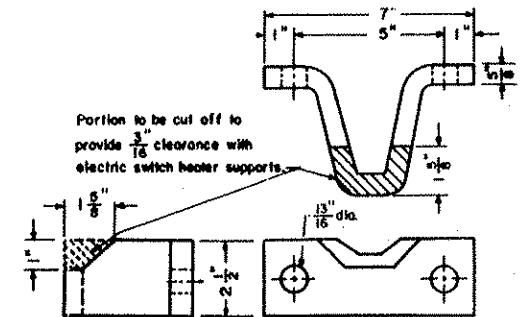

SWITCH RAIL STOP

MASSACHUSETTS BAY TRANSPORTATION AUTHORITY	RAILROAD OPERATIONS	DWG. NO. 2350
		Oct. 28, 1992
		ISSUE DATE 2 ISSUE NO.

HEEL BLOCK AND SWITCH RAIL STOP

11', 16'-6", 26' & 39' SWITCHES - 115 R.E. & 132 R.E. RAIL

ENGINEERING OFFICER CHIEF ENGINEERING OFFICER

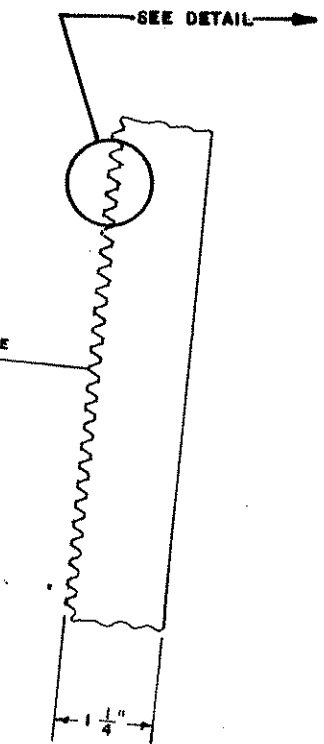
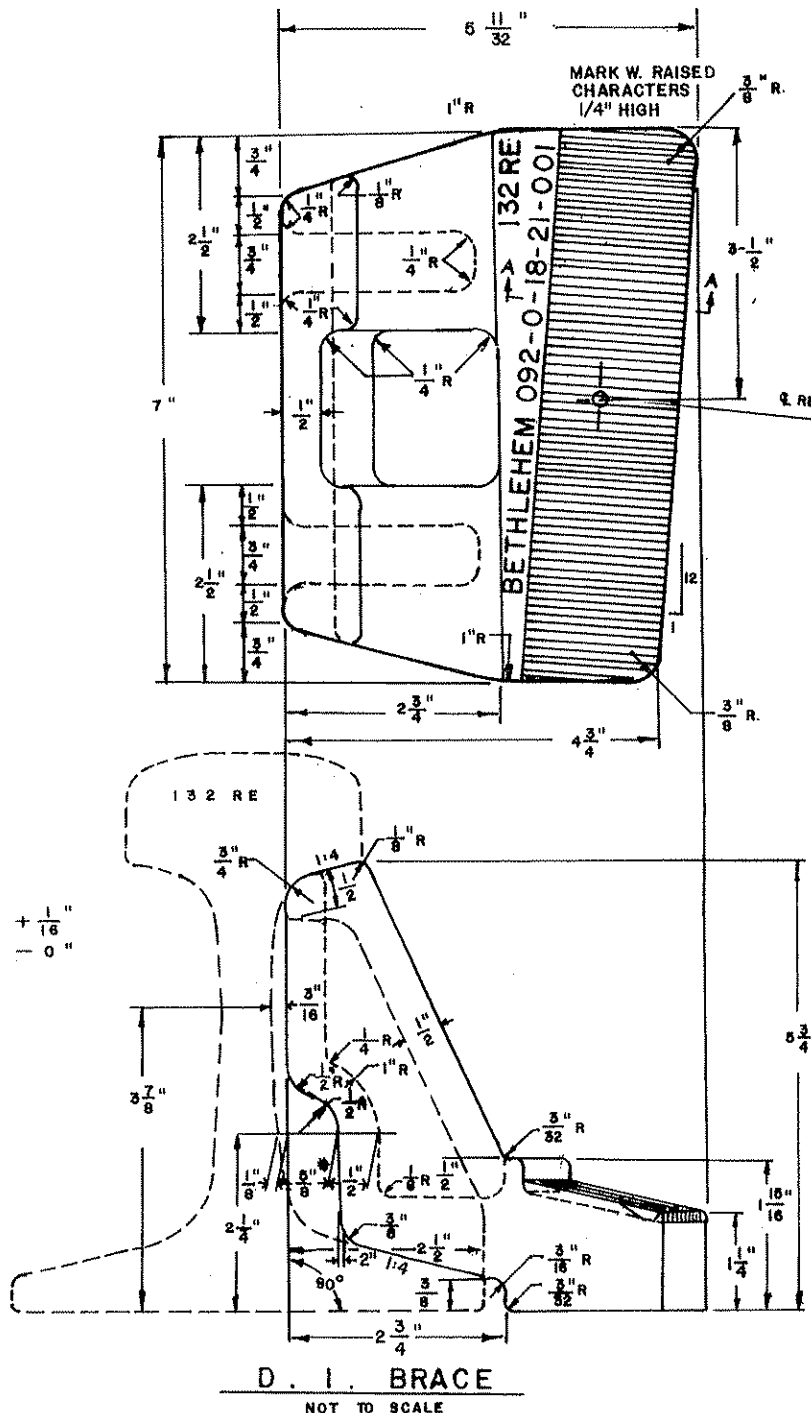

END VIEW
NOT TO SCALE

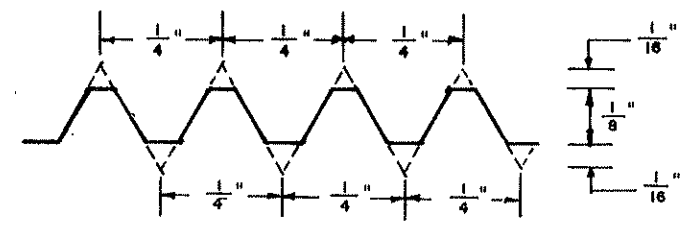

DETAIL OF SERRATIONS

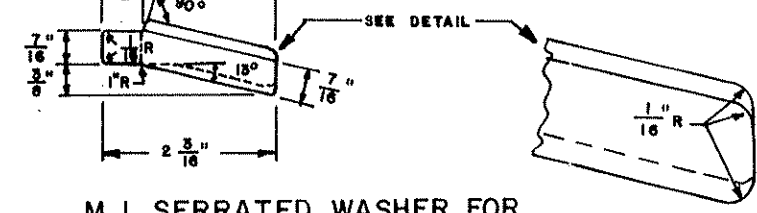
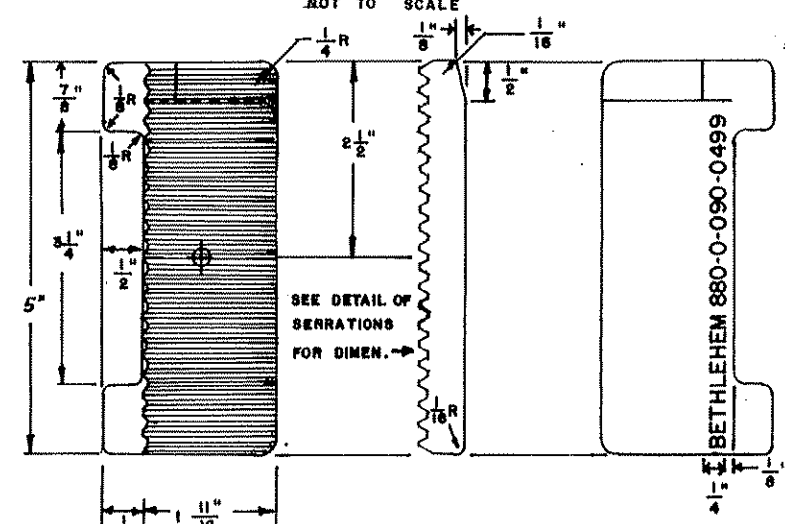

M. I. SERRATED WASHER FOR
PLATE BASE

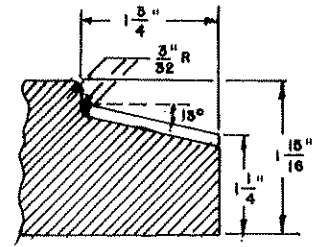

SECTION A-A
NOT TO SCALE

MATERIAL	
D. I.	DUCTILE IRON
M. I.	MALEABLE IRON

* + 1/16"
- 0"

THIS BRACE IS A PATENTED DESIGN
OF BETHLEHEM STEEL CORP.

	MASSACHUSETTS BAY TRANSPORTATION AUTHORITY	RAILROAD OPERATIONS	DWG. NO. 2352
			6-5-87
			ISSUE DATE
			ISSUE NO. 2

RESILIENTLY FASTENED
ADJUSTABLE RAIL BRACE

David Brown ENGINEERING OFFICER
W. A. ... CHIEF ENGINEERING OFFICER

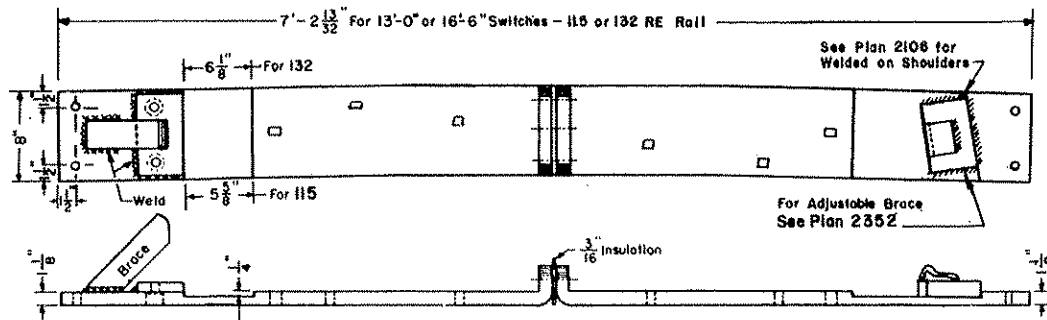

GAGE PLATE "16"-INSULATED

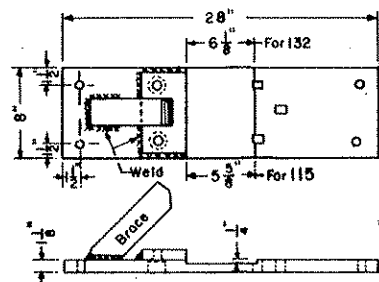

SLIDE PLATE "SP"

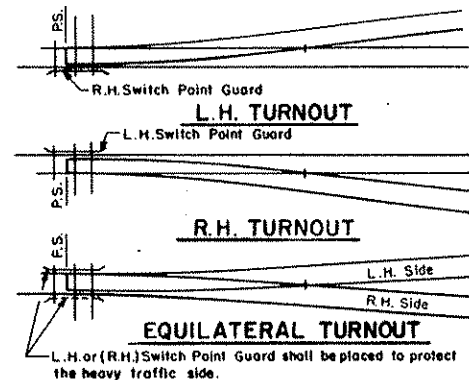

NOTE:
All switch point guards are located to protect the diverging point.

SWITCH POINT GUARD DESIGNATIONS

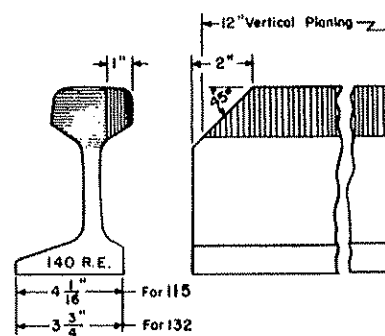

PLANING OF GUARD ENDS

Manufactured By Pettibone-Ohio
(Formerly Cleveland Frog & Crossing Co.)

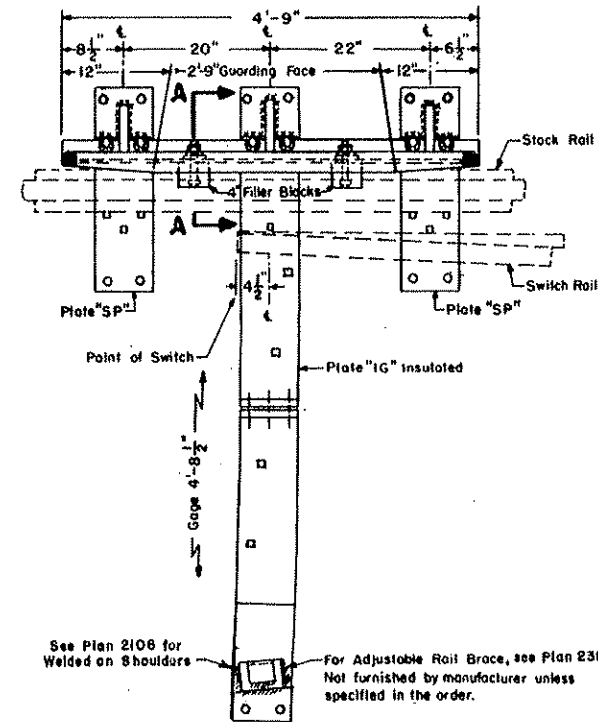

PLAN

R.H. Turnout As Shown

NOTES

- 1 - All plates to be open hearth mild steel
- 2 - All guard rails heat treated and oil quenched to a Brinell Hardness of 321 to 375.
- 3 - All plates to be stamped with plate designation and rail section. The gage plate to be also stamped with hand and length of switch rail.
- 4 - When a non-insulated gage plate is required, the gage plate shall be furnished solid.
- 5 - When ordering switch point guard specify weight of rail, length of switch rail and hand.
- 6 - All plate holding screw lag holes shall be 15/16" dia. to accommodate 7/8" screw lags.

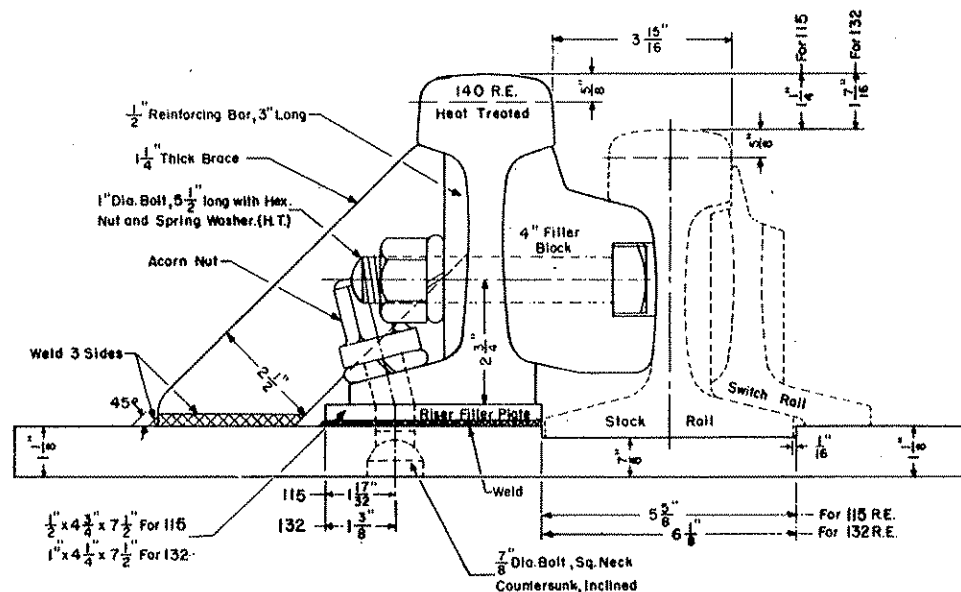

SECTION A-A (TYPICAL)

T	MASSACHUSETTS BAY TRANSPORTATION AUTHORITY	RAILROAD OPERATIONS	DWG. NO. 2356
			Oct. 28, 1992 ISSUE DATE
		(2)	ISSUE NO.

SWITCH POINT GUARD

FOR 11' or 16'-6" SWITCHES - 115 or 132 RAIL

1 John D. Ray
ENGINEERING OFFICER

W. A. [Signature]
CHIEF ENGINEERING OFFICER

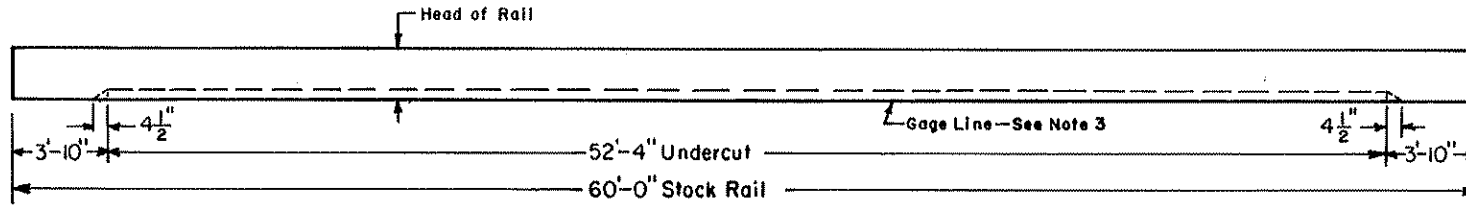

NO HAND
60 FT. UNDERCUT STOCK RAIL

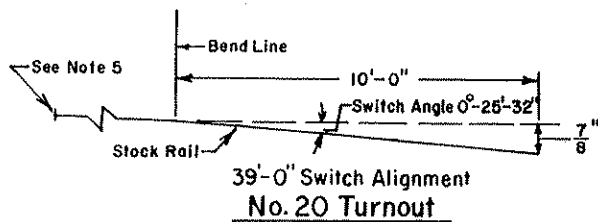
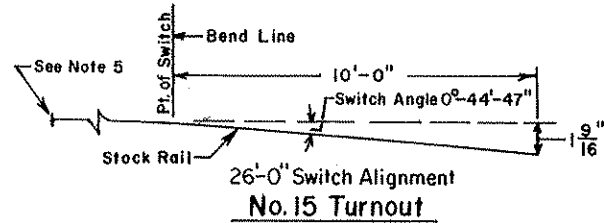
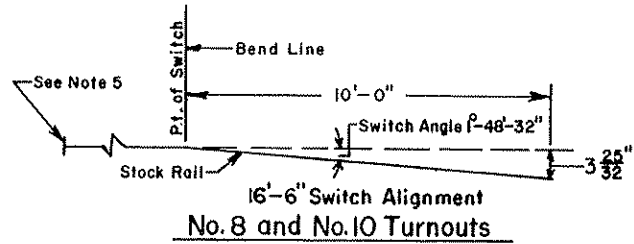

BENDING OF STOCK RAILS

(See Notes 4 & 5)

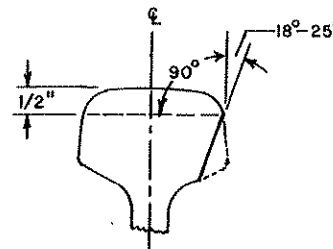

DETAIL OF UNDERCUT

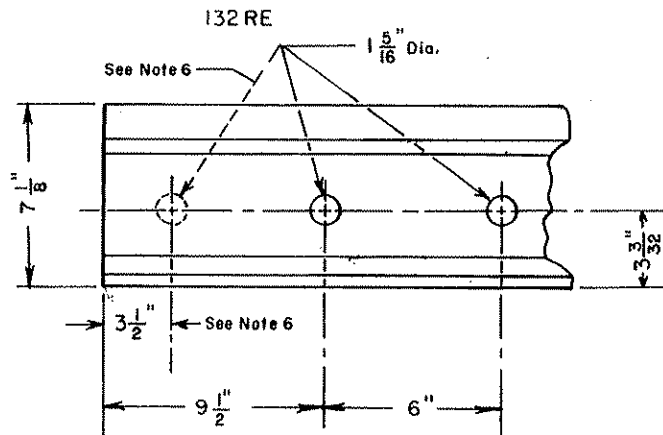

NOTES:

1. Rail to conform to current MBTA specifications.
2. Stock rails to be fully heat treated.
3. Undercut to be on the opposite side of the rail brand.
4. Stock rails are to be bent and curved to the alignment specified on this Plan
5. Initial bend line location of stock rail will vary according to the distance the stock rail is placed ahead of the point of switch. The distance ahead of the point of switch to the end of the stock rail shall conform to MBTA Standard Plans: -

Turnout No.	Drawing No.	Switch Alignment	Stock Rails Ahead of Point	
			Straight	Curved
10	2112	16'-6"	10'-5"	14'-7 1/2"
15	2162	26'-0"	8'-9 1/4"	5'-0"
20	2212	39'-0"	9'-0 1/2"	5'-7 1/2"

6. When stock rail ends are not to be field welded, the first bolt hole shall be drilled in the field by Installer.
7. For offsets for curving 60'-0" stock rails, see standard turnout plans. (Drawing No.'s are listed in table above.)

T	MASSACHUSETTS BAY TRANSPORTATION AUTHORITY	RAILROAD OPERATIONS	DWG. NO. 2360
			Oct. 28, 1992 ISSUE DATE

60 FT. UNDERCUT STOCK RAIL

John D. Ray
ENGINEERING OFFICER

W. A. ...
CHIEF ENGINEERING OFFICER

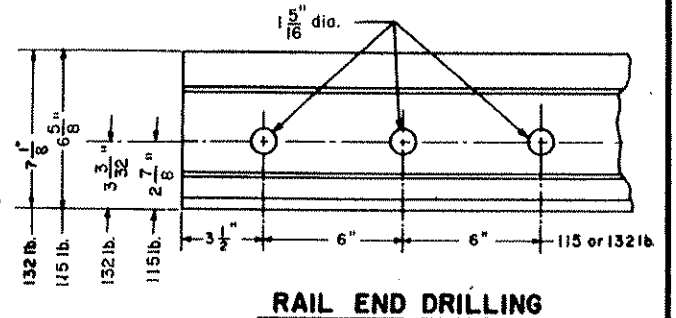
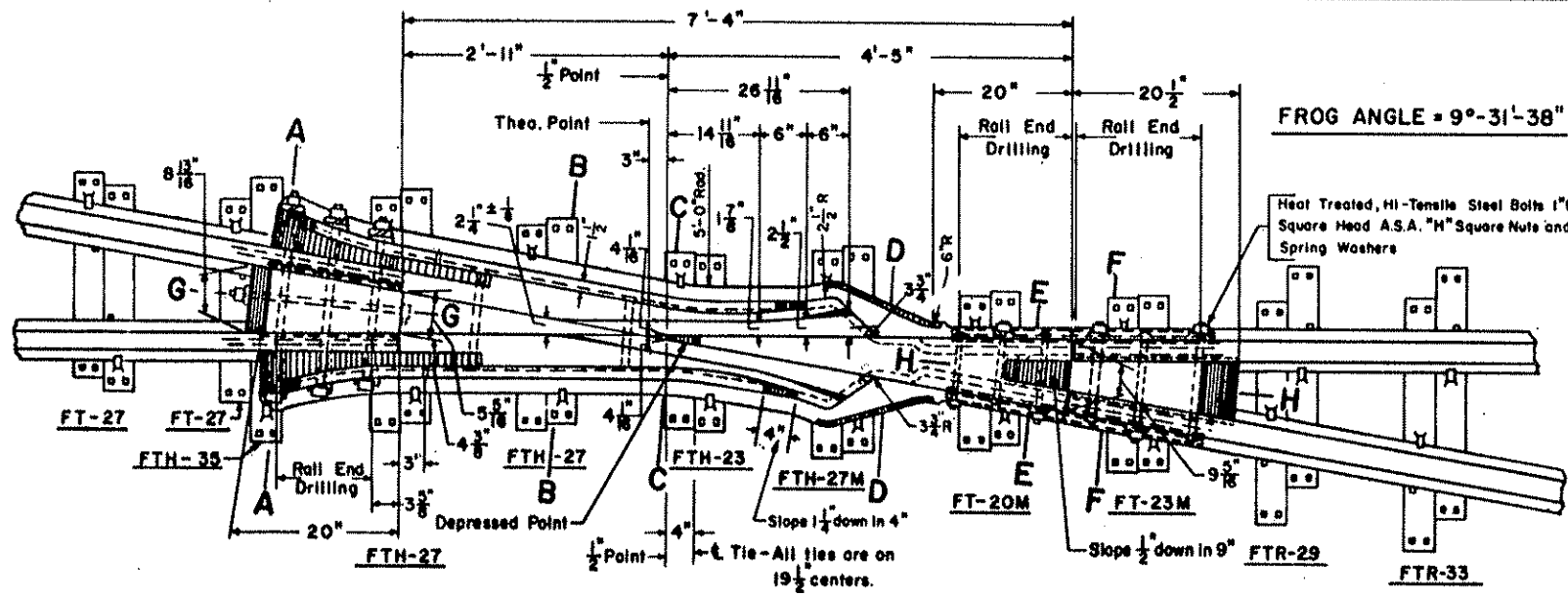

FROG TIE PLATES REQUIRED

- 2 - FT 20 Mod
- 2 - FT 23 Mod.
- 3 - FT 27
- 2 - FTH 23
- 4 - FTH 27
- 2 - FTH 27 Mod.
- 1 - FTH 35
- 2 - FTR 29
- 2 - FTR 33

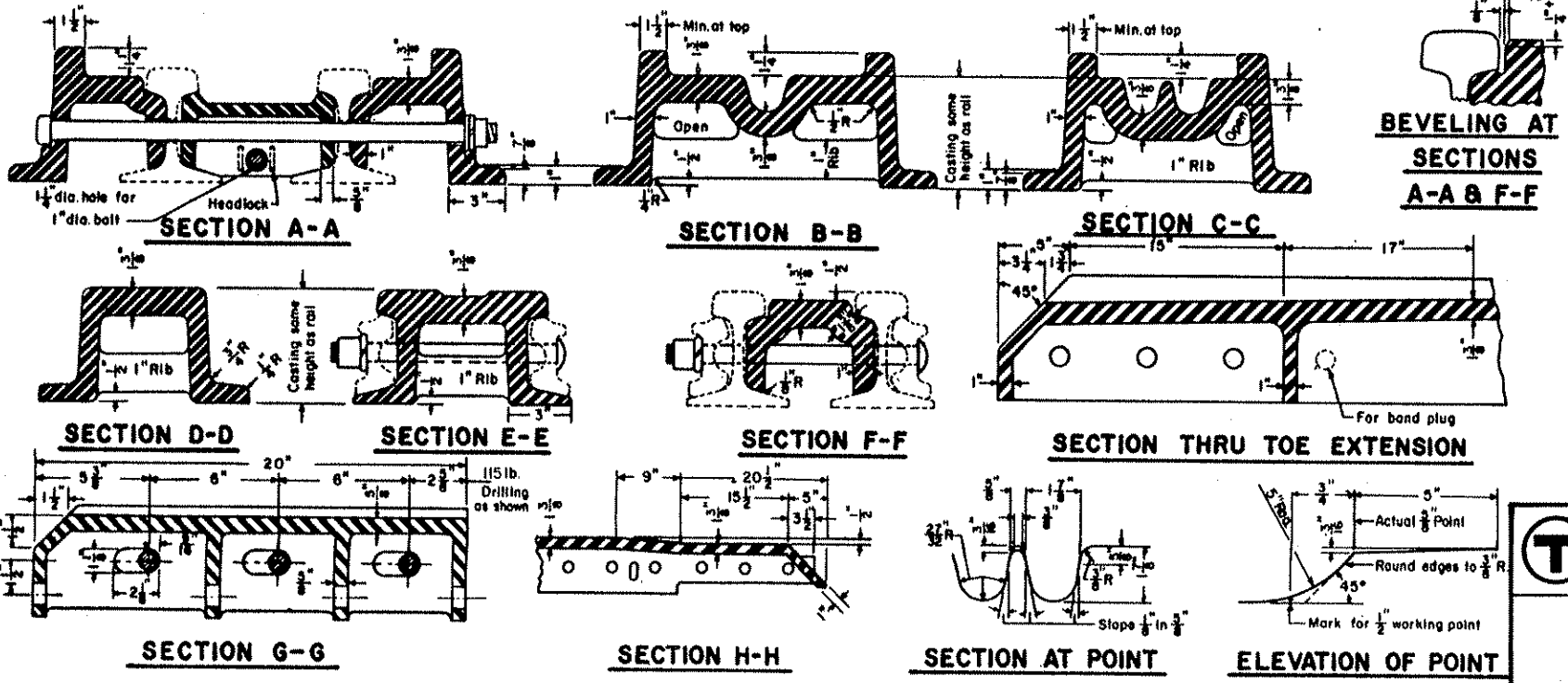

BEVELING AT SECTIONS A-A & F-F

NOTES

- 1 - This plan is for use with A.R.E.A. recommended standards for 115 RE., 132 RE.
- 2 - Workmanship and materials shall be as per current "A.R.E.A. Specifications."
- 3 - All bolts shall be dipped immediately before applying (so that all the threads are thoroughly coated) with Grease.
- 4 - All frog tie plates must be clearly marked to show plate designation

T	MASSACHUSETTS BAY TRANSPORTATION AUTHORITY	RAILROAD OPERATIONS	DWG. NO. 2370
			Oct. 28, 1992 1
		ISSUE DATE	ISSUE NO.

NO. 6 SOLID SELF-GUARDED MANGANESE STEEL FROG

John D. Pray ENGINEERING OFFICER *W. A. ...* CHIEF ENGINEERING OFFICER

DIMENSIONS OF RAISED GUARDS						
RAIL SEC.	ANGLE-a	ANGLE-b	D	C	L	B
115 lb.	0°-34'-40"	7°-45'-00"	8'-0 1/2"	22 1/2"	8'-7"	7 1/2"
132 lb.						

FORMULA FOR VARIABLE RADIUS OF RAISED GUARDS

TAN ANGLE b = 5/16" / L
 ANGLE a = ANGLE b + FROG ANGLE
 D = TOE SPREAD + 4-3/8"
 C = 3" / SIN a
 B = D - (L + C)
 RADIUS = B / TAN a/2

STRAIGHT CROSS RIBS
 SPACED APPROXIMATELY
 18" CENTER TO CENTER.

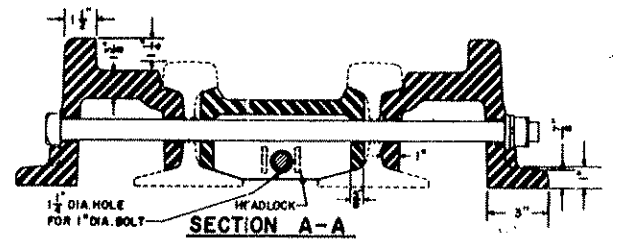
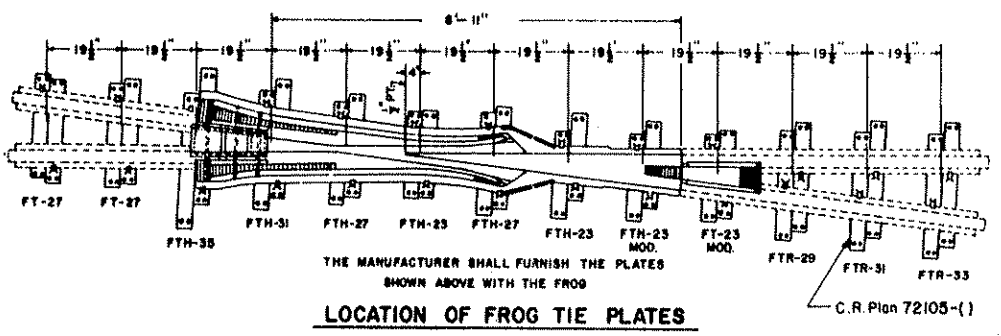
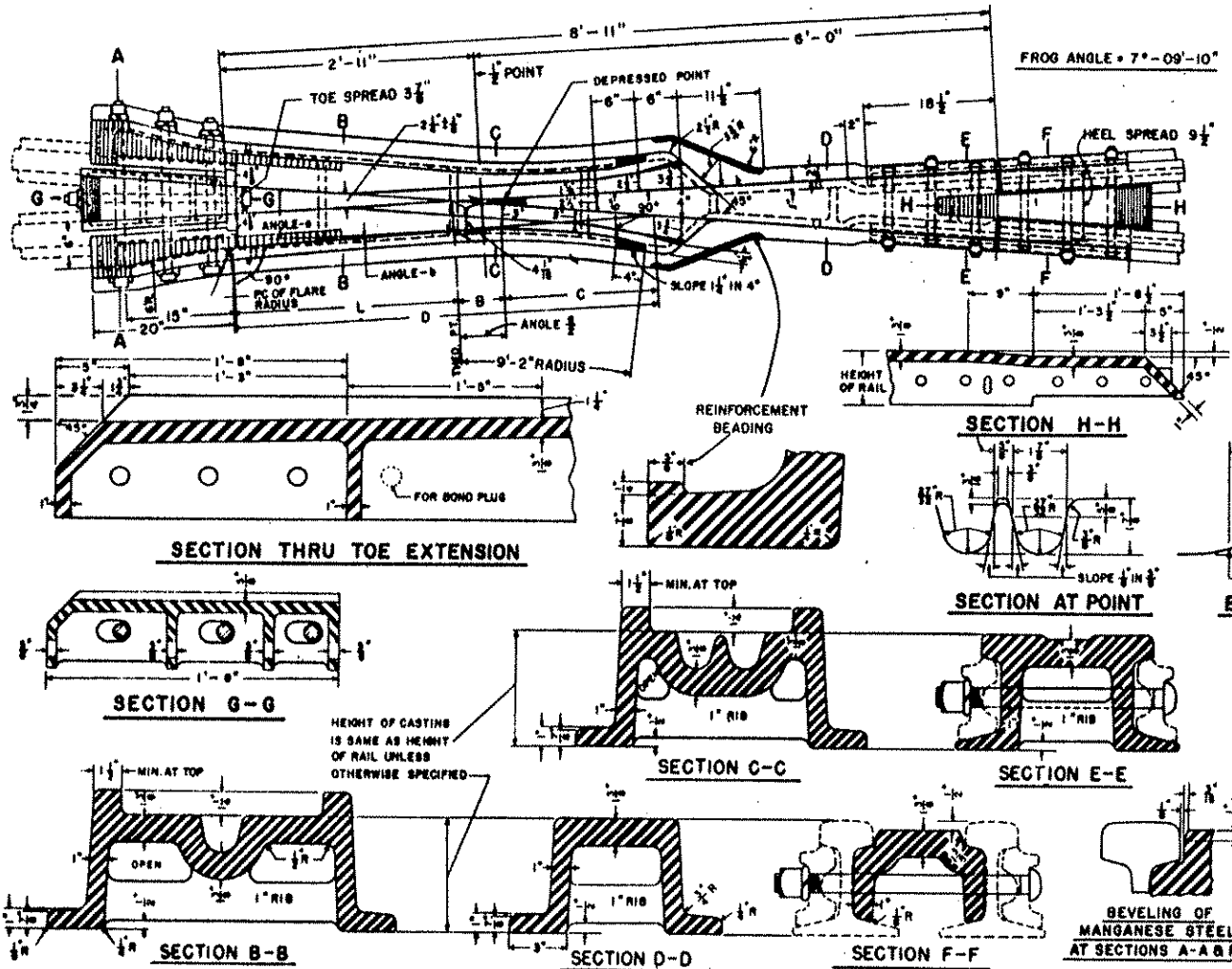

SECTION THRU TOE EXTENSION



SECTION G-G

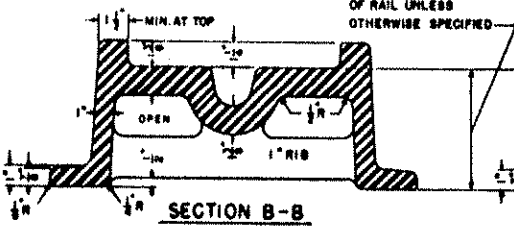

SECTION B-B

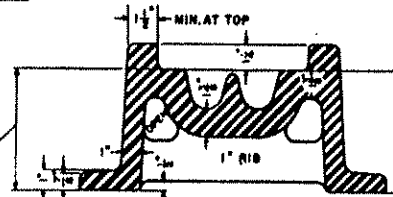

SECTION C-C

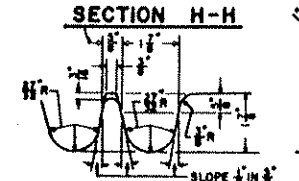

SECTION H-H

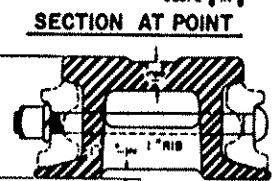

SECTION AT POINT

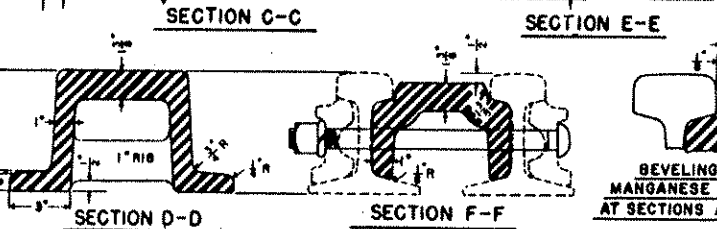

SECTION E-E

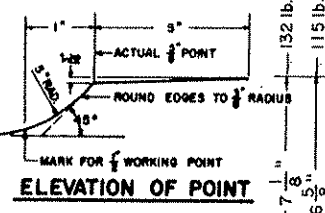

ELEVATION OF POINT

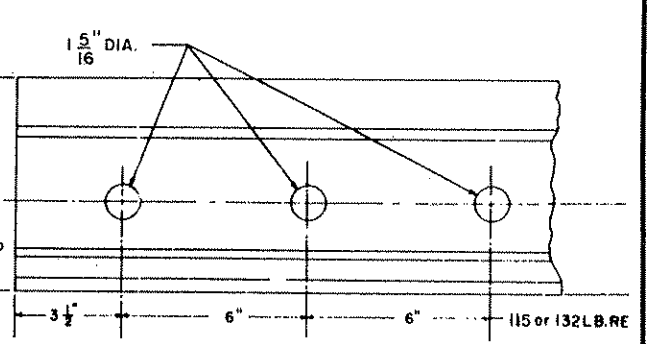

RAIL END DRILLINGS

FROG TIE PLATES REQUIRED

- 2 - FT-23 MOD. FROG TIE PLATES
- 4 - FTH-23 FROG TIE PLATES
- 2 - FTH-23 MOD. FROG TIE PLATES
- 4 - FT-27 FROG TIE PLATES
- 4 - FTH-27 FROG TIE PLATES
- 2 - FTR-29 FROG TIE PLATES
- 2 - FTH-31 FROG TIE PLATES
- 2 - FTR-31 FROG TIE PLATES
- 2 - FTR-33 FROG TIE PLATES
- 2 - FTH-35 FROG TIE PLATES

NOTES

1 - THIS PLAN IS FOR USE WITH A.R.E. RECOMMENDED STANDARDS FOR 115 R.E., 132 R.E.

2 - WORKMANSHIP AND MATERIALS SHALL BE PER CURRENT "A.R.E. SPECIFICATIONS."

3 - ALL BOLTS SHALL BE DIPPED IMMEDIATELY BEFORE APPLYING (SO THAT ALL THREADS ARE THOROUGHLY COATED) WITH GREASE.

4 - ALL FROG TIE PLATES MUST BE CLEARLY MARKED TO SHOW PLATE DESIGNATION.

T	MASSACHUSETTS BAY TRANSPORTATION AUTHORITY	RAILROAD OPERATIONS	DWG. NO. 2372
			Oct. 28, 1992
			ISSUE DATE

NO. 8 SOLID SELF-GUARDED MANGANESE STEEL FROG

John D. Reay
 ENGINEERING OFFICER

W. A. ...
 CHIEF ENGINEERING OFFICER

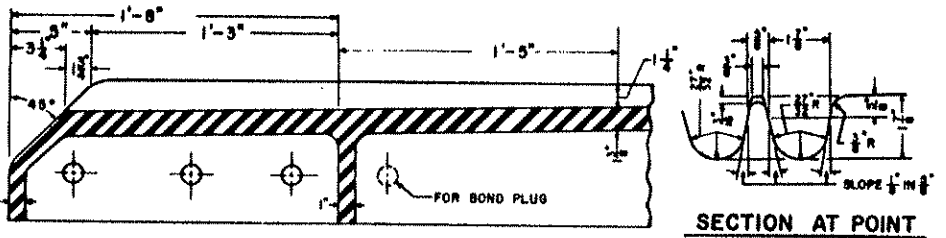

SECTION THRU TOE EXTENSION

SECTION AT POINT

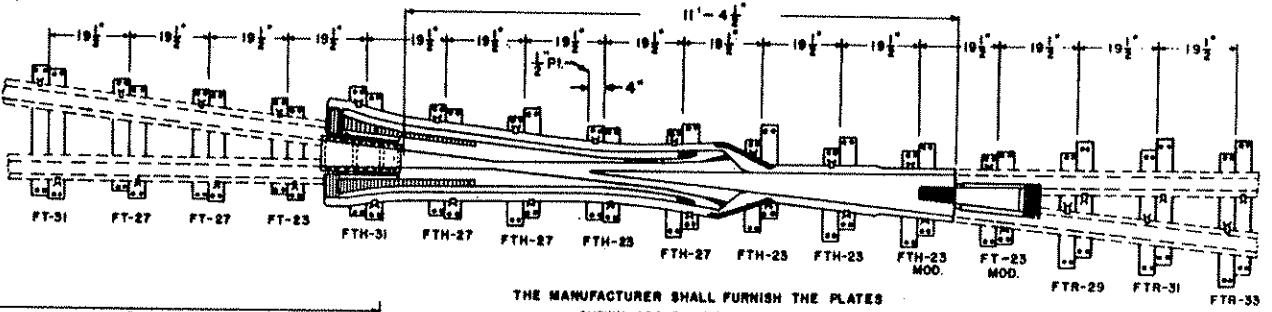

THE MANUFACTURER SHALL FURNISH THE PLATES SHOWN ABOVE WITH THE FROG

LOCATION OF FROG TIE PLATES

FROG ANGLE = 5°-43'-29"

HEEL SPREAD 9 1/2"

FROG TIE PLATES REQUIRED

- 2 - FT 23 FROG TIE PLATES
- 2 - FT 23 MOD. FROG TIE PLATES
- 4 - FT 27 FROG TIE PLATES
- 2 - FT 31 FROG TIE PLATES
- 6 - FTH 23 FROG TIE PLATES
- 2 - FTH 23 MOD FROG TIE PLATES
- 6 - FTH 27 FROG TIE PLATES
- 2 - FTH 31 FROG TIE PLATES
- 2 - FTR 29 FROG TIE PLATES
- 2 - FTR 31 FROG TIE PLATES
- 2 - FTR 33 FROG TIE PLATES

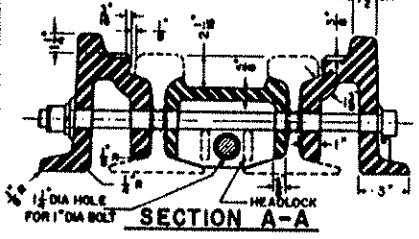
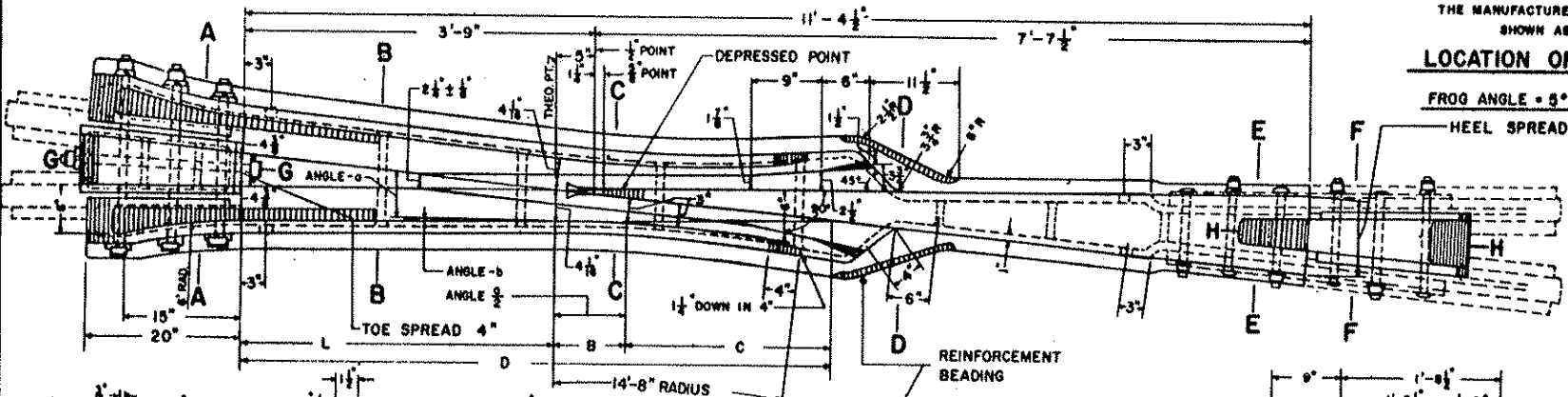

SECTION A-A

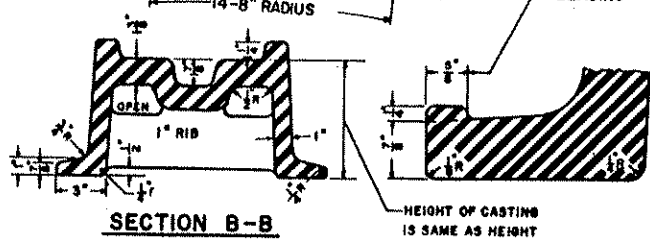

SECTION B-B

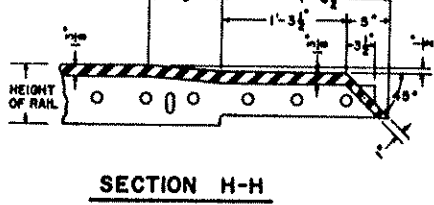

SECTION H-H

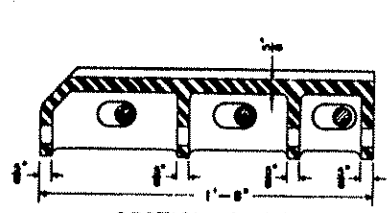

SECTION G-G

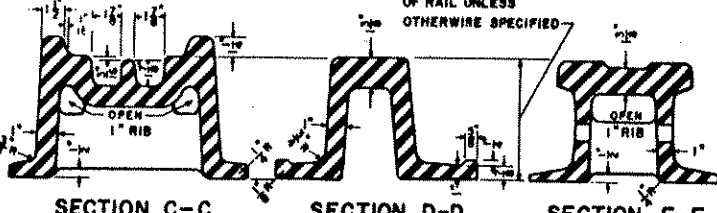

SECTION C-C

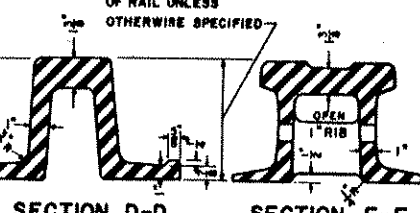

SECTION D-D

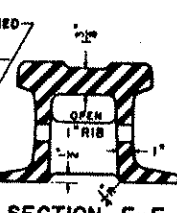

SECTION E-E

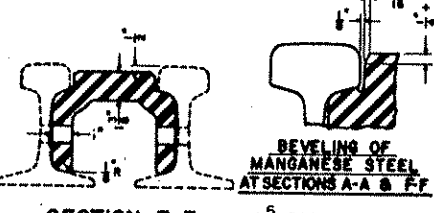

SECTION F-F

DIMENSIONS OF RAISED GUARDS						
RAIL SEC.	ANGLE - b	ANGLE - a	D	C	L	B
115 LB.	0°-20'-00"	0°-10'-15"	0'-5 3/16"	2'-3 3/16"	3'-4"	9 1/2"
132 LB.						

FORMULA FOR VARIABLE RADIUS OF RAISED GUARDS

$TAN \text{ ANGLE } a = \frac{D}{C}$
 $ANGLE \ a = \text{ANGLE } b + \text{FROG ANGLE}$
 $D = \text{TOE SPREAD} + 4 \frac{1}{2}$
 $C = \frac{D}{TAN \ a}$
 $B = D - (L + C)$
 $RADIUS = \frac{D}{TAN \ a}$

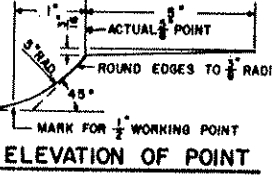

ELEVATION OF POINT

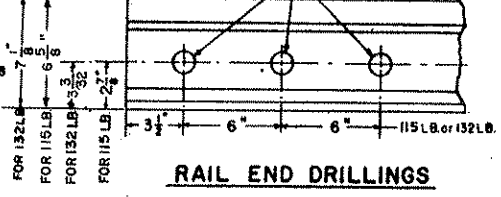

RAIL END DRILLINGS

NOTES

- 1 - THIS PLAN IS FOR USE WITH A.R.E.A. RECOMMENDED STANDARDS FOR 115 R.E., 132 R.E.
- 2 - WORKMANSHIP AND MATERIALS SHALL BE PER CURRENT A.R.E.A. SPECIFICATION.
- 3 - ALL BOLTS SHALL BE DIPPED IMMEDIATELY BEFORE APPLYING (SO THAT ALL THREADS ARE THOROUGHLY COATED) WITH GREASE.
- 4 - ALL FROG TIE PLATES MUST BE CLEARLY MARKED TO SHOW PLATE DESIGNATION.

MASSACHUSETTS BAY TRANSPORTATION AUTHORITY	RAILROAD OPERATIONS	DWG. NO. 2374
		Oct. 28, 1992 ISSUE DATE

NO. 10 SOLID SELF-GUARDED MANGANESE STEEL FROG

John D. Ray ENGINEERING OFFICER
 [Signature] CHIEF ENGINEERING OFFICER

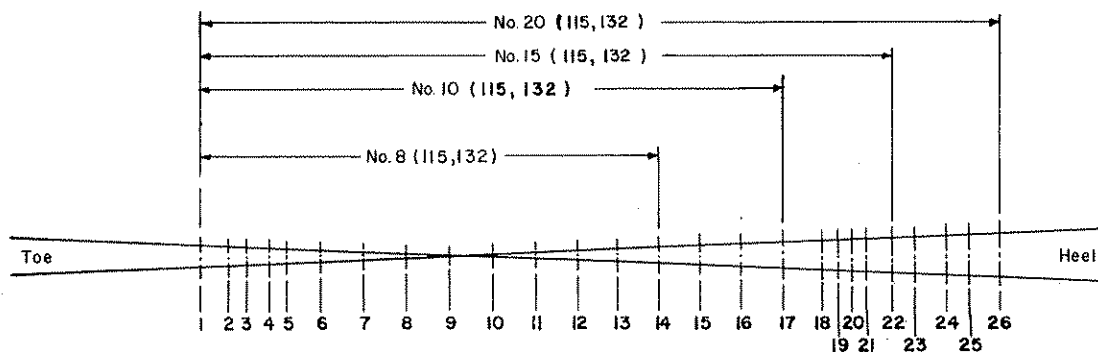

BOLT LOCATIONS

BOLT LENGTHS

FROG NO.	RAIL SECT.	PLAN NO.	BOLTS NUMBERED IN ORDER FROM TOE TO HEEL OF FROG																									
			1	2	3	4	5	6	7	8	9	10	11	12	13	14	15	16	17	18	19	20	21	22	23	24	25	26
			LENGTH "L" UNDER HEAD (INCHES)																									
8	115	2084	11	11	10	13	15	16	15	15	16	17	18	19	20	12												
	132		12	11	11	13	15	16	15	16	17	18	19	20	20	12												
10	115	2105	11	11	11	12	14	16	15	14	15	16	17	18	19	19	11	11	12									
	132		11	11	11	12	14	16	15	15	16	17	18	19	20	20	11	13	13									
15	115	2156	11	11	11	10	10	12	13	16	17	18	16	15	16	17	18	18	19	19	19	10	11	11				
	132		12	11	11	11	12	14	16	17	18	18	16	16	17	18	18	19	19	19	20	11	11	13				
20	115	2206	11	11	10	10	10	13	15	16	16	17	18	16	15	15	16	17	18	18	19	19	19	10	10	11	11	12
	132		11	11	10	10	10	13	15	16	16	17	18	16	15	15	16	17	18	18	19	19	19	10	10	11	11	12

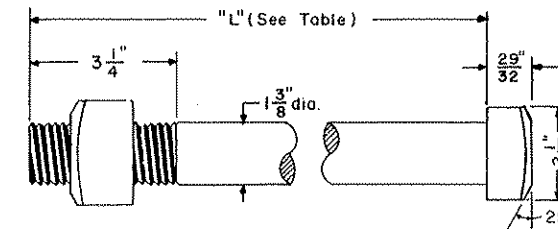

(Square Head)
FROG BOLT

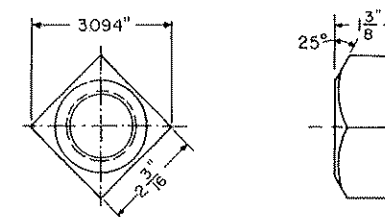

SQUARE NUT

NOTES

- 1 - Bolts and nuts shall conform to current AREA Specifications for special trackwork, Article 11, and details shown on this plan.
Bolts and nuts per A.S.A.-B18.2.2-1965
Threads - A.S.A.-B11-1960 Class 2 Fit, Coarse Thread Series with cut threads.
- 2 - All nuts to be wrench fit and Medium Carbon Steel.
(0.40 Minimum - 0.55 Maximum)
- 3 - Bolts shall be 1 3/8" dia.

T	MASSACHUSETTS BAY TRANSPORTATION AUTHORITY	RAILROAD OPERATIONS	DWG. NO. 2502	① ISSUE NO.
			Oct. 28, 1992 ISSUE DATE	
REPLACEMENT BOLTS FOR RAILBOUND MANGANESE FROGS				
<i>John D. Ray</i> ENGINEERING OFFICER		<i>W. A. B. Gould</i> CHIEF ENGINEERING OFFICER		

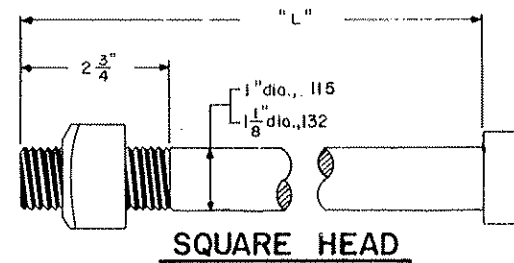

SQUARE HEAD

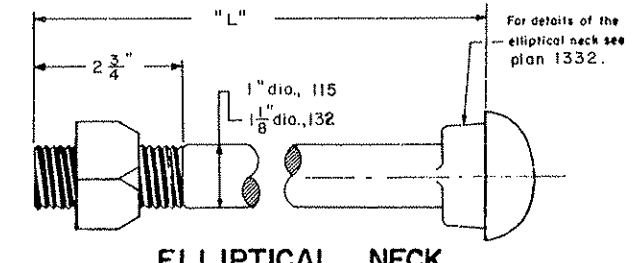

ELLIPTICAL NECK

FROG BOLTS

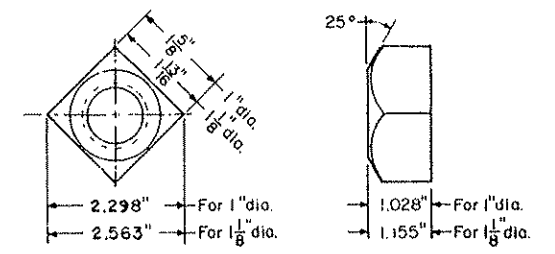

HEAVY SQUARE NUT

NOTES

- 1-Bolts and nuts shall conform to current A.R.A. Specifications for special trackwork, Article 14 and details shown on this plan:-
Bolts and nuts per A.S.A.-B18.2.2-1965
Threads-A.S.A.-B1.1-1960 Class 2 Flt, Coarse Threads Series with cut threads.
- 2-All nuts to be wrench fit.
- 3-Bolts for frogs 115 lbs. or lighter shall be 1" diameter;
Bolts for frogs heavier than 115 lbs. shall be 1 1/8" diameter.

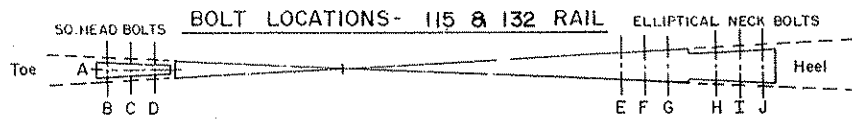

BOLT LENGTHS FOR FROG NOS. 6, 8 & 10- 115 & 132 LB. RAIL

FROG NO.	RAIL SECTION	BOLT DIA.	BOLTS LETTERED IN ORDER-TOE TO HEEL OF FROG										
			SQUARE HEAD				ELLIPTICAL NECK						
			A	B	C	D	E	F	G	H	I	J	
			LENGTH "L" UNDER HEAD (INCHES)										
6	115	1"	24	26	24	21	10	11	12	13	14	15	
8			24	25	22	20	12	12	13	14	14	15	
10			25	25	22	20	12	12	13	14	14	15	
6	132	1 1/8"	24	26	24	21	10	11	12	14	14	15	
8			24	25	22	20	12	13	13	14	15	14	
10			24	24	22	20	12	12	13	14	14	15	

	MASSACHUSETTS BAY TRANSPORTATION AUTHORITY	RAILROAD OPERATIONS	DWG. NO. 2504
			Oct. 28, 1992 <small>ISSUE DATE</small>
REPLACEMENT BOLTS FOR SELF-GUARDED FROGS			
<small>ENGINEERING OFFICER</small>			
<small>ENGINEERING OFFICER</small>		<small>CHIEF ENGINEERING OFFICER</small>	

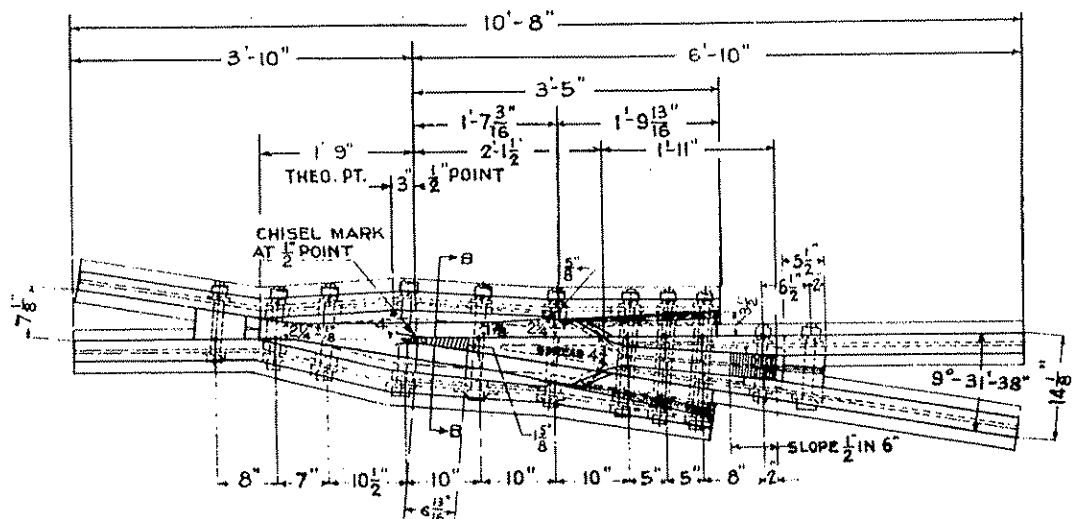

NOTE 1: - ACTUAL FROG POINT TO BE $\frac{3}{16}$ " BELOW WING LEVEL; SLOPING TO ZERO AT $\frac{1}{8}$ " WIDTH OF POINT (TOP SLOPE $\frac{3}{16}$ " IN $\frac{6}{16}$ "

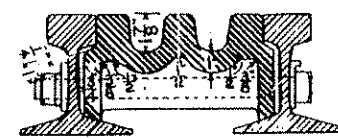
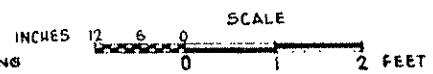

SECTION B-B FOR 85 LB. RAILS

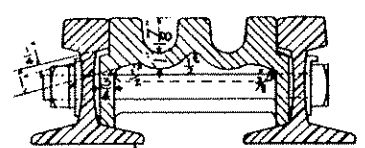

SECTION B-B FOR 100 LB AND HEAVIER RAILS.

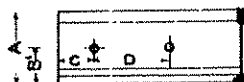

WEIGHT	RAIL DRILLING FOR JOINTS				DIAM. OF HOLE	BOLTS DIAM. OVER THREADS	
	A	B	C	D		JOINT	FROG
85#	5 1/8	2 3/4	2 1/8	6	1 3/8	1 1/8	1 1/8
100#	6	2 3/4	2 1/8	7	1 3/8	1 1/8	1 1/8
112#	6 3/8	2 7/8	2 1/8	6 1/2	1 1/4	1 1/8	1 1/8
130#	6 3/4	3 1/8	2 1/8	5 1/2	1 1/4	1 1/8	1 1/8
131#	7 1/8	3 3/8	2 1/8	6 1/2	1 1/4	1 1/8	1 1/8
115#	6 5/8	2 7/8	3 1/2	6	1 1/4	1 1/8	1 1/8

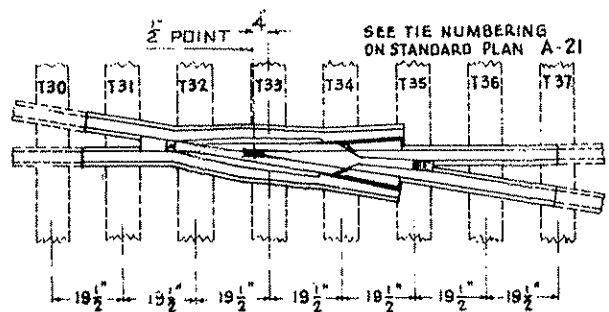

TIE SPACING

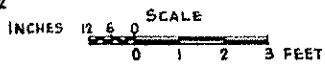

NOTES:-

DESIGN, DETAILS AND CONSTRUCTION SHALL CONFORM TO THE PLANS ADOPTED BY THE AMERICAN RAILWAY ENGINEERING ASSOCIATION AS RECOMMENDED PRACTICE.
 REFERENCES TO A. R. E. A. TRACKWORK PLANS:-
 *600 - DATA AND SECTIONS. *600-B. FROG POINT AND FLANGEWAYS.
 *601-3. GENERAL PLAN. NOTE-NO. 3.
 FROG BOLTS - A. R. E. A. SPECIFICATIONS 1936. FOR HIGH TENSILE STRENGTH, QUENCHED CARBON BOLTS WITH SQUARE HEADS, EXTRA HEAVY SQUARE NUTS, NUT LOCKS, ROLLED STEEL ANGLE WASHERS AND HEAD LOCKS; HANG HOLES $\frac{1}{4}$ " LARGER THAN FROG BOLT DIA.
 PLATES - THICKNESS 1". FURNISHED ONLY WHEN SPECIFIED. FOOT GUARDS FURNISHED BY R.R.
 WORKMANSHIP AND MATERIALS - A. R. E. A. SPECIFICATIONS FOR GENERAL TRACKWORK.
 NOTES:- ON FROG CASTING FOR 100-112-115-130-131 RAILS.
 BOLT SHROUDS TO BE ELIMINATED. CROSS RIBS BETWEEN THE SIDE WALLS TO BE S-SHAPED. CROSS RIBS TO BE ATTACHED TO SIDE WALLS ONLY, AND TO BE PLACED APPROXIMATELY EVERY SECOND BOLT SPACING AND OCCUR BETWEEN BOLT HOLES.
 I BEAM DESIGN TO BE USED IN HEEL EXTENSION.

T	MASSACHUSETTS BAY TRANSPORTATION AUTHORITY	RAILROAD OPERATIONS	DWG. NO. 2506
			Nov. 17, 1986 ISSUE DATE

**B & M NO. 6 RAILBOUND
MANGANESE STEEL FROG**

ENGINEERING OFFICER CHIEF ENGINEERING OFFICER

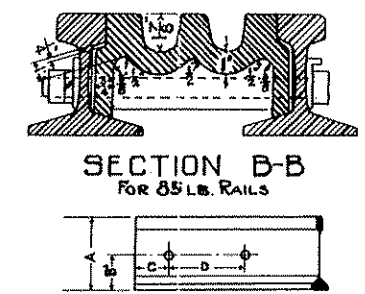
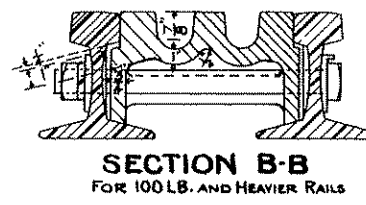
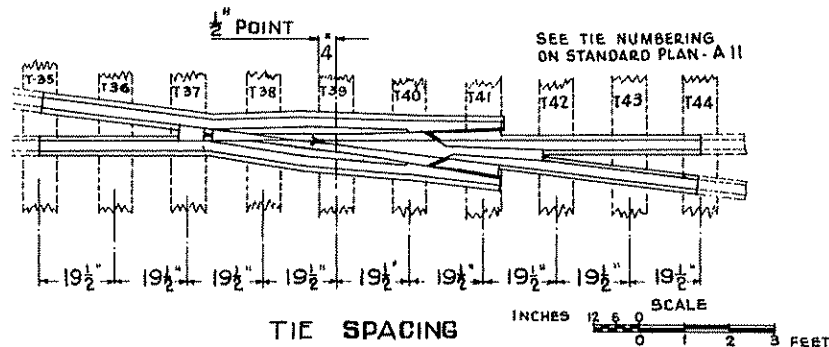
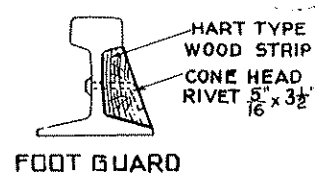
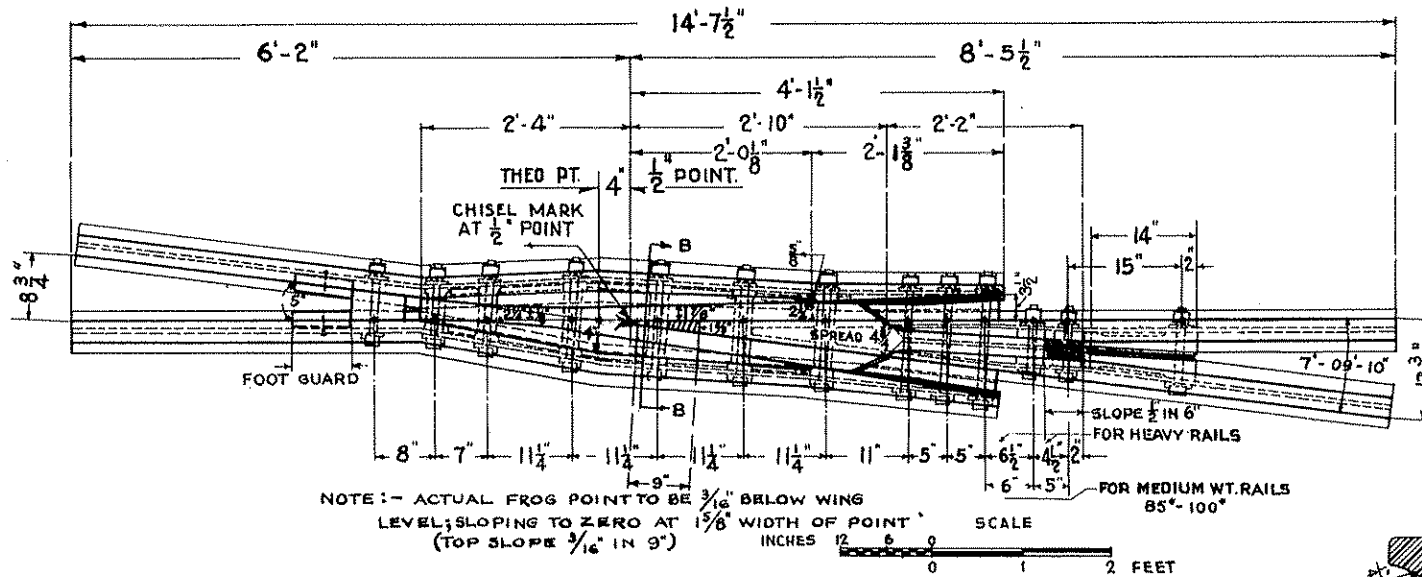

WEIGHT	RAIL DRILLING FOR JOINTS				DIAM. BOLTS		
	A	B	C	D	OF JOINT HOLE	DIAM. OVER THREADS	THROUGHS
85*	5 3/8"	2 1/4"	2 1/8"	6"	1 3/32"	1 1/8"	1 1/8"
100*	6"	2 3/4"	2 1/8"	7"	1 3/32"	1 1/8"	1 1/8"
112*	6 5/8"	2 7/8"	2 1/2"	6 1/2"	1 1/4"	1 1/8"	1 3/8"
130*	6 3/4"	3 1/8"	2 3/32"	5 1/2"	1 1/4"	1 1/8"	1 3/8"
131*	7 1/8"	3 3/32"	2 1/2"	6 1/2"	1 1/4"	1 1/8"	1 3/8"
115**	6 5/8"	2 7/8"	3 1/2"	6"	1 1/4"	1 1/8"	1 3/8"

NOTES:-
 DESIGN, DETAILS AND CONSTRUCTION SHALL CONFORM TO THE PLANS ADOPTED BY THE AMERICAN RAILWAY ENGINEERING ASSOCIATION AS RECOMMENDED PRACTICE. REFERENCES TO A.R.E.A. TRACKWORK PLANS.-
 *800 - DATA AND SECTIONS. #600-B - FROG POINT AND FLANGEWAYS. #601-3 GENERAL PLAN, NOTE NO. 3
 FROG BOLTS - A.R.E.A. SPECIFICATIONS 1936 FOR HIGH TENSILE STRENGTH, QUENCHED CARBON BOLTS WITH SQUARE HEADS, EXTRA HEAVY SQUARE NUTS, NUT LOCKS, ROLLED STEEL ANGLE WASHERS AND HEAD LOCKS. MANG. HOLES 1/8" LARGER THAN FROG BOLT DIA. PLATES - THICKNESS 1". FURNISHED ONLY WHEN SPECIFIED. FOOT GUARDS FURNISHED BY R.R. WORKMANSHIP AND MATERIALS - A.R.E.A. SPECIFICATIONS FOR GENERAL TRACKWORK.
 NOTES:- ON FROG CASTING FOR 100-112-115-130-131 RAILS.
 BOLT SHROUDS TO BE ELIMINATED. CROSS RIBS BETWEEN THE SIDE WALLS TO BE S-SHAPED. CROSS RIBS TO BE ATTACHED TO SIDE WALLS ONLY, AND TO BE PLACED APPROXIMATELY EVERY SECOND BOLT SPACING AND OCCUR BETWEEN BOLT HOLES. T BEAM DESIGN TO BE USED IN HEEL EXTENSION.

MASSACHUSETTS BAY TRANSPORTATION AUTHORITY	RAILROAD OPERATIONS	DWG. NO. 2508	ISSUE NO.
		Nov. 17, 1986	
B & M NO. 8 RAILBOUND MANGANESE STEEL FROG			
ENGINEERING OFFICER		CHIEF ENGINEERING OFFICER	

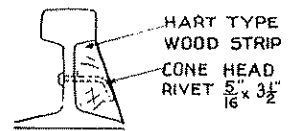
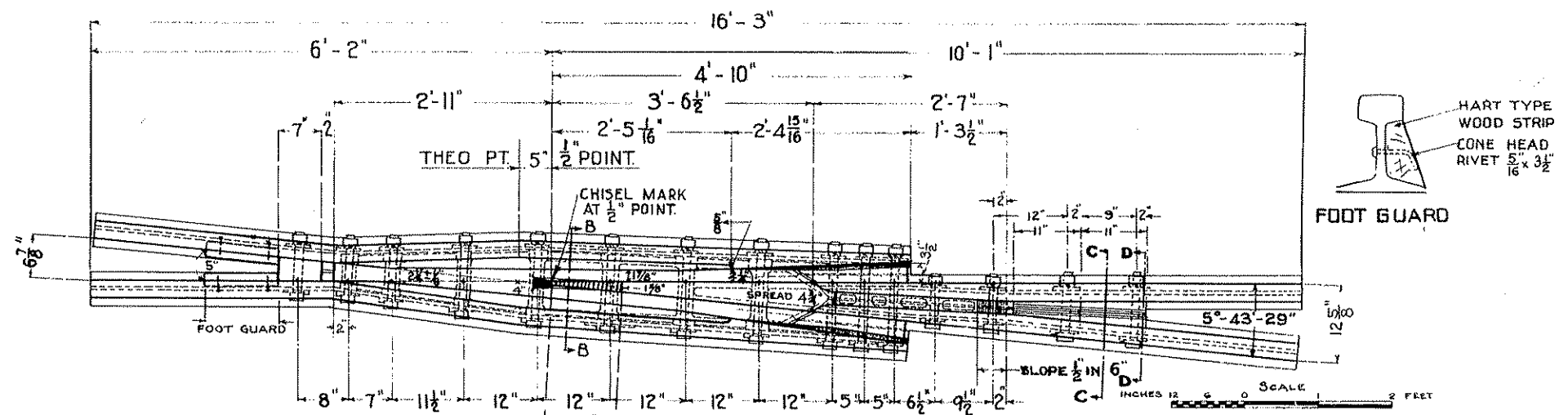

NOTE:- ACTUAL FROG POINT TO BE $\frac{3}{16}$ " BELOW WING LEVEL; SLOPING TO ZERO AT $\frac{1}{8}$ " WIDTH OF POINT (TOP SLOPE $\frac{3}{16}$ " IN $1\frac{1}{4}$ ")

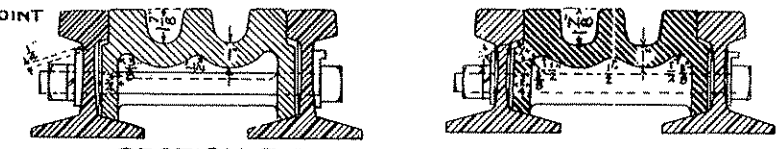

SECTION B-B FOR 100 LB. AND HEAVIER RAILS
SECTION B-B FOR 85 LB. RAIL ONLY

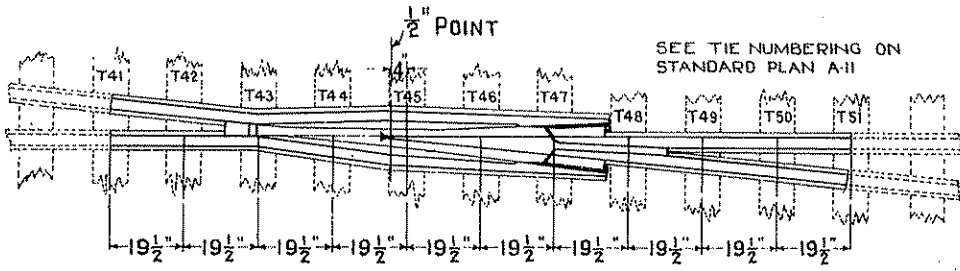

TIE SPACING

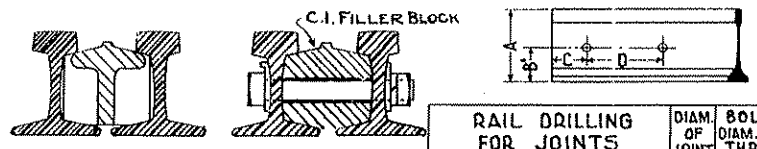

SECTION C-C FOR 100 LB. & HEAVIER RAILS
SECTION D-D

WEIGHT	RAIL DRILLING FOR JOINTS				DIAM. OF HOLE	BOLTS OF JOINT	DIAM. OVER THREADS	FROG
	A	B	C	D				
85*	5 3/8	2 7/8	2 1/2	6	1 7/32	1 1/8	1 1/8	
100*	6	2 7/8	2 1/8	7	1 7/32	1 1/8	1 1/8	
112*	6 5/8	2 7/8	2 1/2	6 1/2	1 1/4	1 1/8	1 3/8	
130*	6 3/4	3 1/16	2 1/2	5 1/2	1 1/4	1 1/8	1 3/8	
131*	7 1/8	3 3/32	2 1/2	6 1/2	1 1/4	1 1/8	1 3/8	
115*	6 5/8	2 7/8	3 1/2	6	1 1/4	1 1/8	1 3/8	

NOTES:-
 DESIGN, DETAILS AND CONSTRUCTION SHALL CONFORM TO THE PLANS ADOPTED BY THE AMERICAN RAILWAY ENGINEERING ASSOCIATION AS RECOMMENDED PRACTICE.
 REFERENCES TO A.R.E.A. TRACKWORK PLANS.-
 * 600 - DATA AND SECTIONS. * 600-B- FROG POINT & FLANGEWAYS.
 * 604-5- GENERAL PLAN. NOTE NO.3.
 FROG BOLTS-A.R.E.A. SPECIFICATIONS 1936 FOR HIGH TENSILE STRENGTH, QUENCHED CARBON BOLTS WITH SQUARE HEADS, EXTRA HEAVY SQUARE NUTS, NUT LOCKS, ROLLED STEEL ANGLE WASHERS AND HEAD LOCKS. MANG. HOLES 1/4" LARGER THAN FROG BOLT DIA.
 PLATES - THICKNESS 1". FURNISHED ONLY WHEN SPECIFIED. FOOT GUARDS FURNISHED BY R.R.
 WORKMANSHIP AND MATERIALS - A.R.E.A. SPECIFICATIONS FOR GENERAL TRACKWORK.
 NOTES - ON FROG CASTING FOR 100* 112* 115* 130* 131* RAILS.
 BOLT SHROUDS TO BE ELIMINATED. CROSS RIBS BETWEEN THE SIDE WALLS TO BE S-SHAPED. CROSS RIBS TO BE ATTACHED TO SIDE WALLS ONLY AND TO BE PLACED APPROXIMATELY EVERY SECOND BOLT SPACING AND OCCUR BETWEEN BOLT HOLES.
 I BEAM DESIGN TO BE USED IN HEEL EXTENSION.

T	MASSACHUSETTS BAY TRANSPORTATION AUTHORITY	RAILROAD OPERATIONS	DWG. NO. 2510
			Nov. 17, 1986
			ISSUE DATE ISSUE NO.

**B & M NO. 10 RAILBOUND
MANGANESE STEEL FROG**

ENGINEERING OFFICER CHIEF ENGINEERING OFFICER

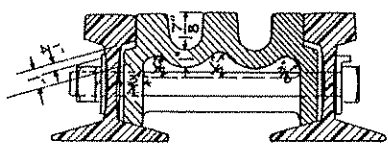
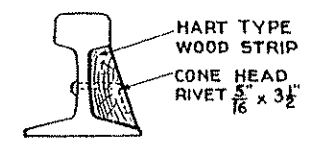
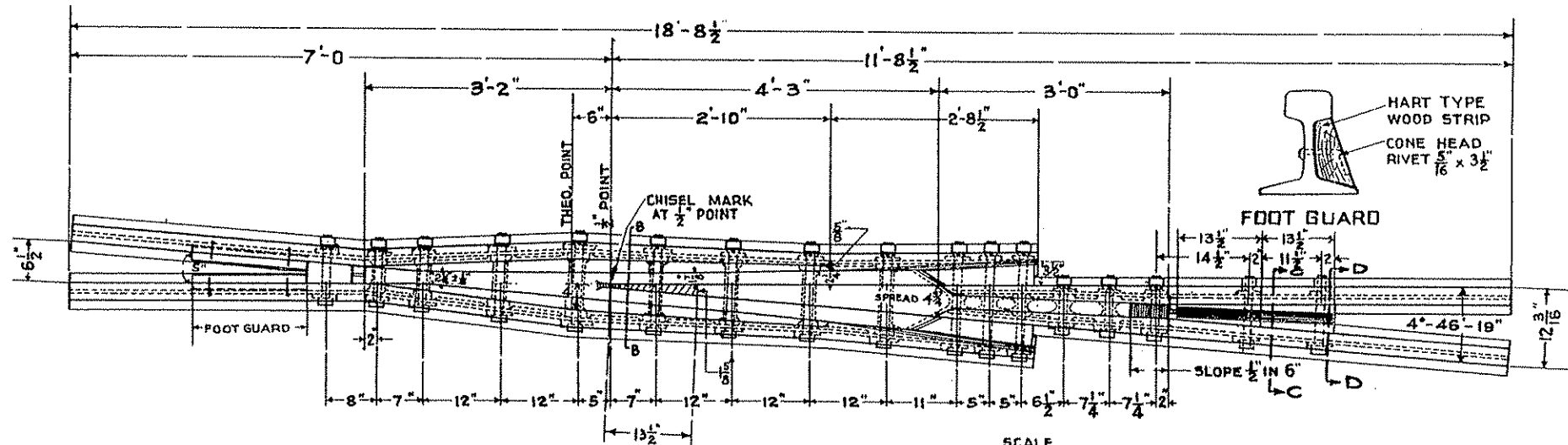

SECTION B-B
For 100LB AND HEAVIER RAILS

NOTE :- ACTUAL FROG POINT TO BE $\frac{3}{16}$ " BELOW WING LEVEL; SLOPING TO ZERO AT $\frac{1}{8}$ " WIDTH OF POINT (TOP SLOPE $\frac{3}{16}$ " IN $1\frac{1}{2}$ ")

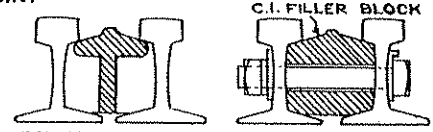
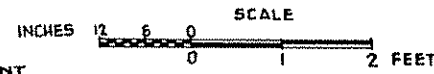

SECTION C-C
For 100LB AND HEAVIER RAILS

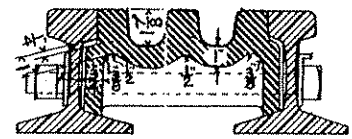

SECTION B-B
For 35 LB RAIL

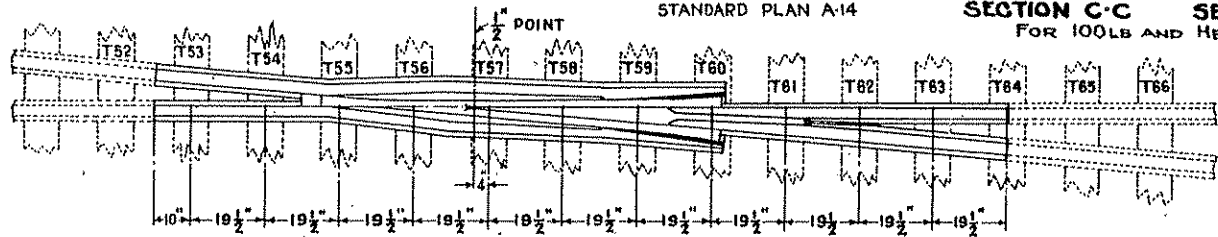

TIE SPACING

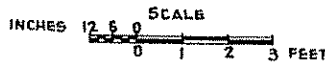

WEIGHT	RAIL DRILLING FOR JOINTS				DIAM OF JOINT HOLE	BOLTS DIAM. OVER THREADS	
	A	B	C	D		JOINT	FROG
85*	5/16	2/8	2 15/16	6"	1 3/32	1 1/8	1 1/8
100*	6"	2 3/4	2 7/16	7"	1 3/32	1 1/8	1 1/4
112*	6 7/8	2 7/8	2 1/2	6 1/2"	1 1/4	1 1/8	1 3/8
130*	8 1/4	3 3/8	2 1/2	5 1/2"	1 1/4	1 1/8	1 3/8
131*	7 1/8	3 3/32	2 1/2	6 1/2"	1 1/4	1 1/8	1 3/8
116*	6"	2 1/8	3 1/2	6"	1 1/4	1 1/8	1 3/8

NOTES:-

DESIGN, DETAILS AND CONSTRUCTION SHALL CONFORM TO THE PLANS ADOPTED BY THE AMERICAN RAILWAY ENGINEERING ASSOCIATION AS RECOMMENDED PRACTICE. REFERENCES TO A-R-E-A TRACKWORK PLANS:-
 #600 - DATA AND SECTIONS. #600-B - FROG POINT AND FLANGEWAYS.
 #609 - GENERAL PLAN, NOTE NO. 3.
 FROG BOLTS - A.R.E.A. SPECIFICATIONS 1936 FOR HIGH TENSILE STRENGTH, QUENCHED CARBON BOLTS WITH SQUARE HEADS, EXTRA HEAVY SQUARE NUTS, NUT LOCKS, ROLLED STEEL ANGLE WASHERS AND HEAD LOCKS. MANG. HOLES $\frac{1}{4}$ " LARGER THAN FROG BOLT DIA. PLATES - THICKNESS 1". FURNISHED ONLY WHEN SPECIFIED. FOOT GUARDS FURNISHED BY R.R. WORKMANSHIP AND MATERIALS A-R-E-A SPECIFICATIONS FOR GENERAL TRACKWORK.
 NOTES ON FROG CASTING FOR 100* 112* 115* 130* 131* RAILS.
 BOLT THROUGHS TO BE ELIMINATED. CROSS RIBS BETWEEN THE SIDE WALLS TO BE S-SHAPED. CROSS RIBS TO BE ATTACHED TO SIDE WALLS ONLY, AND TO BE PLACED APPROXIMATELY EVERY SECOND BOLT SPACING AND OCCUR BETWEEN BOLT HOLES.

T	MASSACHUSETTS BAY TRANSPORTATION AUTHORITY	RAILROAD OPERATIONS	DWG. NO. 2512
			Nov. 17, 1966
			ISSUE DATE

B & M NO. 12 RAILBOUND MANGANESE STEEL FROG

ENGINEERING OFFICER CHIEF ENGINEERING OFFICER

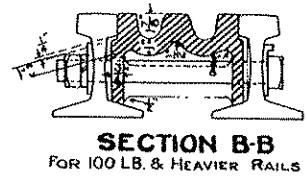
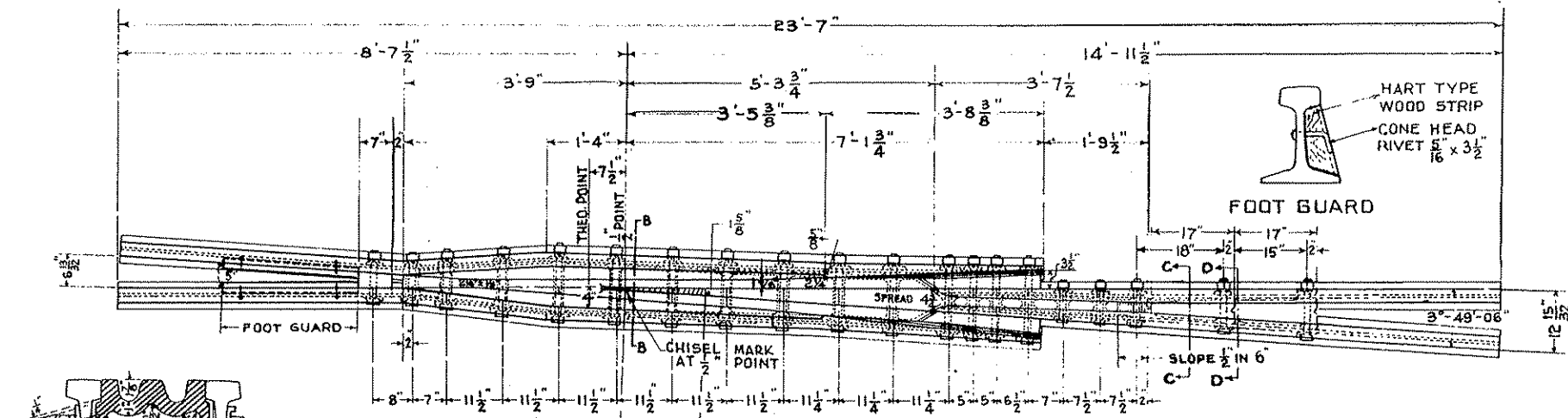

NOTE: - ACTUAL FROG POINT TO BE $\frac{3}{16}$ " BELOW WING LEVEL; SLOPING TO ZERO AT $\frac{1}{8}$ " WIDTH OF POINT (TOP SLOPE $\frac{3}{16}$ " IN $\frac{16}{8}$ ")

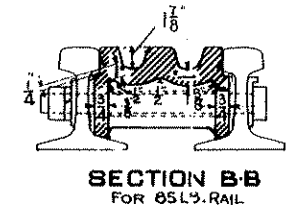
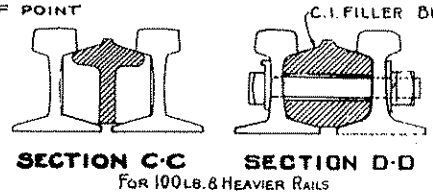

SEE TIE NUMBERING ON STANDARD PLAN A-15

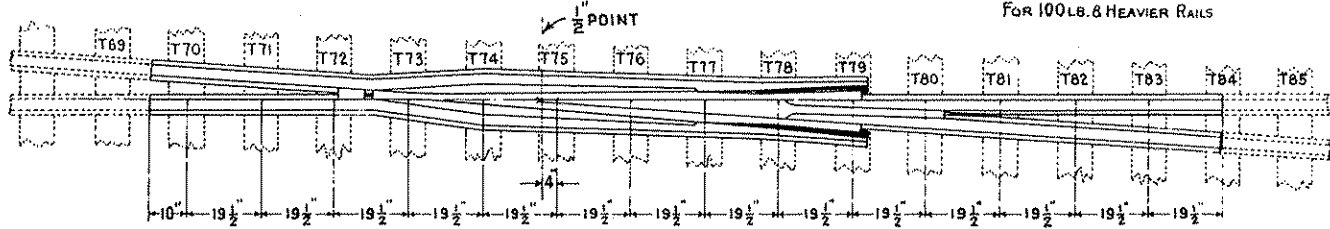

TIE SPACING INCHES 12 6 0 SCALE 0 1 2 3 FEET

WEIGHT	RAIL DRILLING FOR JOINTS				HOLE	DIAM. OF JOINT	BOLTS DIAM. OVER THREADS
	A	B	C	D			
85*	5/16	2 1/64	2 1/16	5	1 7/32	1 1/8	1 1/8
100*	6	2 3/64	2 7/16	7	1 7/32	1 1/8	1 1/4
112**	6 5/8	2 7/8	2 1/2	5 1/2	1 1/4	1 1/8	1 3/8
130*	6 3/4	3 1/16	2 1/2	5 1/2	1 1/4	1 1/8	1 3/8
131*	7 1/8	3 3/32	2 1/2	5 1/2	1 1/4	1 1/8	1 3/8
115**	6 3/8	2 7/8	3 1/2	6	1 1/4	1 1/8	1 3/8

NOTES: - MEASUREMENTS AS SHOWN.
 DESIGN, DETAILS AND CONSTRUCTION SHALL CONFORM TO THE PLANS ADOPTED BY THE AMERICAN RAILWAY ENGINEERING ASSOCIATION AS RECOMMENDED PRACTICE.
 REFERENCES TO A.R.E.A. TRACKWORK PLANS: -
 *600 - DATA AND SECTIONS. *600-B - FROG POINT AND FLANGWAYS.
 *610 - GENERAL PLANS, NOTE-NO. 3.
 FROG BOLTS - A R E A SPECIFICATIONS 1936 FOR HIGH TENSILE STRENGTH, QUENCHED CARBON BOLTS WITH SQUARE HEADS, EXTRA HEAVY SQUARE NUTS, NUT LOCKS, ROLLED STEEL ANGLE WASHERS AND HEAD LOCKS. MANG. HOLES 1/4" LARGER THAN FROG BOLT DIA. PLATES - THICKNESS 1". FURNISHED ONLY WHEN SPECIFIED. FOOT GUARDS FURNISHED BY R.R.
 WORKMANSHIP AND MATERIALS - A.R.E.A. SPECIFICATIONS FOR GENERAL TRACKWORK.
 NOTES - ON FROG CASTING FOR 100*-112*-115*-130*-131* RAILS.
 BOLT SHROUDS TO BE ELIMINATED. CROSS RIBS BETWEEN THE SIDE WALLS TO BE S-SHAPED. CROSS RIBS TO BE ATTACHED TO SIDE WALLS ONLY AND TO BE PLACED APPROXIMATELY EVERY SECOND BOLT SPACING AND OCCUR BETWEEN BOLT HOLES.
 I BEAM DESIGN TO BE USED IN HEEL EXTENSION

MASSACHUSETTS BAY TRANSPORTATION AUTHORITY	RAILROAD OPERATIONS	DWG. NO. 2515	
		Nov. 17, 1986	
B & M NO. 15 RAILBOUND MANGANESE STEEL FROG			
 ENGINEERING OFFICER		 CHIEF ENGINEERING OFFICER	

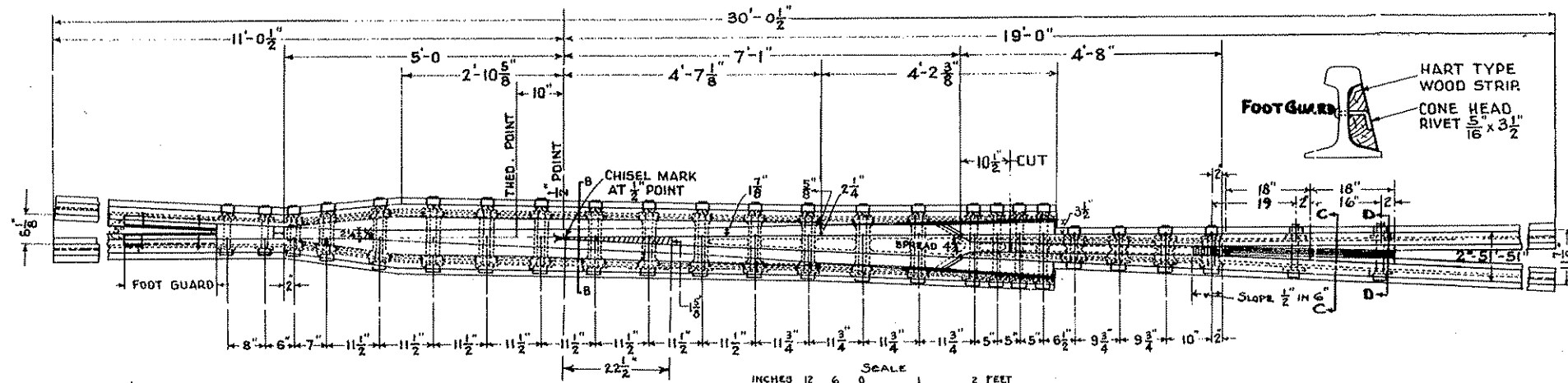

NOTE 1 - ACTUAL FROG POINT TO BE $\frac{3}{16}$ " BELOW WING LEVEL; SLOPING TO ZERO AT $\frac{1}{8}$ " WIDTH OF POINT (TOP SLOPE $\frac{1}{16}$ " IN $2\frac{1}{2}$ ")

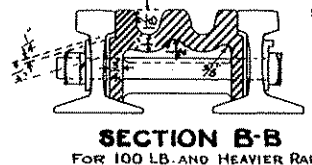

SECTION B-B
FOR 100 LB. AND HEAVIER RAILS

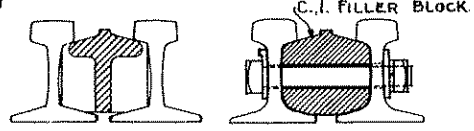

SECTION C-C
FOR 100 LB. AND HEAVIER RAILS

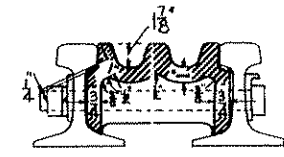

SECTION B-B
FOR 85 LB. RAIL

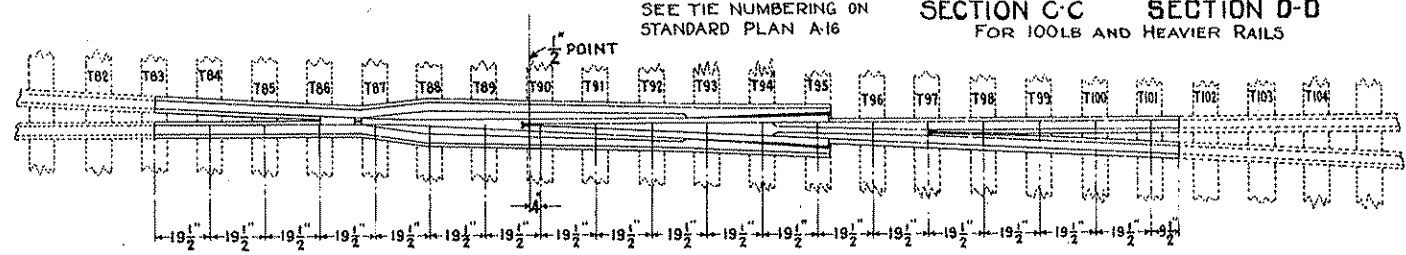

TIE SPACING

INCHES 12 6 0 SCALE 0 1 2 3 4 FEET

WEIGHT	RAIL DRILLING FOR JOINTS				DIAM. OF HOLE	BOLTS	
	A	B	C	D		DIAM. OVER THREADS	JOINT FROG
85#	5 3/16	2 1/8	2 1/8	6"	1 3/32	1 1/16	1 1/8
100#	6"	2 3/8	2 3/8	7"	1 1/32	1 1/16	1 1/4
112#	6 7/8	2 7/8	2 7/8	6 1/2"	1 1/4	1 1/8	1 3/8
130#	6 3/4	3 1/16	2 13/32	5 1/2"	1 1/4	1 1/8	1 3/8
131#	7 1/8	3 3/32	2 7/8	6 1/2"	1 1/4	1 1/8	1 3/8
115#	6 5/8	2 7/8	3 1/2"	6"	1 1/4	1 1/8	1 3/8

NOTES

DESIGN, DETAILS, AND CONSTRUCTION SHALL CONFORM TO THE PLANS ADOPTED BY THE AMERICAN RAILWAY ENGINEERING ASSOCIATION AS RECOMMENDED PRACTICE. REFERENCES TO A.R.E.A. TRACKWORK PLANS -
 * 600 - DATA AND SECTIONS. * 600-B - FROG POINT AND FLANGEWAYS. * 606-7 - GENERAL PLAN, NOTE - NO. 3.
 FROG BOLTS - A.R.E.A. SPECIFICATIONS 1936 FOR HIGH TENSILE STRENGTH, QUENCHED CARBON BOLTS WITH SQUARE HEADS, EXTRA HEAVY SQUARE NUTS, NUT LOCKS, ROLLED STEEL ANGLE WASHERS AND HEAD LOCKS. MANG. HOLES $\frac{1}{4}$ " LARGER THAN FROG BOLT DIA. PLATES - THICKNESS 1". FURNISHED ONLY WHEN SPECIFIED. FOOT GUARDS FURNISHED BY R.R. WORKMANSHIP AND MATERIALS - A.R.E.A. SPECIFICATIONS FOR GENERAL TRACKWORK.
 NOTES - ON FROG CASTING FOR 100-112-115-130-131 RAILS.
 BOLT SHROUDS TO BE ELIMINATED. CROSS RIBS BETWEEN THE SIDE WALLS TO BE S-SHAPED. CROSS RIBS TO BE ATTACHED TO SIDE WALLS ONLY AND TO BE PLACED APPROXIMATELY EVERY SECOND BOLT SPACING AND OCCUR BETWEEN BOLT HOLES.

MASSACHUSETTS RAILROAD TRANSPORTATION AUTHORITY	RAILROAD OPERATIONS	DWG. NO. 2520 Nov. 17, 1986. 1 <small>ISSUE DATE ISSUE NO.</small>
	B & M NO. 20 RAILBOUND MANGANESE STEEL FROG <i>Daniel Brennan</i> <i>W. A. ...</i> <small>ENGINEERING OFFICER CHIEF ENGINEERING OFFICER</small>	

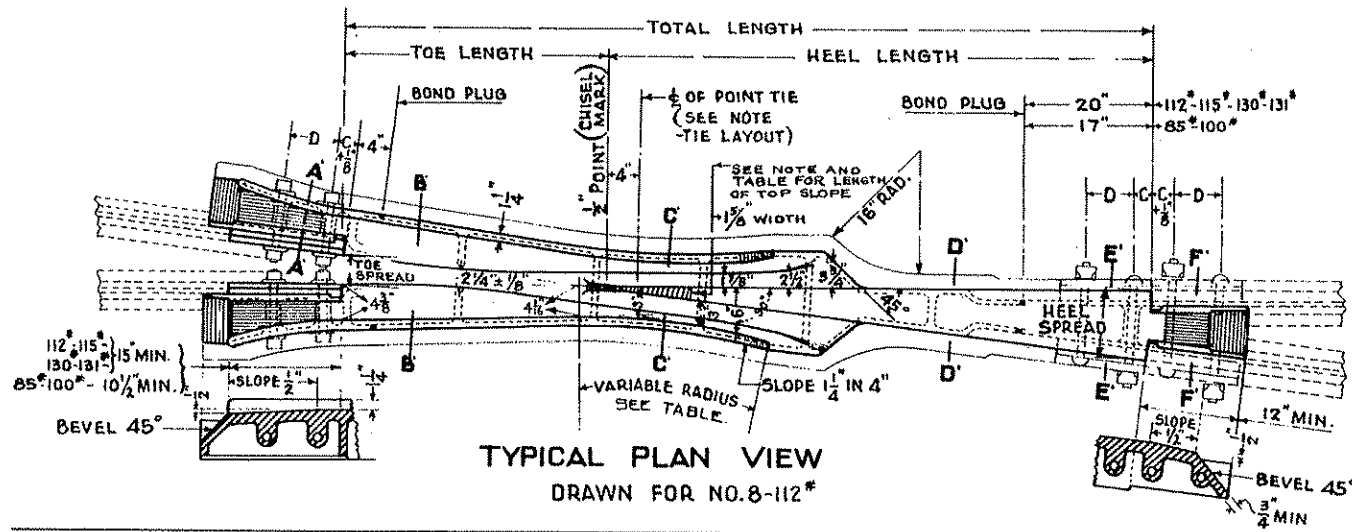

RAIL DRILLING FOR JOINTS					DIAM. OF HOLE	JOINT BOLT DIAM. OVER THROTS
WEIGHT	A	B	C	D		
85*	5 5/16	2 7/8	2 15/16	6"	1 1/2	1 1/16
100*	6"	2 7/8	2 7/8	7"	1 3/32	1 1/16
112*	6 3/8	2 7/8	2 7/8	6 1/2	1 1/4	1 1/8
130*	6 7/8	3 1/8	2 3/32	5 1/2	1 1/4	1 1/8
131*	7 1/8	3 5/16	2 1/2	6 1/2	1 1/4	1 1/8
115*	6 3/4	2 7/8	3 1/2	6"	1 1/4	1 1/8

FROG LENGTHS																			
FROG		85* RAIL					* 100* RAIL					112*, 115*, 130*, 131* RAILS							
NO.	ANGLE	TOTAL LGTH	TOE LGTH	TOP SPRD	HEEL LGTH	HEEL SPRD	VAR. RAD.	TOTAL LGTH	TOE LGTH	TOP SPRD	HEEL LGTH	HEEL SPRD	VAR. RAD.	TOTAL LGTH	TOE LGTH	TOP SPRD	HEEL LGTH	HEEL SPRD	VAR. RAD.
6	9°-31'-38"	5'-5"	20"	2 15/16	3'-9"	8"	4'-9"	5'-8"	21"	3"	3'-11"	8 1/16	4'-10"	7'-4"	2'-11"	5 1/16	4'-5"	9 1/8	5'-0"
7	9°-10'-18"	8'-3"	23"	2 3/32	4'-4"	7 1/16	6'-8"	6'-7"	2'-0"	2 1/16	4'-7"	8 3/8	6'-8"	8'-12"	2'-11"	4 1/2	5'-2"	9 3/32	7'-0"
8	7°-09'-10"	7'-3"	2'-3"	2 7/8	5'-0"	8"	8'-9"	7'-7"	2'-4"	3"	5'-3"	8 7/8	8'-10"	8'-11"	2'-11"	3 7/8	6'-0"	9 1/2	9'-2"
9	6°-21'-35"	8'-1"	2'-6"	2 13/16	5'-7"	7 1/16	11'-2"	8'-5"	2'-7"	2 1/16	5'-10"	8 1/4	11'-3"	9'-9"	2'-11"	3 7/8	6'-10"	9 3/32	11'-6"
10	5°-43'-29"	8'-11"	2'-9"	2 13/16	6'-2"	7 7/8	13'-11"	9'-4"	2'-10"	2 29/32	6'-8"	8 5/16	14'-0"	11'-4 1/2	3'-9"	4"	7'-7 1/2	9 5/8	14'-8"

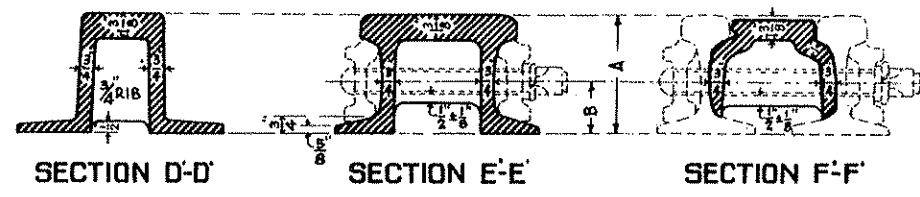
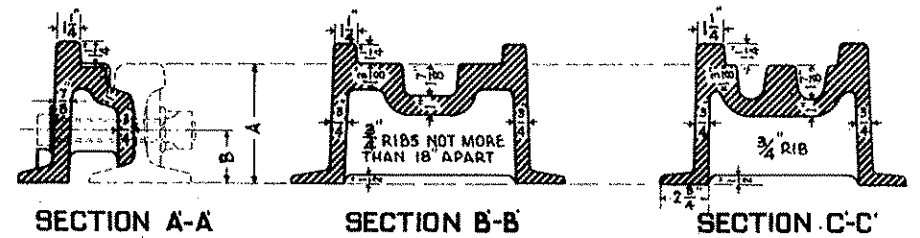

NOTES:

DESIGN, DETAILS AND CONSTRUCTION SHALL CONFORM TO THE PLANS ADOPTED BY THE AMERICAN RAILWAY ENGINEERING ASSOCIATION AS RECOMMENDED PRACTISE.

REFERENCES TO A.R.E.A. TRACKWORK PLANS:-
*640-DATA AND SECTIONS. *600 B-FROG POINT AND FLANGWAY.

BOLTS-FURNISHED WITH FROG. A.S.T.M. SPECIFICATION ASD FOR HIGH TENSION CARBON BOLTS, EXTRA HEAVY SQUARE NUTS, NUT LOCKS, ROLLED STEEL ANGLE WASHERS AND HEAD LOCKS.

BOLT HOLES-DIAMETER OF HOLES IN CASTINGS TO BE 1/8" LARGER THAN DIAMETER OF BOLTS. BOND PLUGS-INSERTS OF 3/4" SOFT STEEL IN VERTICAL WALLS. TO BE DRILLED WITH 5/8" HOLES AND PLUGGED TIGHTLY AT ONCE WITH LEAD RIVETS.

JOINT BARS-AT TOE TO BE FURNISHED WITH FROG. AT HEEL TO BE FURNISHED BY RAILROAD.

PLATES-FURNISHED ONLY WHEN SPECIALLY ORDERED.

MARKING-FROGS TO BE MARKED WITH NUMBER-WEIGHT OF RAIL AND MANUFACTURER'S NAME.

WORKMANSHIP AND MATERIAL-A.R.E.A. SPECIFICATIONS FOR GENERAL TRACKWORK.

TIE LAYOUTS FOR ALL SOLID MANG. SELF GUARDED FROGS- CENTER LINE OF POINT TIE IS 4" FROM THE 1/2" POINT-TOWARDS HEEL OF FROG. ALL OTHER TIES ARE SPACED 19 1/2" CENTER TO CENTER FROM THIS TIE.

NOTE 1:- ACTUAL FROG POINT TO BE 3/16" BELOW WING LEVEL; SLOPING TO ZERO AT 1 1/8" WIDTH OF POINT.

FROG NO.	TOP SLOPE LENGTH
6	6 15/16"
7	7 7/8"
8	9"
9	10 7/8"
10	11 1/4"

FOR 85, 10-100* FROGS - FURNISH RACOR INTEGRAL BASE SOLID MANGANESE STEEL SELF GUARDED FROG PER RAMAPO-AJAX PLAN (3206-H)

T	MASSACHUSETTS BAY TRANSPORTATION AUTHORITY	RAILROAD OPERATIONS	DWG. NO. 2530
			Nov. 17, 1986
		B & M SOLID MANGANESE STEEL SELF GUARDED FROGS	ISSUE NO. 1
<i>Daniel Brennan</i>		<i>W.A. Randall</i>	
ENGINEERING OFFICER		CHIEF ENGINEERING OFFICER	

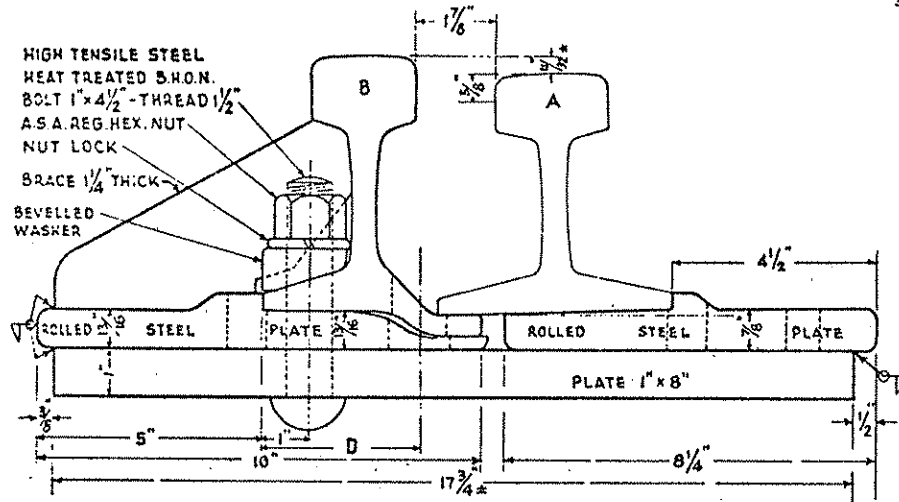
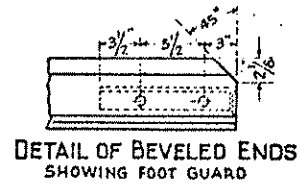

SECTION B-B THRU CENTER PLATE

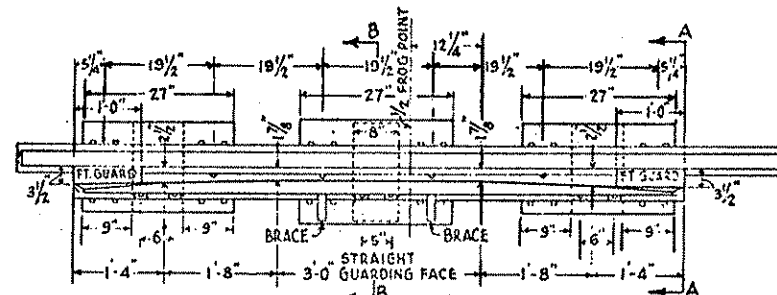

GUARD RAIL 9'-0" LONG FOR INSTALLING ON SIX TIES

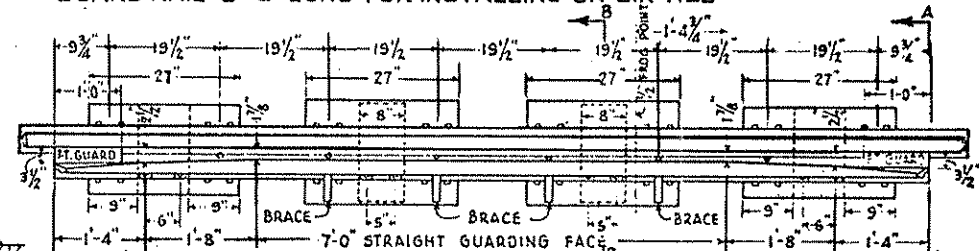

GUARD RAIL 13'-0" LONG FOR INSTALLING ON EIGHT TIES

PLACING OF HOOK FLANGE GUARD RAILS

NUMBER OF FROG	LENGTH OF GUARD RAIL	PLACE GUARD RAIL ON TIES NO.	PLACE PT. OF FROG ON TIE NO.	FOR TIE REFERENCE SEE STD. PLAN NO.
RIGID FROGS				
8	9 FT.	36 TO 41 INC.	39	F 8
9	" "	38 - 43 -	41	F 13
10	" "	42 - 47 -	45	F 9
12	13 "	52 - 59 -	57	F 12
15	" "	70 - 77 -	75	F 10
20	" "	85 - 92 -	90	F 11
SPRING RAIL FROGS				
8	9 FT.	36 TO 41 INC.	39	F 8
10	13 "	40 - 47 -	45	F 9
12	" "	52 - 59 -	57	F 12

RAIL		C	D	E
A	B			
85 ASCE	GT 96 R.E.	2 5/8"	3 3/8"	2 3/8"
100 N.H.	GT 96 R.E.	2 1/4"	4 1/16"	2 7/8"
112-115 R.E.	GT 104 R.E.	2 3/8"	3 1/8"	2 7/8"
130 R.E.	GT 104 R.E.	2 5/8"	3 1/16"	2 7/8"
131 R.E.	GT 120 R.E.	2 5/8"	3 7/8"	2 7/8"

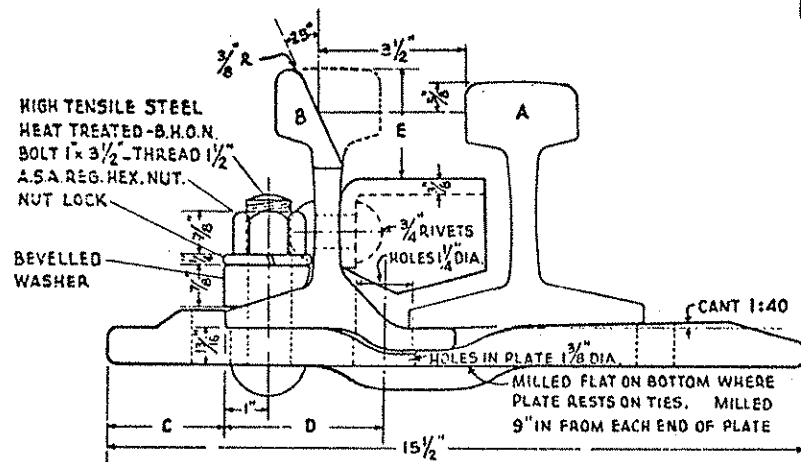

SECTION A-A AT END PLATE

T	MASSACHUSETTS BAY TRANSPORTATION AUTHORITY	RAILROAD	DWG. NO. 2540
		OPERATIONS	Nov. 17, 1986
		ISSUE DATE	ISSUE NO. 1
B & M HOOK FLANGE GUARD RAILS			
<i>David Brown</i> ENGINEERING OFFICER		<i>W. A. ...</i> CHIEF ENGINEERING OFFICER	

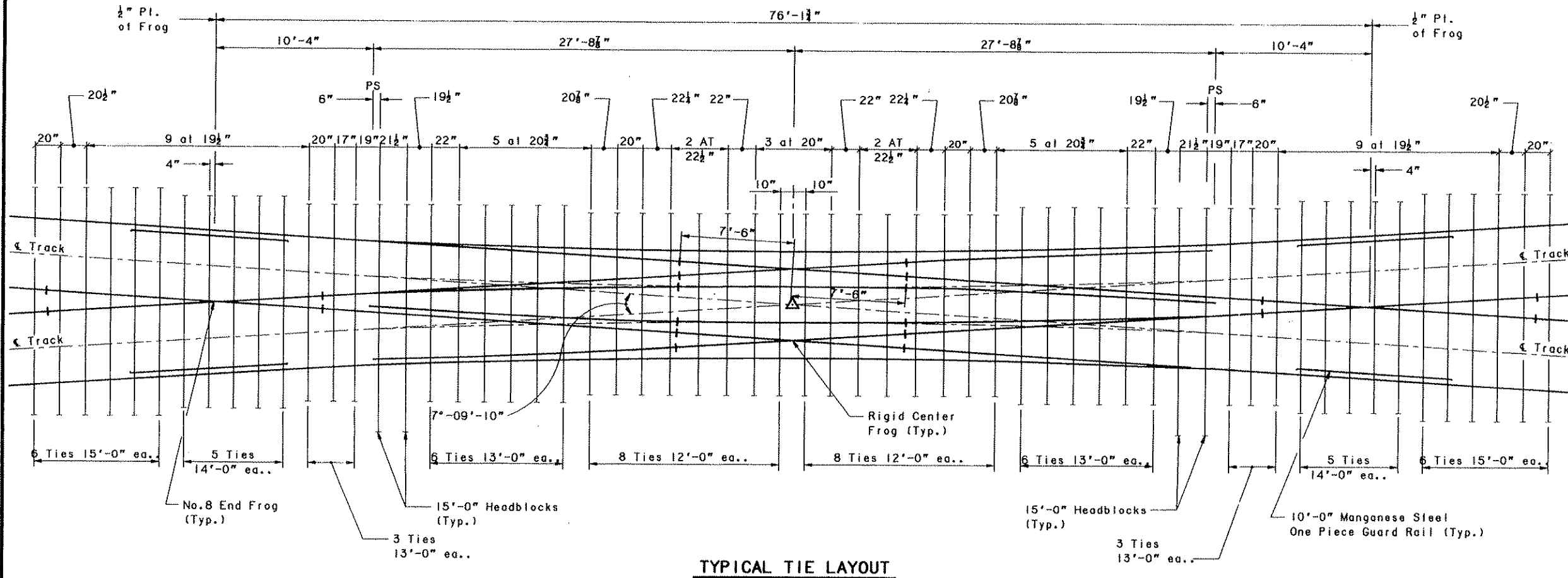

TYPICAL TIE LAYOUT

Notes:

1. Length of headblock timbers and orientation dependent on switch machine type and field location as affected by other adjacent special trackwork units.
2. Additional (or less) long timbers may be required depending on size and location of other adjacent special trackwork units.
3. No rail welds shall be made within limits of double slip switches. All connections shall be bolted except heel ends of end frogs may be welded.
4. Insulated joints shall be bolted "Poly" type joints.
5. Location and number of insulated joints and other rail joints to be determined on a site specific basis.

LONG TIMBERS REQUIRED

Quantity	Length
16	12'-0"
18	13'-0"
10	14'-0"
12	15'-0"
4	Headblocks
60	Total

Note 1
Note 2

MASSACHUSETTS BAY TRANSPORTATION AUTHORITY	RAILROAD OPERATIONS	DWG. NO. 2602	ISSUE NO.
		JAN. 5, 1996	

**NO. 8 DOUBLE SLIP/RIGID FROG
TIE LAYOUT**

John D. Pary
SECTION CHIEF

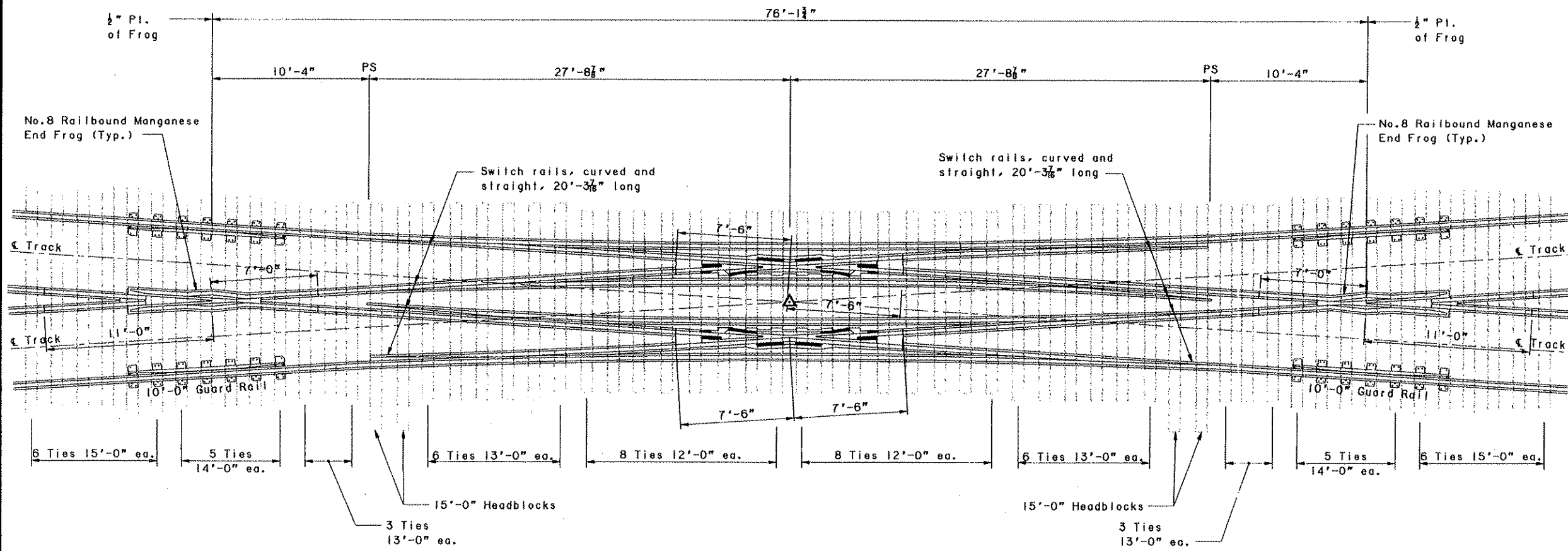

GENERAL LAYOUT

Notes:

1. 10'-0" Long One Piece Manganese Steel Guard Rails (4) per Standard Plan No. 2300.
2. No. 8 Railbound Manganese Steel End Frogs (2) per Standard Plan No. 2084.
3. No. 8, Rigid, Solid Manganese Center Frogs (2) per Standard Plan 2605.
4. Furnish not less than 2 Gage Plates spanning all rails at Center Frogs and 1 Gage Plate spanning all rails at both switch point locations.
5. Furnish 1:80 Cant Transition Tie Plates and Flat Plates as required on both ends of double slip.
6. Entire unit to be resiliently fastened except through guard rails.
7. All switch rods to be vertical.

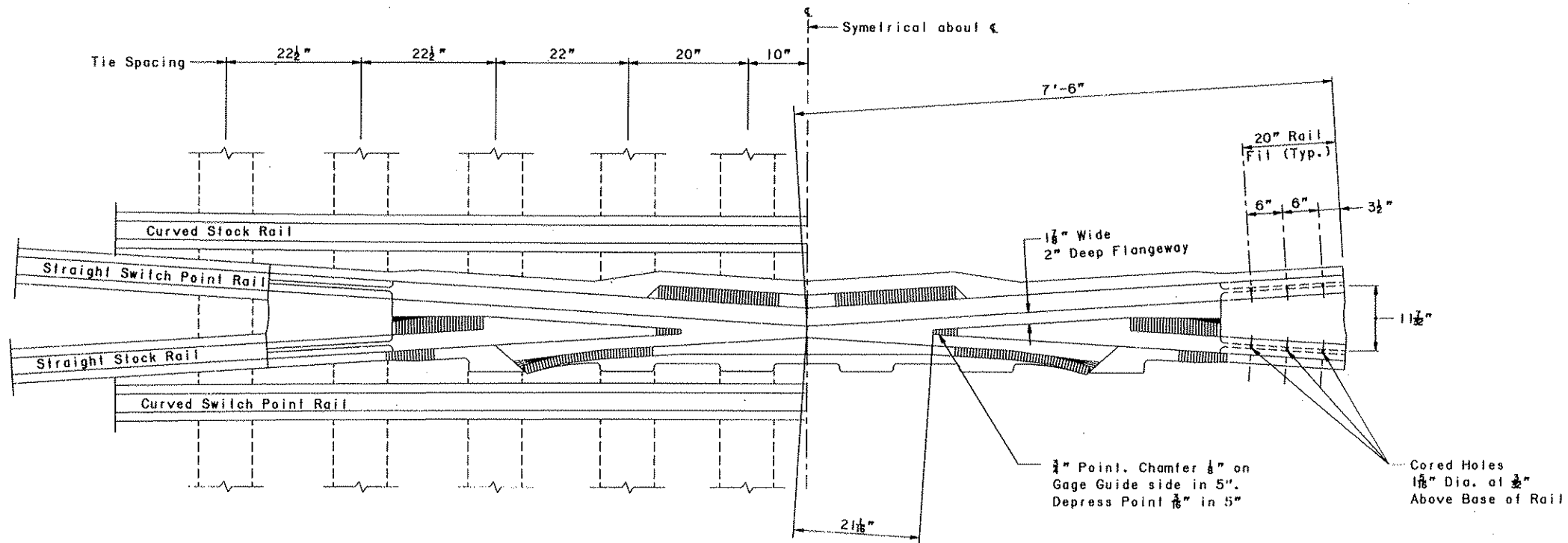

	MASSACHUSETTS BAY TRANSPORTATION AUTHORITY	RAILROAD OPERATIONS	DWG. NO. 2604
			JAN. 5, 1996 <small>ISSUE DATE</small>
NO. 8 DOUBLE SLIP/RIGID FROG GENERAL LAYOUT			 <small>SECTION CHIEF</small>



CENTER FROG

Notes:

1. Frog Angle is 7°-09'-10".
2. All Switch Point and Stock Rail Connections to Casting to be bolted, not welded.

 MASSACHUSETTS BAY TRANSPORTATION AUTHORITY	RAILROAD OPERATIONS	DWG. NO. 2605	 1
		Jan. 5, 1996 <small>ISSUE DATE</small>	

NO.8 DOUBLE SLIP/RIGID,
SOLID MANGENESE CENTER FROG

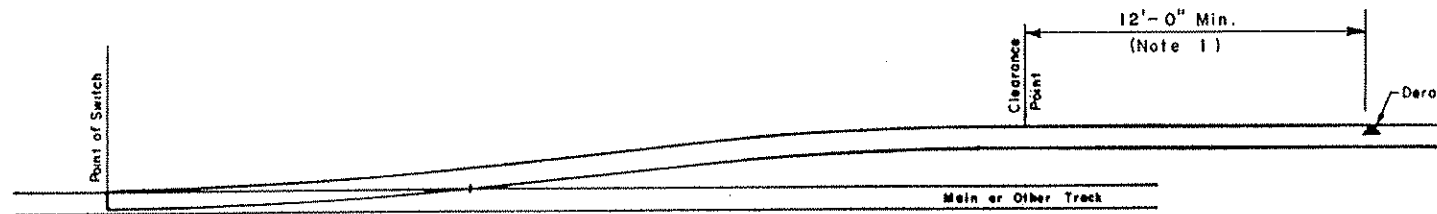

SECTION CHIEF

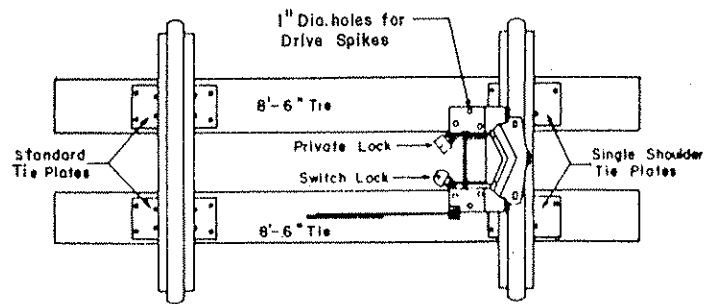

LOCATION OF DERAIL

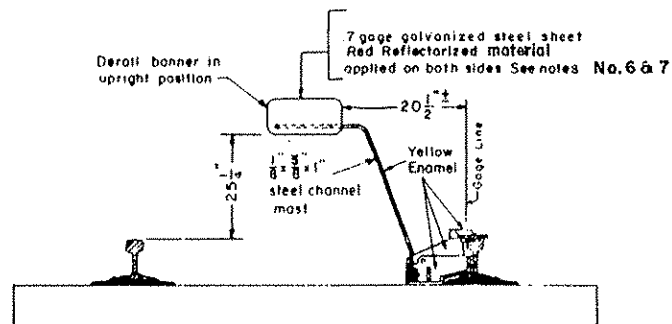

TOP VIEW



SIDE VIEW

DERAIL IN "NORMAL POSITION"

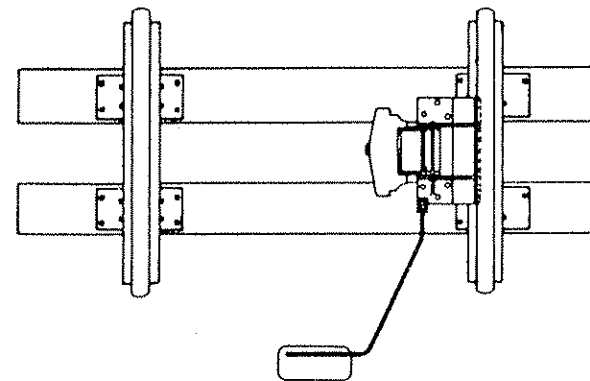

TOP VIEW

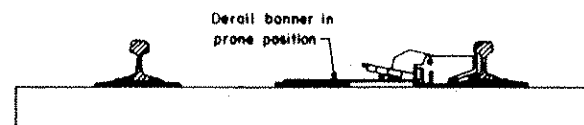

SIDE VIEW

DERAIL IN "REVERSE POSITION"

NOTE:

- Derail shall be placed a sufficient distance back from the clearance point to assure that derailed rolling equipment will not foul main or other track(s).
- Hinged block type derails to be used only on enginehouse ready and storage tracks.
- When ordering derail specify size:

Size	Weight of Rail
5	70 to 100 lb.
6	90 to 110 lb.
7	110 to 140 lb.
8	140 to 155 lb.
- Derail is to be painted yellow enamel over primer.
- All derails to accommodate padlocks on both ends, one a switch lock; the other a private lock.
- Reflectorized derail banners shall be used where high visibility is necessary and where not prohibited by public authorities having jurisdiction.
- Reflectorized sheeting material shall conform and be applied in accordance with current and applicable Mass. Highway Dept. Standards.
- Banners shall be fabricated from 7 gage galvanized steel sheet as one contiguous piece (No Joints or Seams Allowed).
- Shade of coloration shall be approved by the MBTA or their designated agent.
- Should reflectorized material be prohibited, a red, fade resistant paint shall be applied over a rust inhibitive primer on the banner.

NOTE: The derail shown is manufactured by Western-Cullen-Hayes

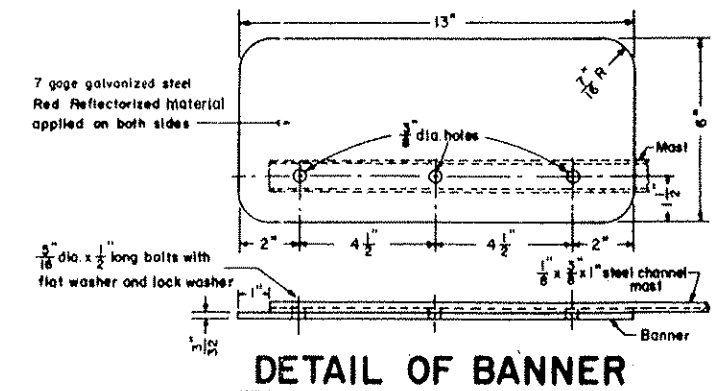

DETAIL OF BANNER

MASSACHUSETTS BAY TRANSPORTATION AUTHORITY	RAILROAD OPERATIONS	DWG. NO. 3000	ISSUE NO.
		Oct. 28, 1992	

HINGED BLOCK DERAIL

John D. Ray
ENGINEERING OFFICER

W. J. ...
CHIEF ENGINEERING OFFICER

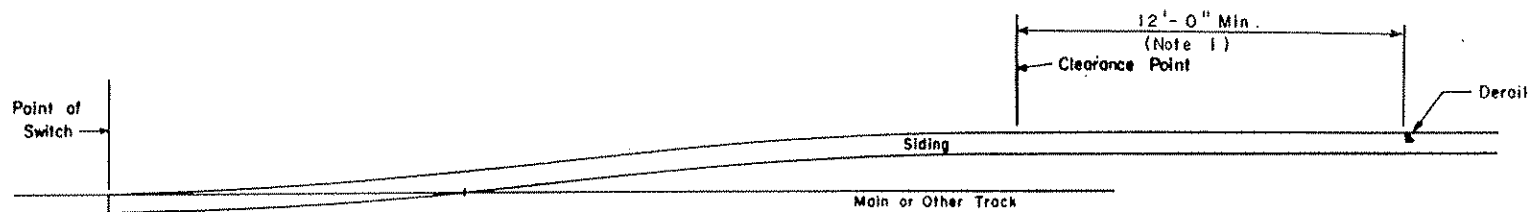

LOCATION OF DERAIL

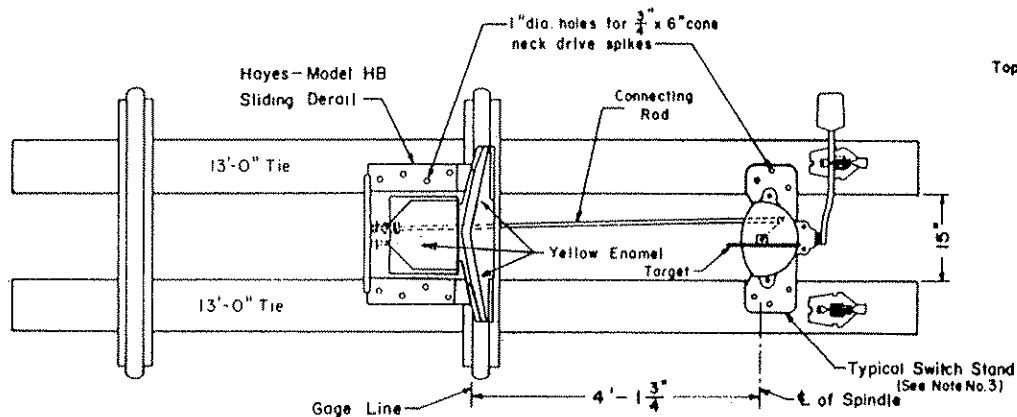

SWITCH STAND AND DERAIL INSTALLATION

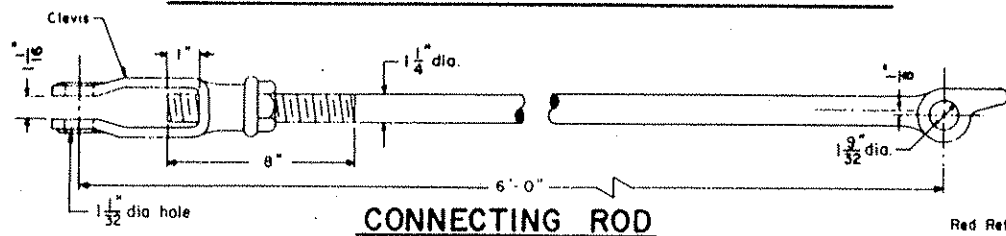

CONNECTING ROD FOR NEW CENTURY SWITCH STAND

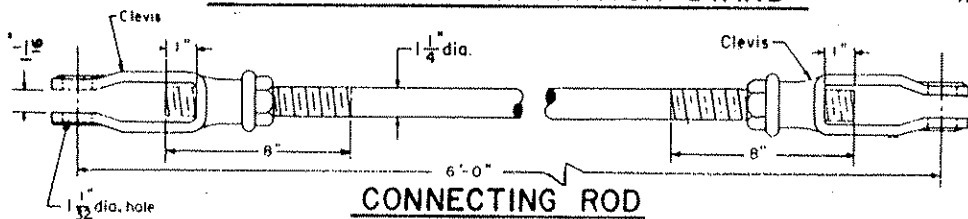

CONNECTING ROD FOR OTHER TYPES OF SWITCH STANDS

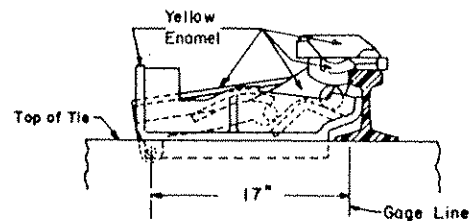

DERAIL IN "NORMAL POSITION"

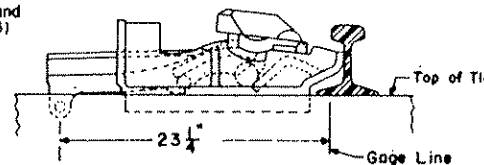

DERAIL IN "REVERSE POSITION"

Red ReflectORIZED Material applied on both sides

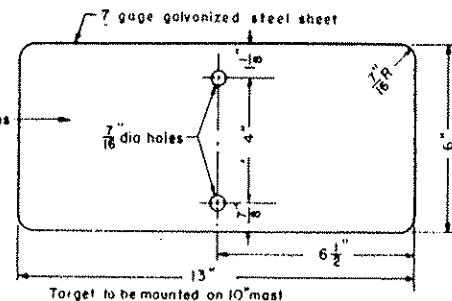

TARGET DETAILS

NOTES

- 1 - Derail shall be placed a sufficient distance back of the clearance point to make sure that derailed rolling equipment will not foul the main or other track.
 - 2 - The following switch stand is to be used to operate derail - New Century Switch Stand, Model 50-A as manufactured by Bethlehem Steel.
 - 3 - Others as approved by Chief Engineering Officer.
 - 3 - Switch stand to be in tension, with red target perpendicular to the rail, when the derail is in the normal position.
 - 4 - When ordering derail specify - Model and Size
 - Size 6 - for 90lb rail to 110lb rail
 - Size 7 - for 110lb rail to 140lb rail
 - Size 8 - for 140lb rail to 155lb rail
- Order derails with double ended derailing flanges which will operate as either left or right hand derails.

5 - All orders should state that derails will be operated by switch stands having a 4 3/4" throw

6 - All derails to accommodate padlocks on both ends, one a switch lock; the other a private lock.

7 - ReflectORIZED derail banners shall be used where high visibility is necessary and where not prohibited by public authorities having jurisdiction.

8 - ReflectORIZED sheeting material shall conform and be applied in accordance with current and applicable MHD Standards.

9 - Banners shall be fabricated from 7 gage galvanized steel sheet as one contiguous piece (No Joints or Seams Allowed).

10 - Shade of coloration shall be approved by the MBTA or their designated agent.

11 - Should reflectORIZED material be prohibited, a red, fade resistant paint shall be applied over a rust inhibitive primer on the banner.

12 - All items shown for maintenance of existing equipment, only.

13 - This type of derail shall NOT be installed in new installations without the written approval of the Chief Engineering Officer of the MBTA.

NOTE: The Derail Shown is Manufactured by Western-Cullen-Hayes.

T	MASSACHUSETTS BAY TRANSPORTATION AUTHORITY	RAILROAD OPERATIONS	DWG. NO. 3004
			Oct. 28, 1992 ISSUE DATE

SLIDING BLOCK DERAIL

ENGINEERING OFFICER CHIEF ENGINEERING OFFICER

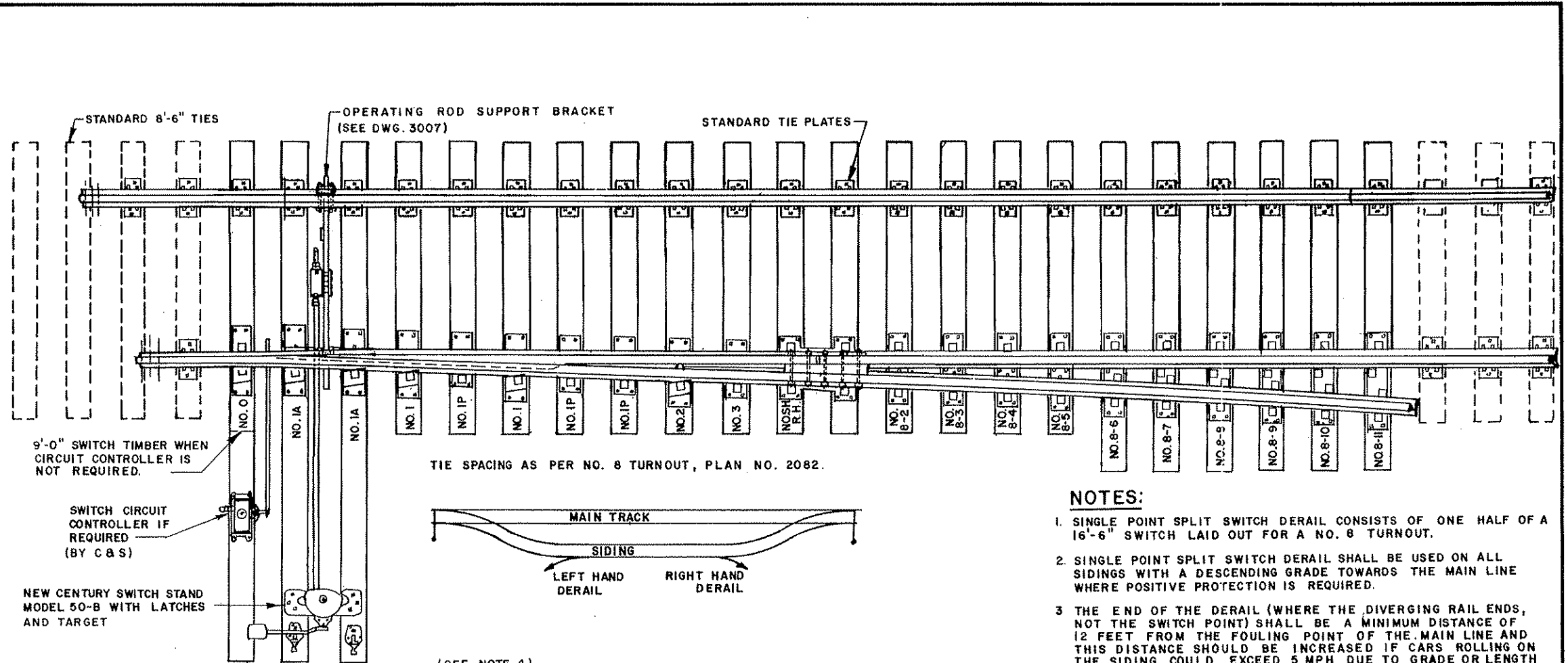

TIE SPACING AS PER NO. 8 TURNOUT, PLAN NO. 2082.

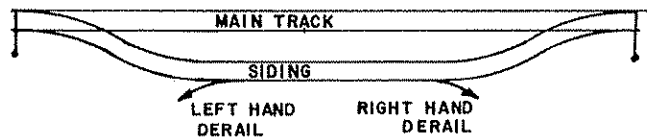

(SEE NOTE 4)

BILL OF MATERIAL

*SUPPLIED BY THE INSTALLER

QUAN.	DESCRIPTION	Reference Plan No.
1	16'-6" SWITCH POINT (R.H. or L.H.) COMPLETE WITH REINFORCING BARS, CLIP FOR NO. 1 ROD AND STOPS	2104
1	HEEL BLOCK ASSEMBLY, COMPLETE	2350
1	39'-0" UNDERCUT STOCK RAIL (R.H. or L.H.)	2104
1	NO. 0 ADJUSTABLE BRACE SLIDE PLATES	2106
2	NO. 1A " " " "	2106
2	NO. 1 " " " "	2106
1	NO. 2 " " " "	2106
3	NO. 1P SHOULDER SLIDE PLATES	2106
1	NO. 3 " " " "	2106
1	NO. SH HEEL PLATE (RH. or L.H.)	2106
1	SWITCH RAIL STOP	2350
1	ADJUSTABLE ROCKER CLIP FOR VERT. SWITCH RODS	2107
1	INSULATED VERTICAL SWITCH ROD (NO. 1 ONLY)	2107

QUAN.	DESCRIPTION	Reference Plan No.
10	TURNOUT PLATES FOR USE BEHIND HEEL (NO. 8-2to8-11)	2340
6	RESILIENTLY FASTENED ADJUSTABLE RAIL BRACES	2352
100	7" LOCK SPIKES	1216
13	5/8" x 6" AREA Spikes *	1210
44	RESILIENT FASTENER SPRING CLIPS -TYPE "E"	-
4	RESILIENT FASTENER SPRING CLIPS -TYPE MOD. "E"	-
1	NEW CENTURY SWITCH STAND MODEL 50-B COMPLETE WITH 10'-0" OPERATING ROD & LATCHES & TARGET	3020
1	OPERATING ROD SUPPORT BRACKET	3007
3	16'-0" HEADBLOCKS (2 IF NO CIRCUIT CONTROLLER)	-
13	9'-0" SWITCH TIMBERS (14 " " " ")	-
6	10'-0" SWITCH TIMBERS	-

NOTES:

1. SINGLE POINT SPLIT SWITCH DERAIL CONSISTS OF ONE HALF OF A 16'-6" SWITCH LAID OUT FOR A NO. 8 TURNOUT.
2. SINGLE POINT SPLIT SWITCH DERAIL SHALL BE USED ON ALL SIDINGS WITH A DESCENDING GRADE TOWARDS THE MAIN LINE WHERE POSITIVE PROTECTION IS REQUIRED.
3. THE END OF THE DERAIL (WHERE THE DIVERGING RAIL ENDS, NOT THE SWITCH POINT) SHALL BE A MINIMUM DISTANCE OF 12 FEET FROM THE FOULING POINT OF THE MAIN LINE AND THIS DISTANCE SHOULD BE INCREASED IF CARS ROLLING ON THE SIDING COULD EXCEED 5 MPH DUE TO GRADE OR LENGTH OF GRADE ON THE SIDING.
4. OTHER TYPE TIE PLATES, SUCH AS TWIN HOOKS BEHIND THE HEEL MAY BE SUBSTITUTED IN PLACE OF RESILIENT FASTENER TYPE SHOWN, PROVIDED THAT DERAIL IS NOT IN MAIN TRACK.
5. SWITCH STAND TO BE COMPLETE WITH 10'-0" OPERATING ROD PER PLAN 3020-1 WITH TWO LATCHES AND TARGET

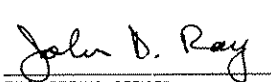
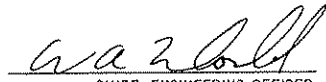
T	MASSACHUSETTS BAY TRANSPORTATION AUTHORITY	RAILROAD OPERATIONS	DWG. NO. 3006
			Oct. 28, 1992 ISSUE DATE
SPLIT SWITCH DERAIL		 ENGINEERING OFFICER	
		 CHIEF ENGINEERING OFFICER	

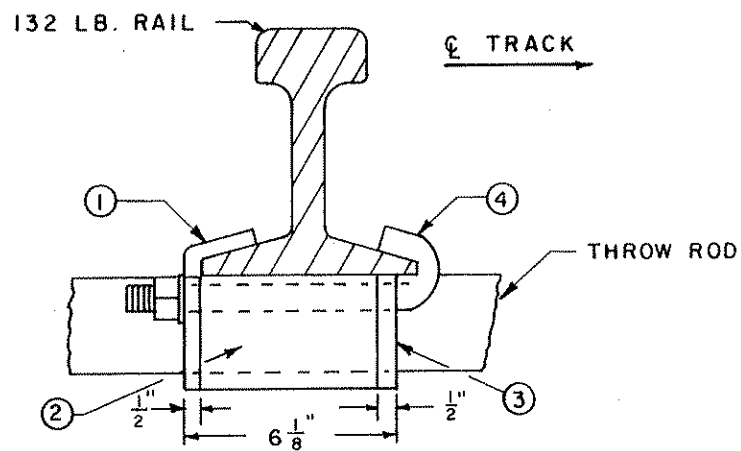

SIDE VIEW

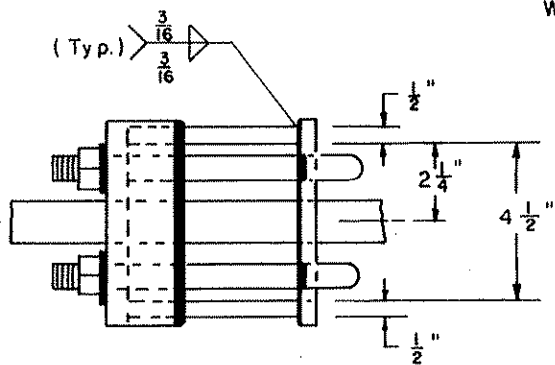

PLAN VIEW

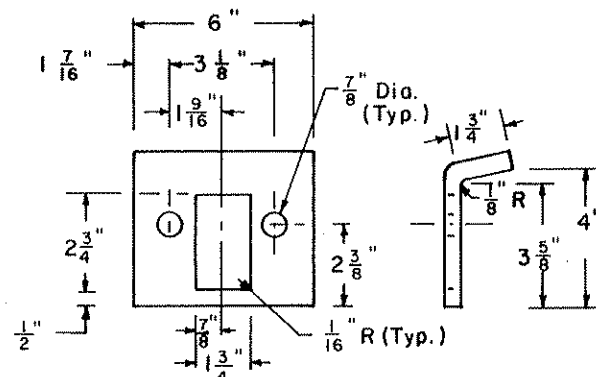

1 HEAD PLATE

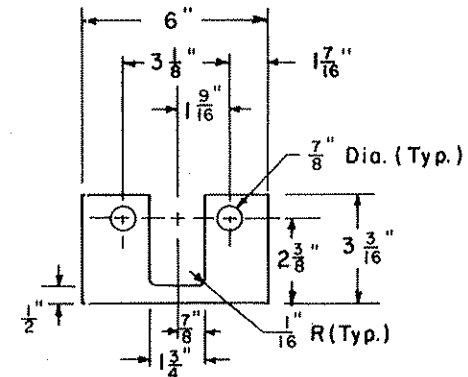

3 BACK PLATE

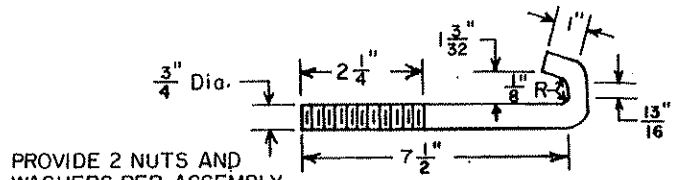

4 HOOK BOLT
2 REQ'D.

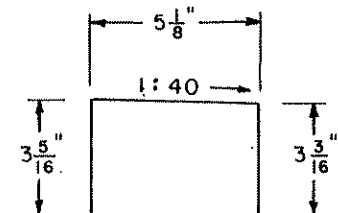

2 SIDE PLATE
(2 Required)

T MASSACHUSETTS BAY TRANSPORTATION AUTHORITY	RAILROAD OPERATIONS	DWG NO. 3007
		Oct. 28, 1992
OPERATING ROD SUPPORT BRACKET FOR SPLIT SWITCH DERAIL		1 ISSUE NO.
John D. Ray		W. A. ...
ENGINEERING OFFICER		CHIEF ENGINEERING OFFICER

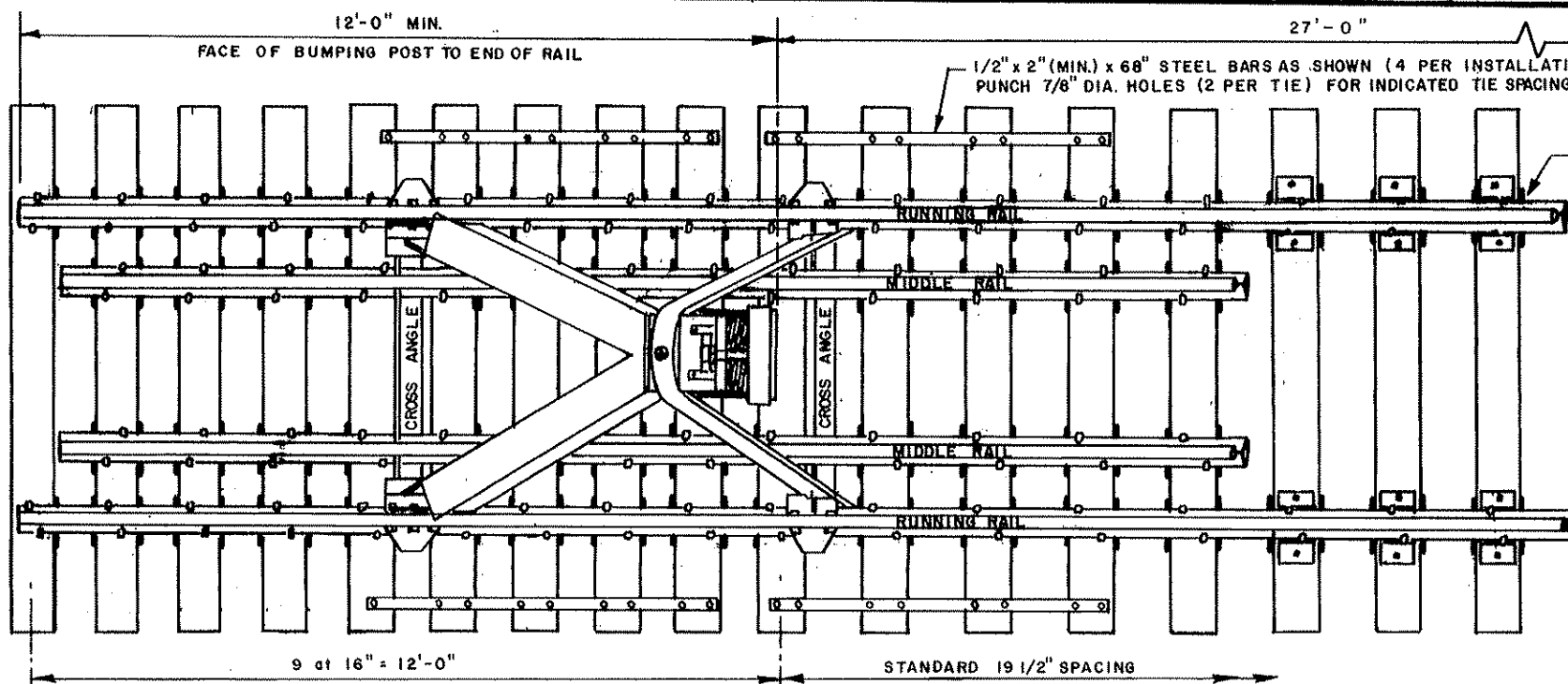

PLAN

INSULATED JOINTS

PROVIDE BOLTED POLY TYPE INSULATED JOINT ON ONE RAIL ONLY, 27'± (END OF RUNNING RAIL) FROM FACE OF BUMPING POST (IN SIGNALLED TRACK ONLY)

RAIL ANCHORS

BOX ANCHOR RUNNING RAILS AND MIDDLE RAILS ON EVERY TIE (EXCEPT WHERE CROSS ANGLES, ETC. PROHIBIT) AND FOR 200 FEET PAST FACE OF POST.

NOTES:

1. MODEL "WA" IS AN EXTRA HEAVY DESIGN (1655 lbs). USE ON ALL ENDS WHERE REVENUE PASSENGER SERVICE OPERATES EXCEPT AT MAJOR PASSENGER TERMINALS.
2. A MODEL "W-C SHOCK FREE" IMPACT ABSORBING HEAD (435 lbs) SHALL BE FURNISHED AND INSTALLED ON ALL BUMPING POSTS UNLESS OTHERWISE DIRECTED BY THE CHIEF ENGINEERING OFFICER.
3. END TIE PLATES 5 TIES AHEAD OF THE BUMPING POST.
4. THE MIDDLE RAILS SHOULD BE AT LEAST 19.5' LONG (1/2 RAIL LENGTH)
5. EACH RUNNING AND MIDDLE RAIL SHALL BE SPIKED TO EACH TIE WITH TWO CUT SPIKES (ONE ON EACH SIDE OF THE RAIL BASE).
6. THE INSTALLATION INSTRUCTIONS OF THE MANUFACTURER SHALL BE CAREFULLY & COMPLETELY FOLLOWED.
7. BUMPING POST SHOWN IS MANUFACTURED BY WESTERN-CULLEN-HAYES.

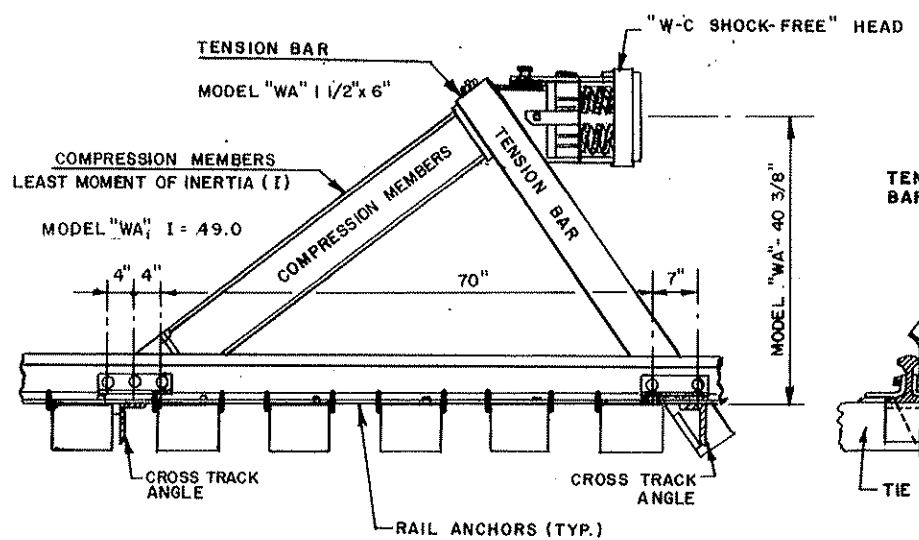

SIDE ELEVATION

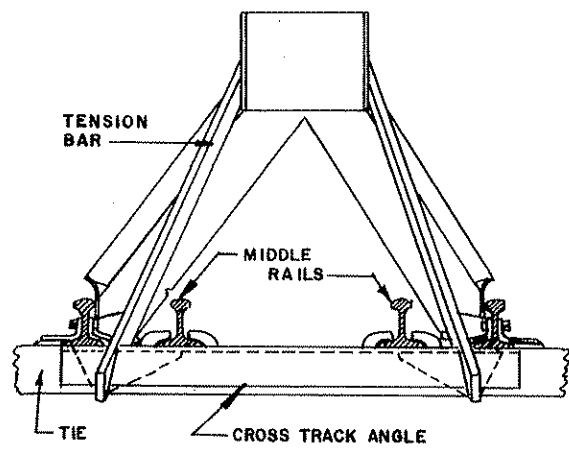

FRONT ELEVATION

	MASSACHUSETTS BAY TRANSPORTATION AUTHORITY	RAILROAD OPERATIONS	DWG. NO. 3010
			Oct. 28, 1992 <small>ISSUE DATE</small>

STEEL BUMPING POST

John D. Ray
 ENGINEERING OFFICER

W. A. ...
 CHIEF ENGINEERING OFFICER

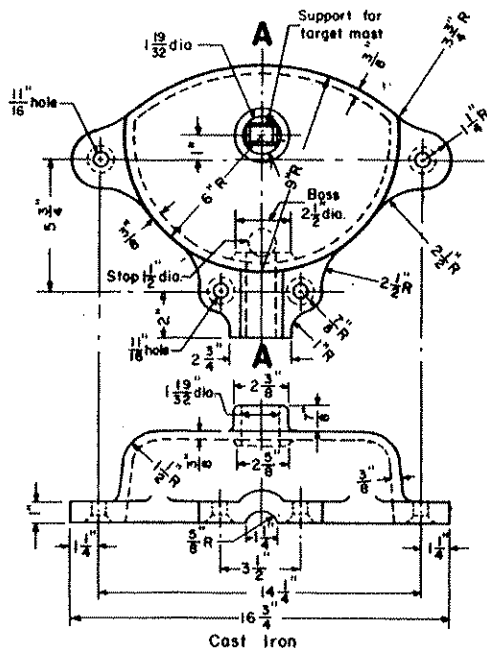

TOP OF SWITCH STAND-50A

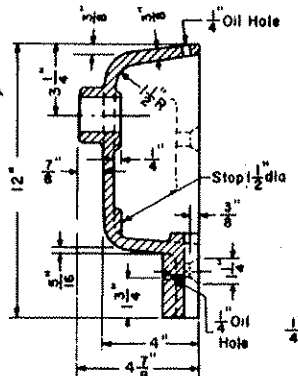

SECTION A-A

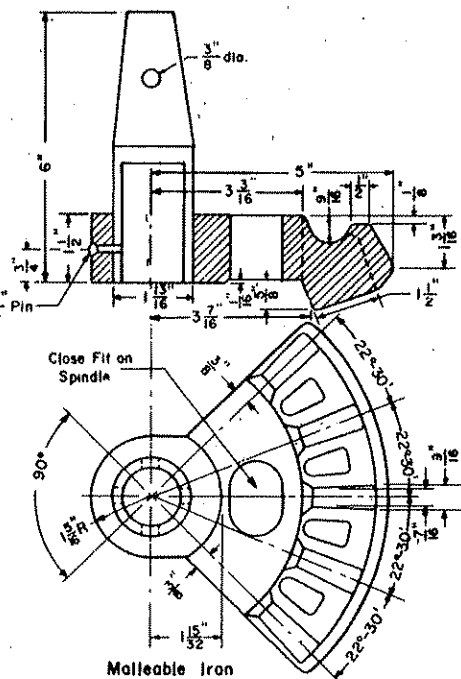

SEGMENT GEAR-50A or 50B

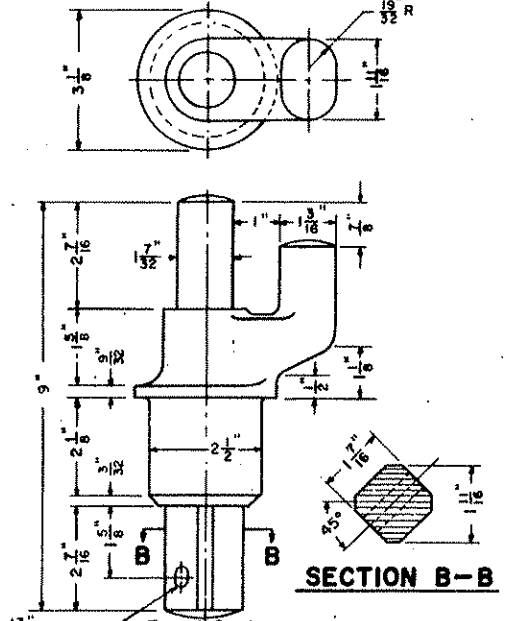

SPINDLE-50A or 50B

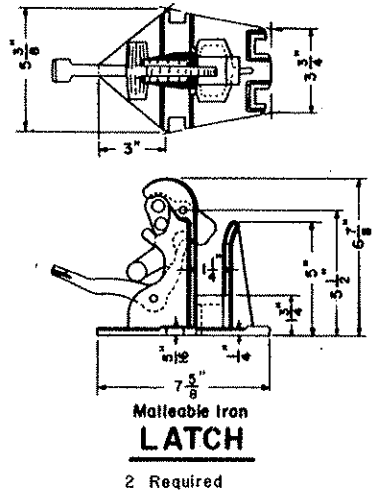

NOTES:

1. For additional details, see Plan 3020-2.
2. These switch stands are manufactured by Bethlehem Steel Corporation.
3. Model 50-A is a low type 10" high. Use in yards and terminals on switches that are not electrically locked and where there is limited clearance. Do not use on Mainline switches without specific authorization of the Chief Engineering Officer.
4. Model 50-B is an intermediate height stand. Use on Mainline switches and at all locations where there is sufficient side clearance for the required 16' long headblocks.
5. Throw in switch stand to be 5'.

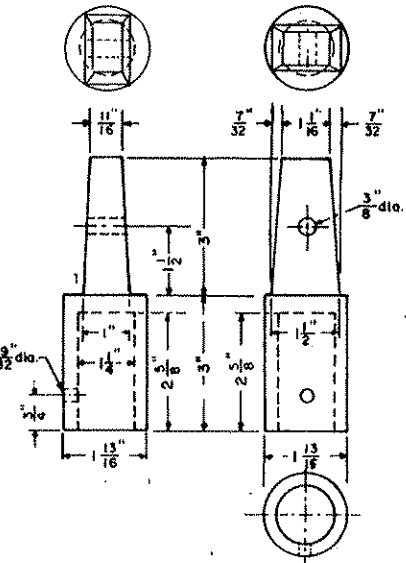

TARGET SUPPORT-50A

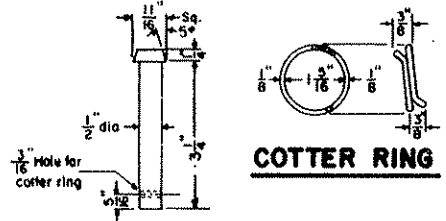

CROSS PIN

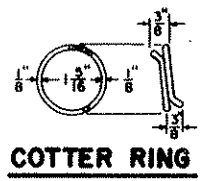

COTTER RING

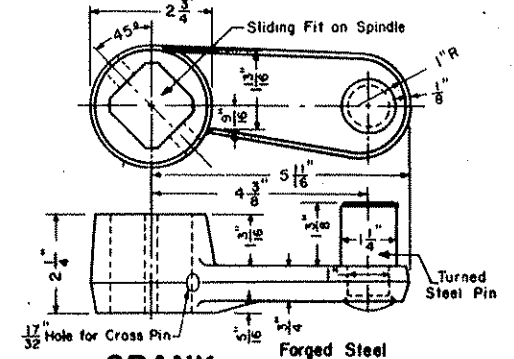

CRANK

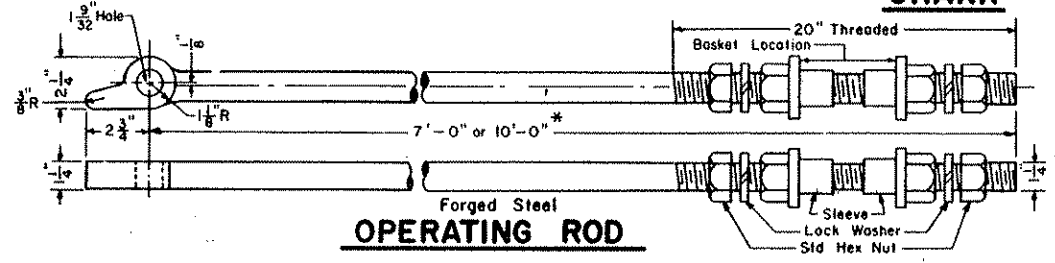

OPERATING ROD

*Provide 7'-0" rod with stand 50-A and 10'-0" rod with stand 50-B.

	MASSACHUSETTS BAY TRANSPORTATION AUTHORITY	RAILROAD OPERATIONS	DWG. NO. 3020-1 Oct. 28, 1992 ISSUE DATE	(2) ISSUE NO.
	NEW CENTURY SWITCH STAND INTERMEDIATE - MODEL 50-B AND LOW - MODEL 50-A			
<i>John D. Ray</i> ENGINEERING OFFICER		<i>W. A. ...</i> CHIEF ENGINEERING OFFICER		

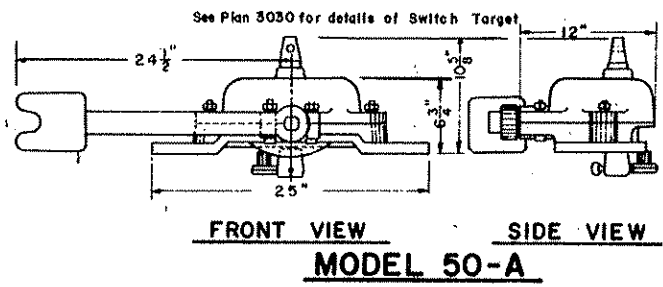
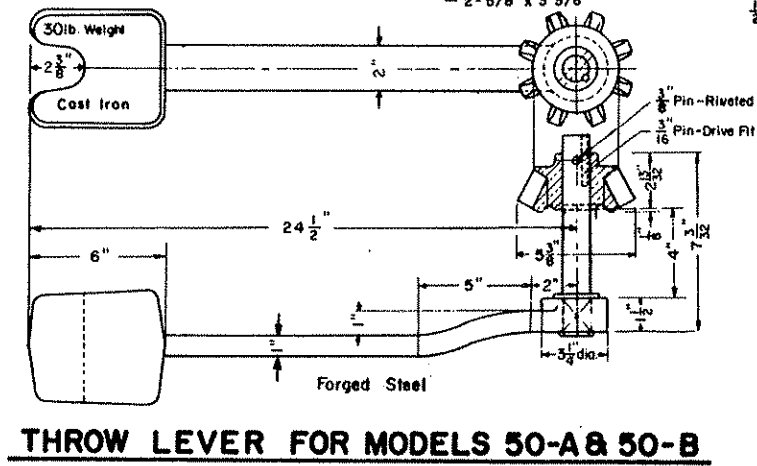
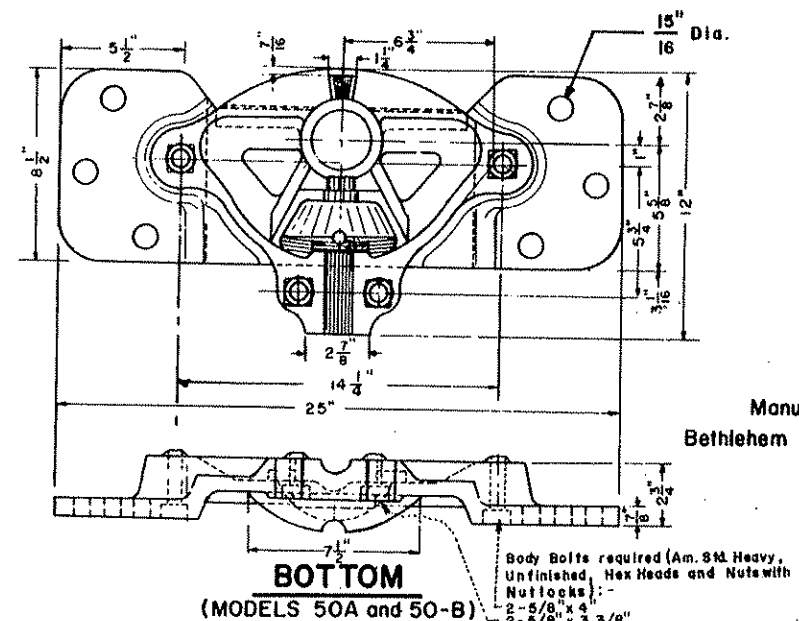
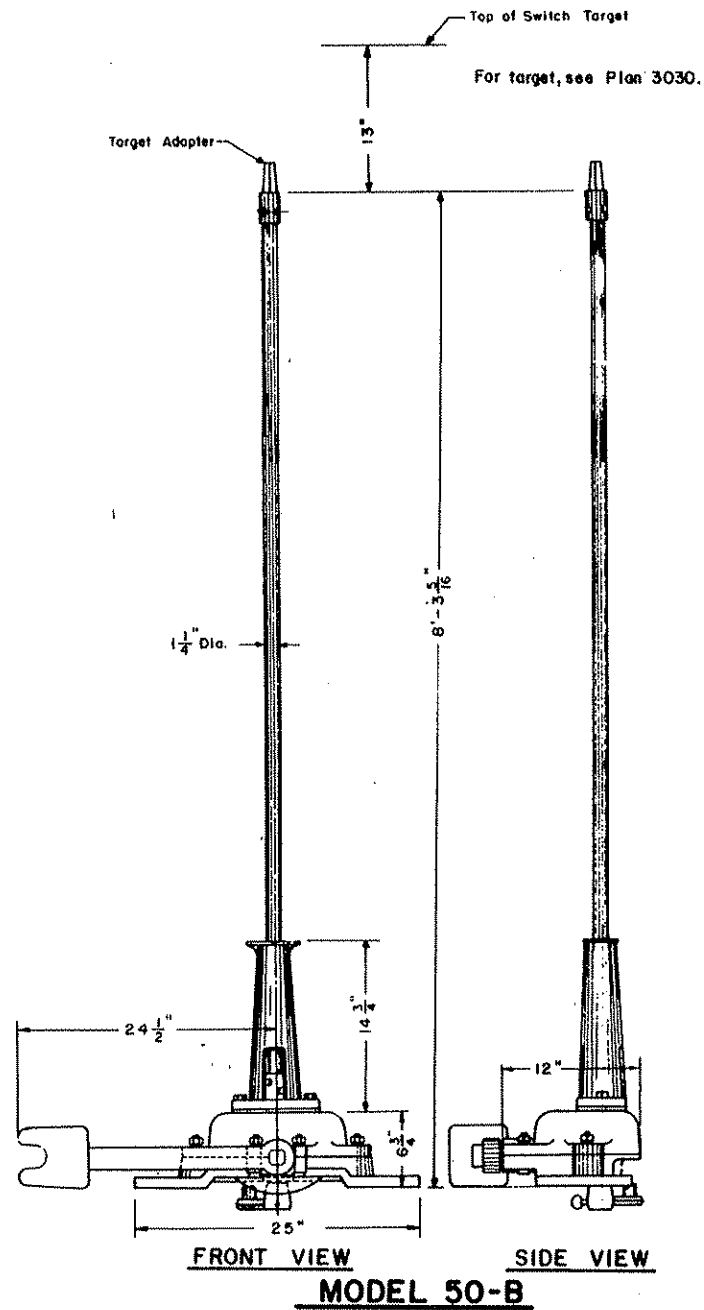

FOR ADDITIONAL DETAILS, SEE PLAN 3020-1.

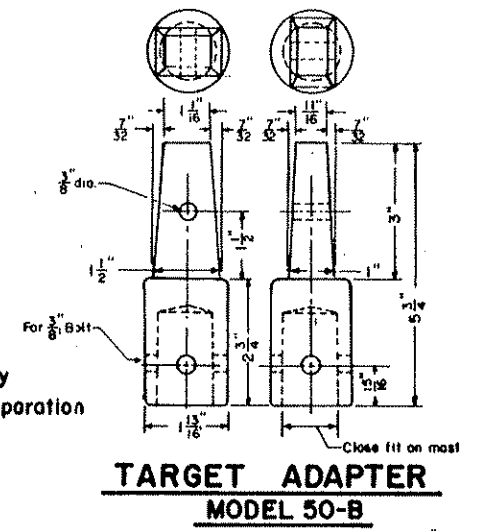

Manufactured By
Bethlehem Steel Corporation

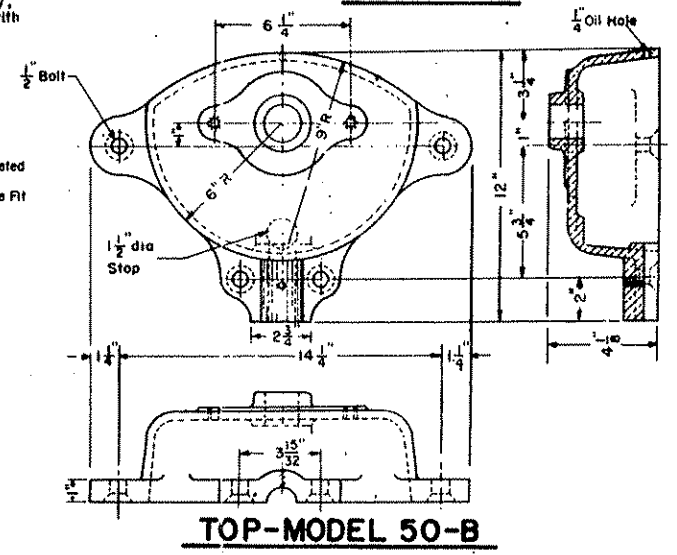

T	MASSACHUSETTS BAY TRANSPORTATION AUTHORITY	RAILROAD OPERATIONS	DWG. NO. 3020-2
			Oct. 28, 1932 ISSUE DATE
NEW CENTURY SWITCH STAND		AND	
INTERMEDIATE - MODEL 50-B		LOW - MODEL 50-A	
<i>John D. Ray</i>		<i>W. A. ...</i>	
ENGINEERING OFFICER		CHIEF ENGINEERING OFFICER	

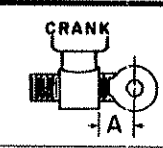
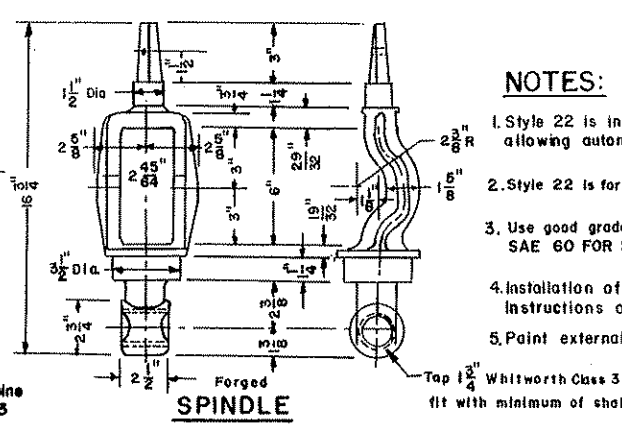
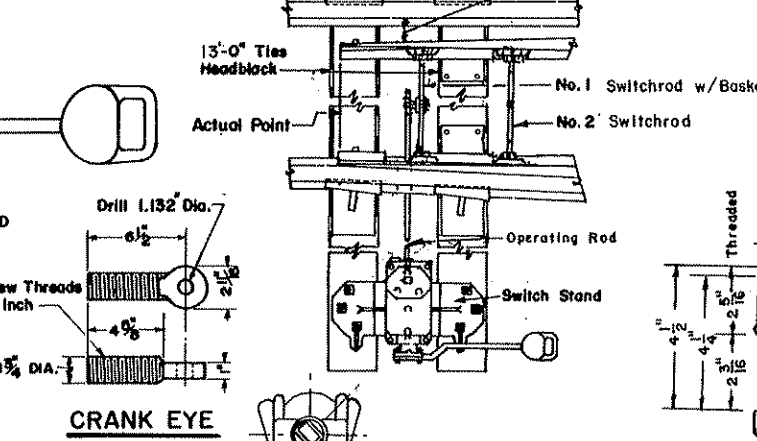
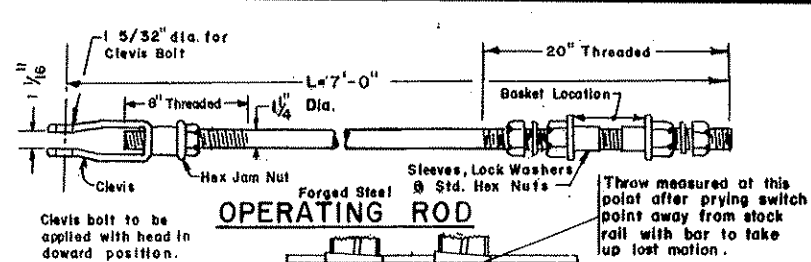
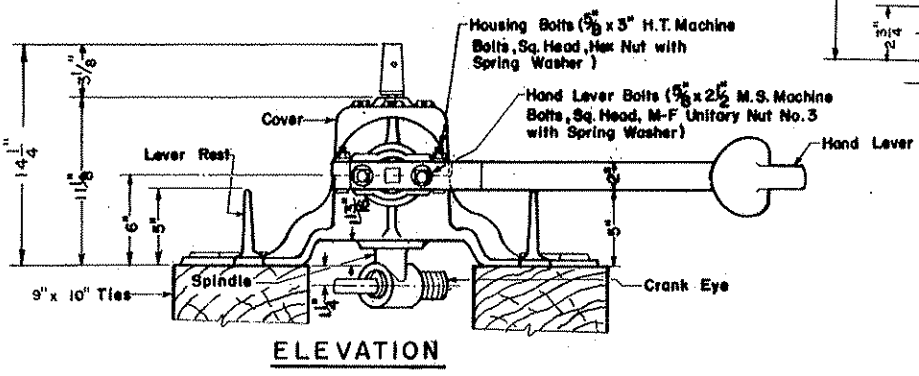
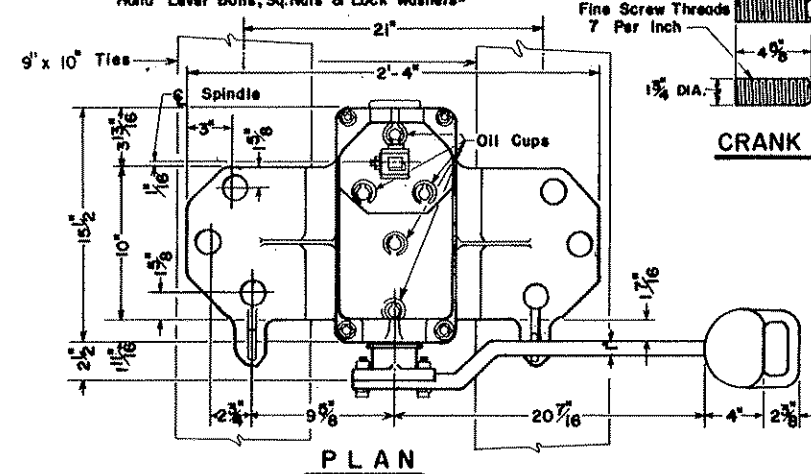
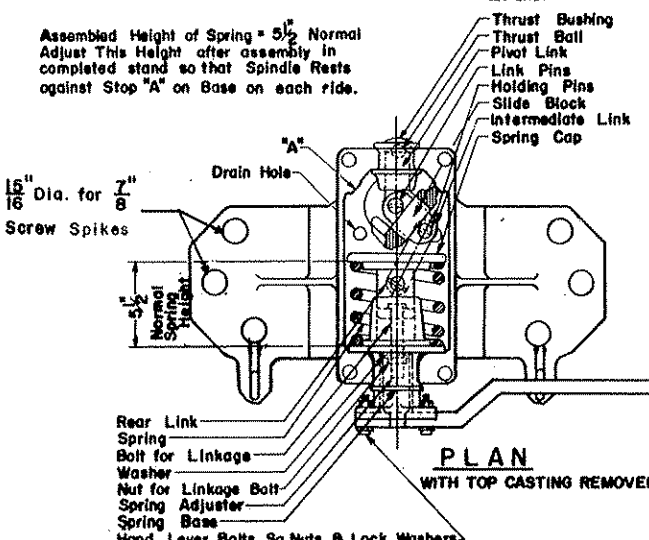

CRANK ADJUSTMENTS FOR RACOR SWITCH STANDS WITH SYMMETRICAL SPINDLE

Throw of Switch	A	Throw of Switch	A
4 1/2"	2 1/16"	5" Std.	2 7/16"
4 5/8"	2 3/16"	5 1/8"	2 1/2"
4 3/4"	2 1/4"	5 1/4"	2 5/8"
4 7/8"	2 5/16"	5 3/8"	2 11/16"
5"	2 7/16"	5 1/2"	2 13/16"

* Do not set crank less than 2 1/16", to avoid interference between clevis and spindle.

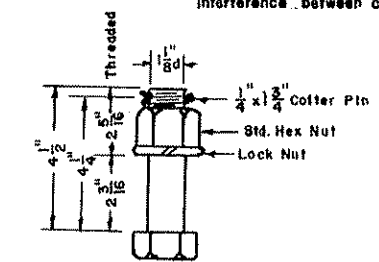

CLEVIS BOLT

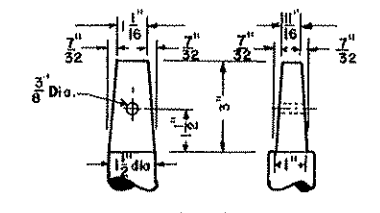

TOP OF SPINDLE DETAIL

- NOTES:
1. Style 22 is intended for use with "run through" switches allowing automatic operation of trailing point movements through the turnout.
 2. Style 22 is for use in Yard Tracks only.
 3. Use good grade of engine oil, with graphite content preferred. SAE 60 FOR SUMMER, SAE 40 FOR WINTER.
 4. Installation of this switch stand shall be carefully done, following the instructions of the manufacturer.
 5. Paint external surfaces with bright red/orange paint over primer.

MASSACHUSETTS BAY TRANSPORTATION AUTHORITY	RAILROAD OPERATIONS	DWG. NO. 3023 Oct. 28, 1992 ISSUE DATE	(2) ISSUE NO.
	LOW SWITCH STAND RACOR - STYLE - 22		
John D. Ray ENGINEERING OFFICER		W. A. H. [Signature] CHIEF ENGINEERING OFFICER	

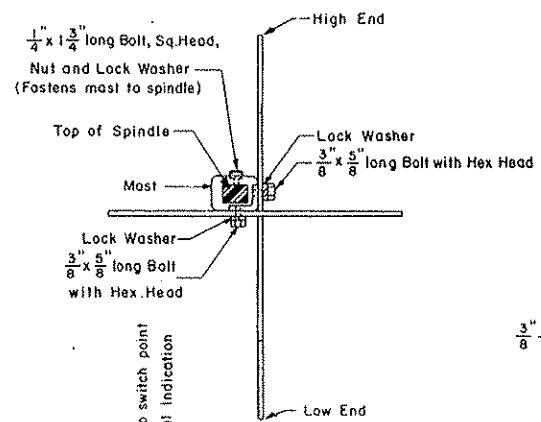

Pointing to switch point for Normal Indication
TOP VIEW

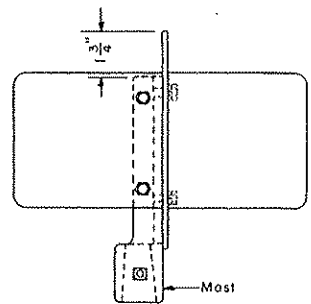

SIDE VIEW

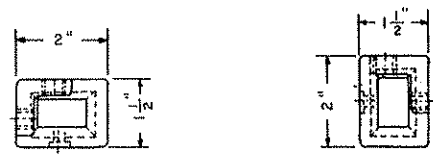

TOP VIEWS

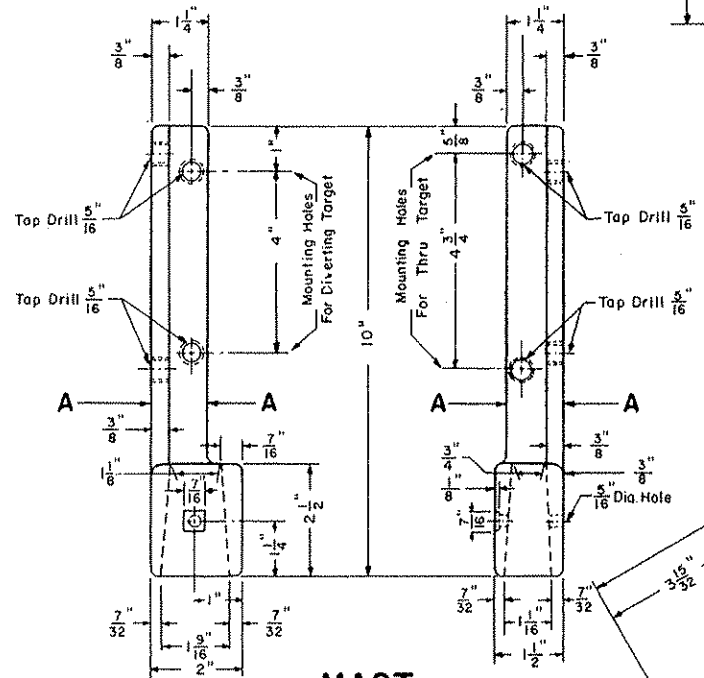

MAST
Cast Aluminum

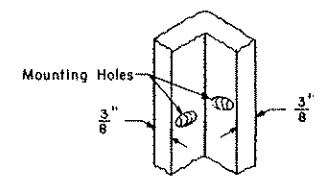

A-A
VIEW AT MOUNTING HOLES

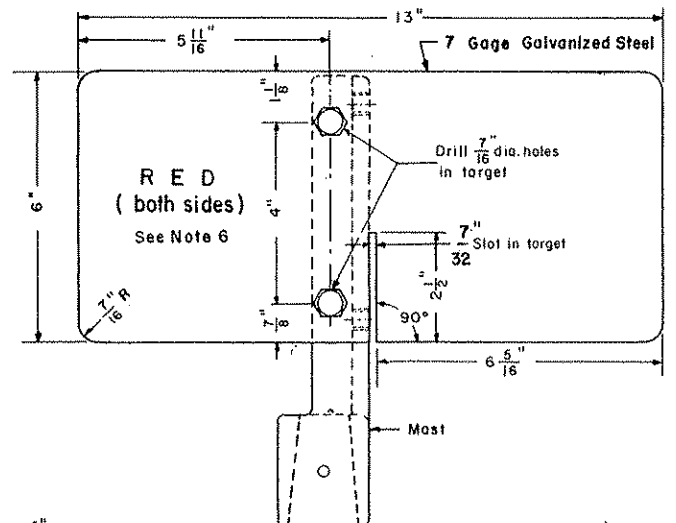

INDICATION - REVERSE
TARGET DETAIL

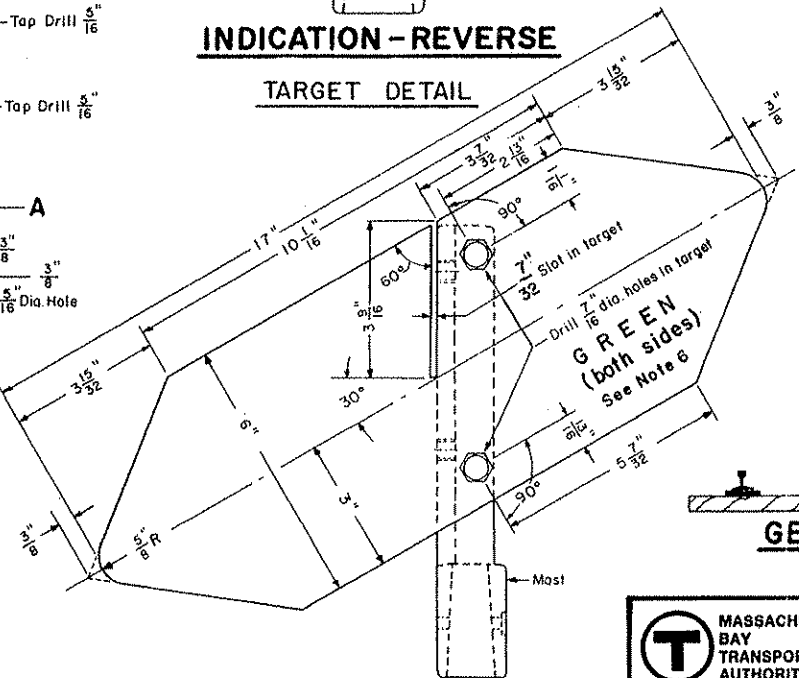

INDICATION - NORMAL
TARGET DETAIL

NOTES:

1. Targets shall be 7 gage Galvanized Steel Sheet.
2. All corners and edges of masts and targets shall have a smooth finish.
3. The steel surface of the targets shall be thoroughly cleaned with Oakite 33 before the application of reflectorized Scotchlite.
4. Scotchlite shall be applied to both surfaces following the manufacturer's instructions completely using a heat and vacuum process.
5. Care must be exercised when sliding targets into slots and fastening them to the mast to reduce the possibility of damaging the Scotchlite material.
6. **COLOR**
Red- No. 2872 Red Hi-Intensity Scotchlite
Green- No. 2877 Green Hi-Intensity Scotchlite

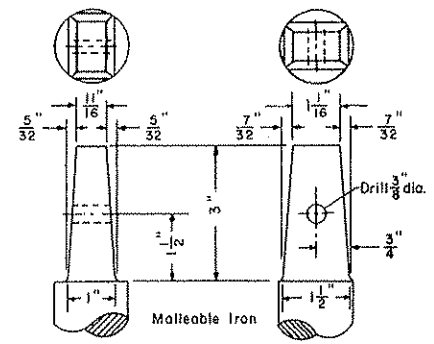

TOP OF SPINDLE

Upward point shall always point away from track when switch is set normal for thru movement



GENERAL APPLICATION

T MASSACHUSETTS BAY TRANSPORTATION AUTHORITY	RAILROAD OPERATIONS	DWG. NO. 3030
		Oct. 28, 1992 (2)
	ISSUE DATE	ISSUE NO.

SWITCH STAND TARGET

John D. Ray
ENGINEERING OFFICER

W. A. [Signature]
CHIEF ENGINEERING OFFICER

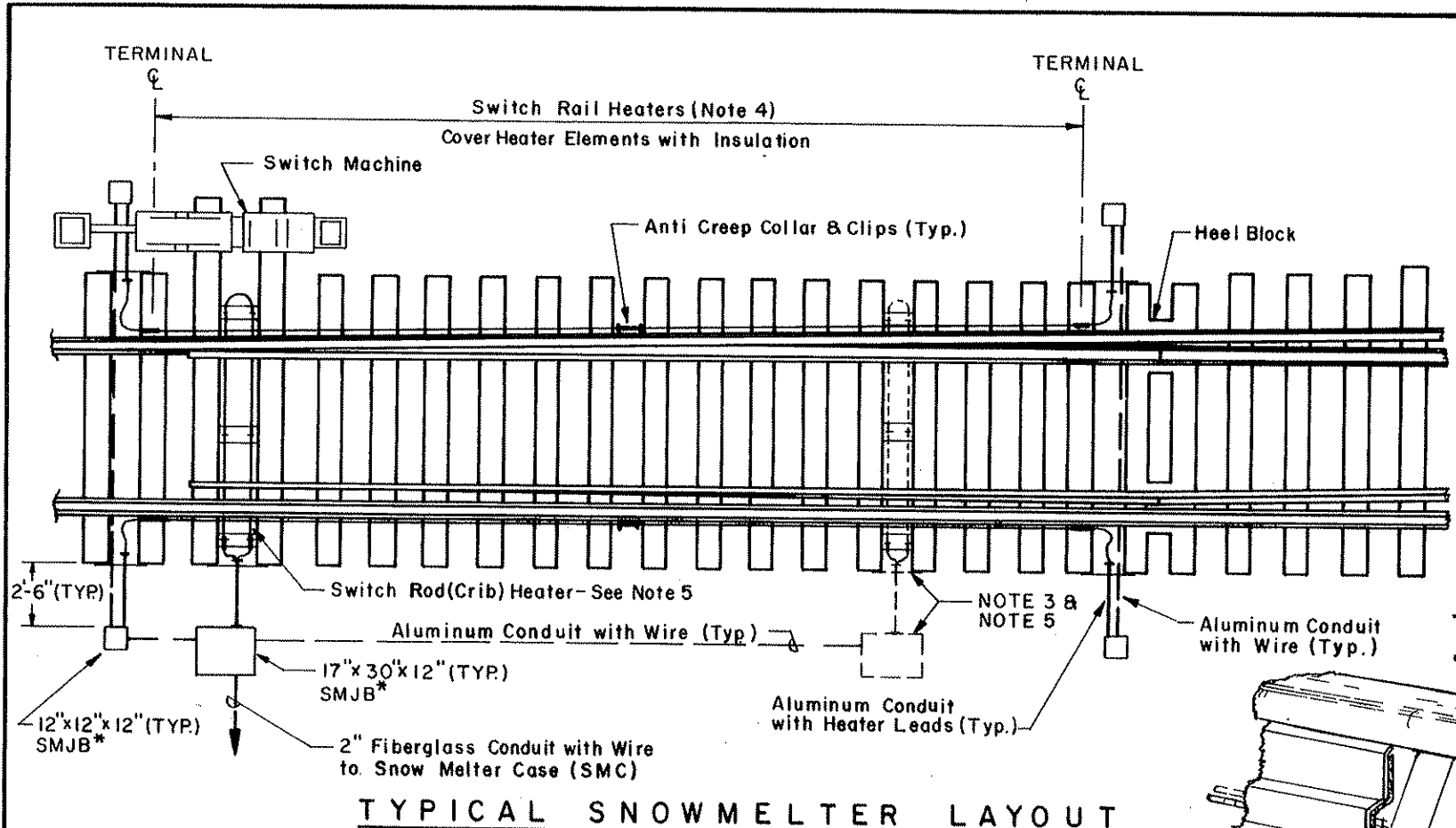

- NOTES:**
1. All mounting hardware including snap-on clips, bolts, nuts and washers shall be hot dipped galvanized or stainless steel.
 2. All snowmelter elements shall be provided complete with fastening hardware.
 3. For a No. 20 layout, add a crib heater in the helper rod bay and a snow melter junction box.
 4. At operationally critical locations, dual switch rail and crib heaters shall be installed as directed.
 5. Brackets supporting the crib heaters shall be installed 5 1/2" below the base of rail. The area under the crib heaters must be clear and sloped for drainage of the crib.

- LEGEND**
- SMJB = Snowmelter Junction Box
 - = Aluminum Conduit with Heater Leads
 - = Aluminum/Fiberglass Conduit with Wire
 - = Switch rod/Rail Heaters with Sealed Terminals

TYPICAL SNOWMELTER LAYOUT

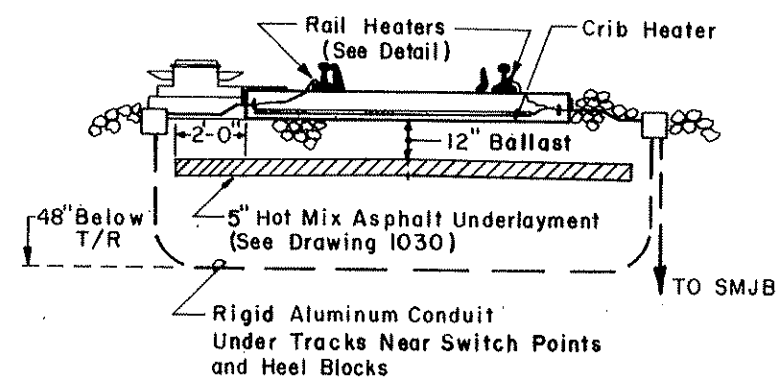

TYPICAL SECTION

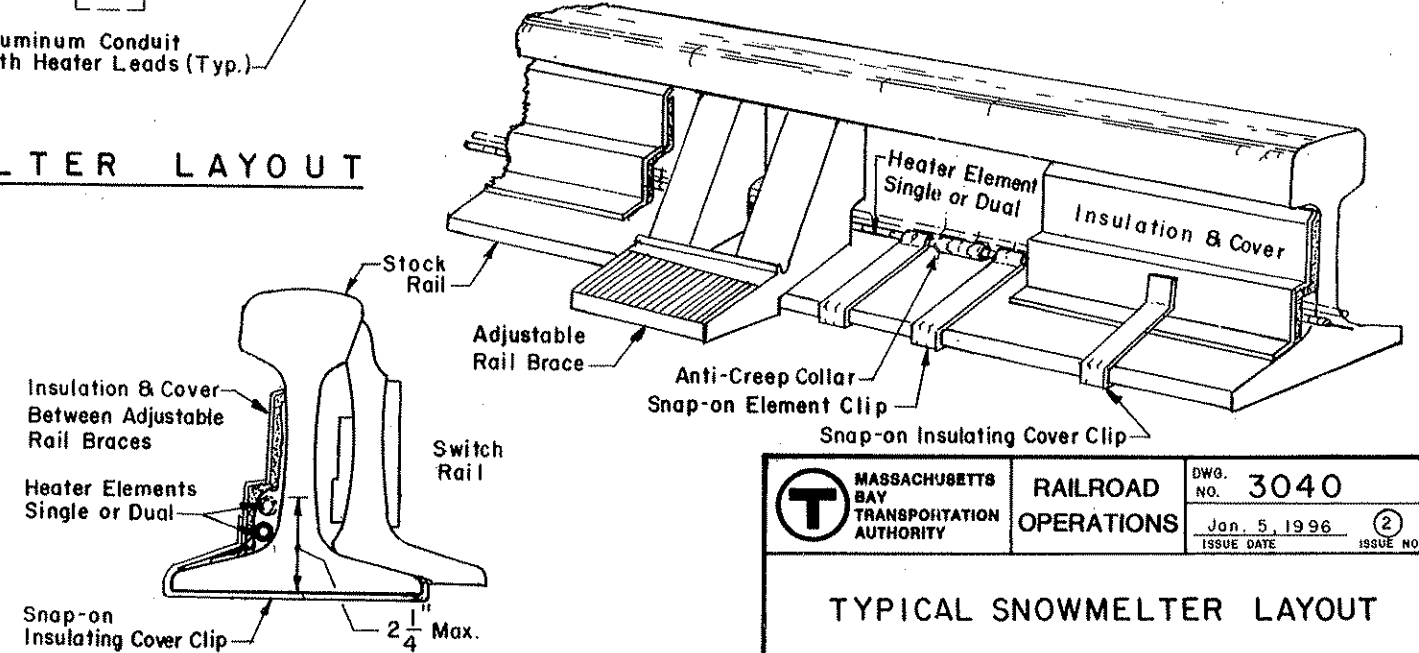

DETAIL AT RAIL HEATER INSTALLATION

T MASSACHUSETTS BAY TRANSPORTATION AUTHORITY	RAILROAD OPERATIONS	DWG. NO. 3040
		Jan. 5, 1996 ② ISSUE DATE ISSUE NO.

TYPICAL SNOWMELTER LAYOUT

John D. Ray
SECTION CHIEF

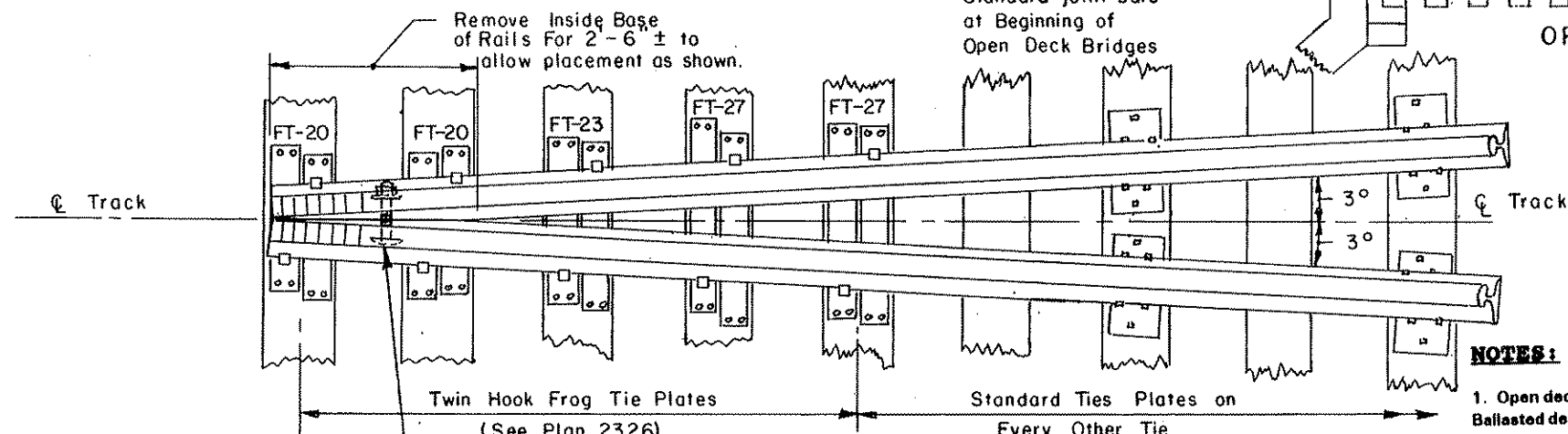
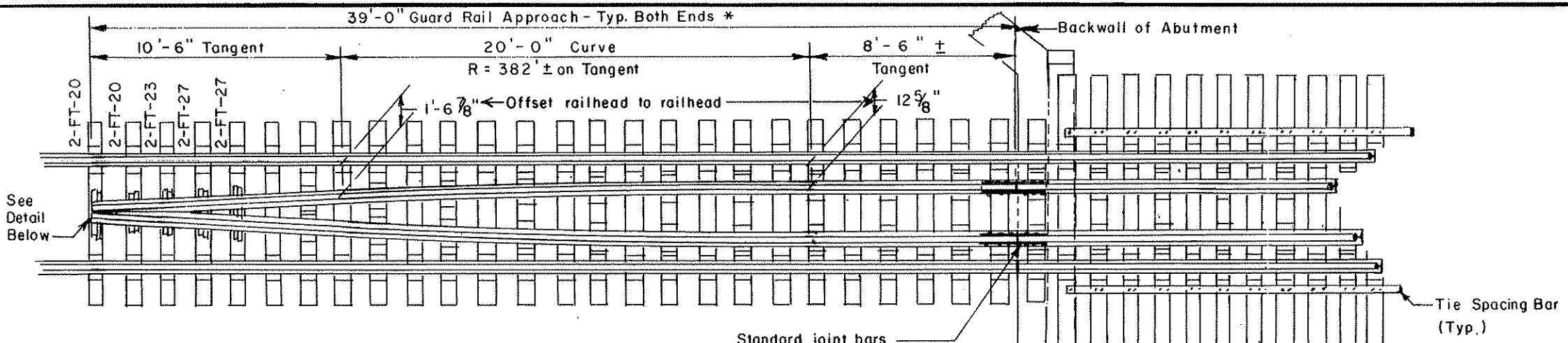

NOTES:

1. Open deck bridge may use cut spike fastened guard rail tie plates as shown. Ballasted deck bridges shall use resiliently fastened plates as shown on Drawing 3062.
2. Guard rails shall be used on all through girder and through truss bridges regardless of span length and on any bridge where the structure length exceeds 40 feet.
3. Guard rails shall be plated on every other tie but otherwise shall be fully spiked and jointed with 36" joint bars the same as with running rails.

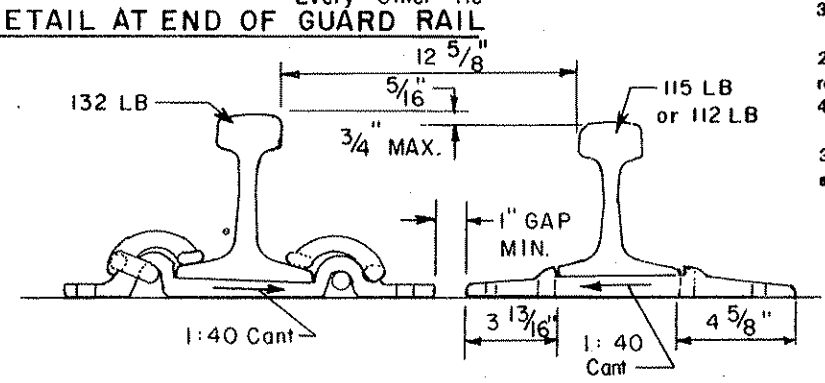
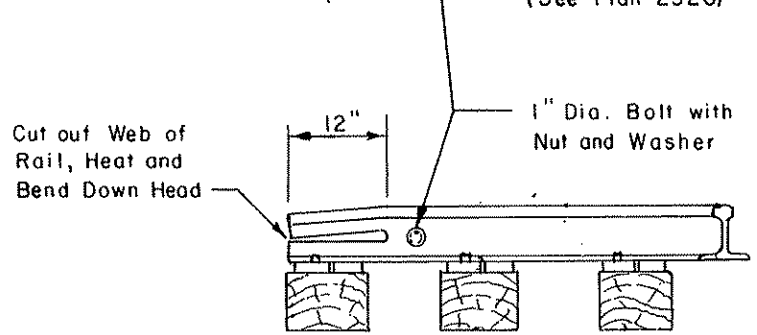

Turn Guard Rail Plates so that narrow shoulder is towards running rail

T MASSACHUSETTS BAY TRANSPORTATION AUTHORITY	RAILROAD OPERATIONS	DWG. NO. 3060
		Jan. 5, 1998
		ISSUE DATE
		ISSUE NO. 3

GUARD RAIL ON BRIDGES

John D. Ray
SECTION CHIEF

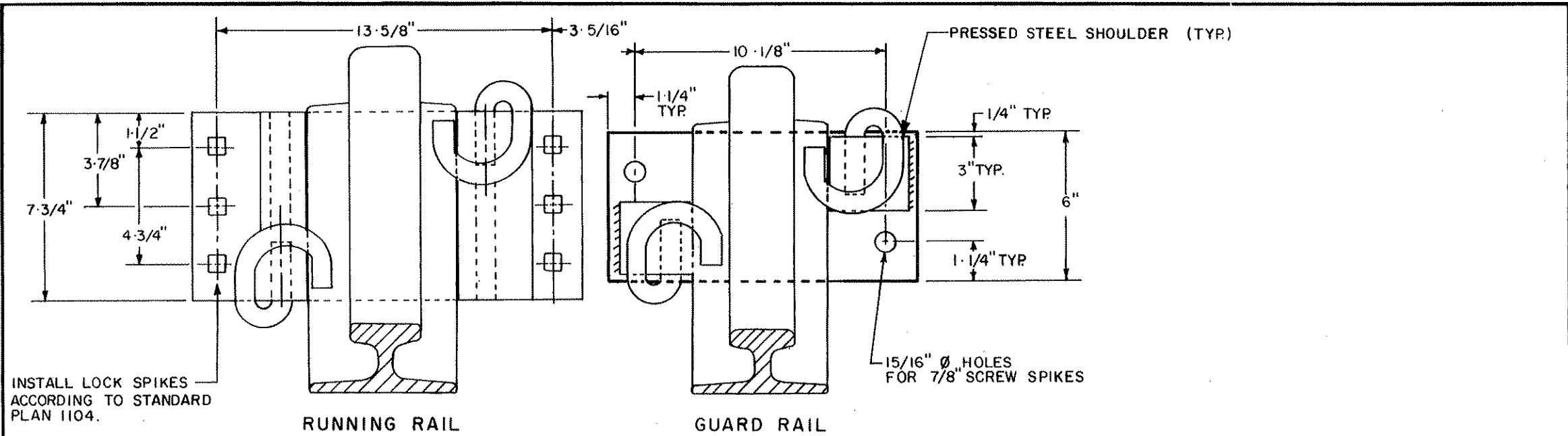

NOTES:

1. This installation shall be used on ballasted deck bridges with timber ties.
2. For additional details of guard rail installation, see Drawing No. 3060.
3. Tie plates shall conform to current AREA specifications.
4. Guard rail plates shall be branded to designate the section, three letters or a trademark to indicate the producer and two figures being the last year rolled. Lettering shall be on the gage side of the plate.
5. Material shall be ASTM A-36 steel.
6. Guard rail railseats shall be placed on every other tie unless otherwise specified.
7. Welds shall be made so as not to interfere with the installation of the rail or the rail clips.

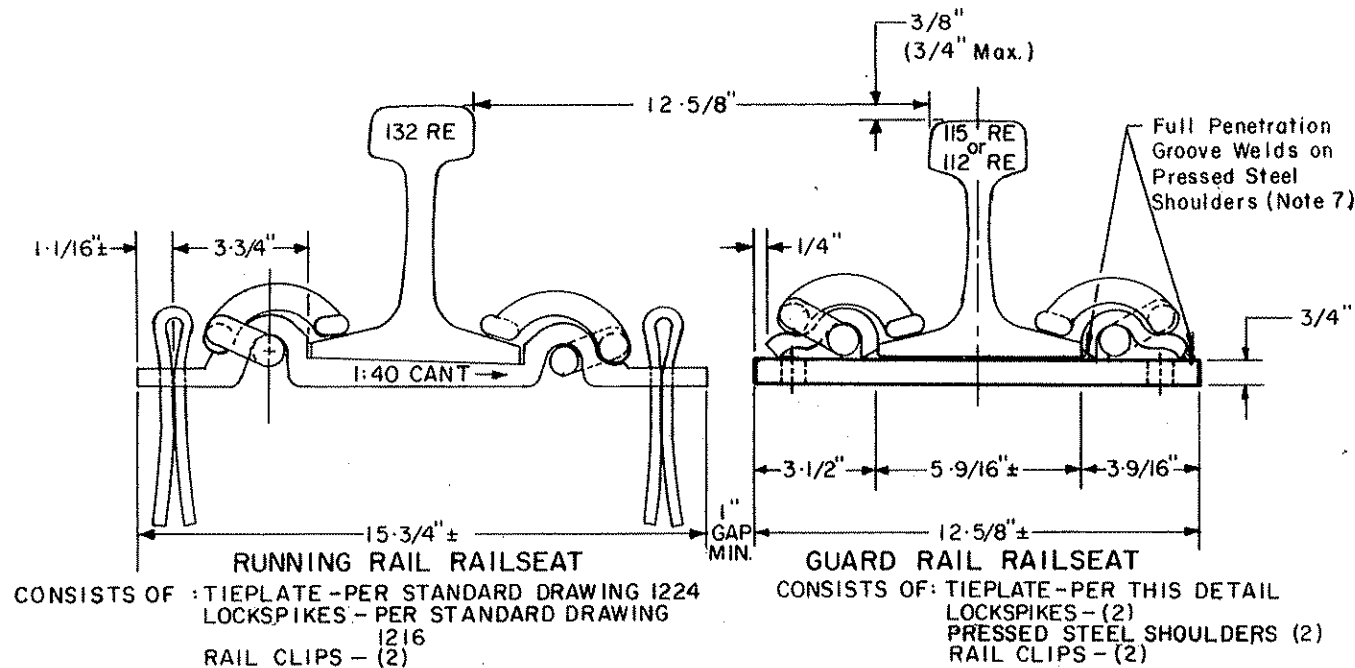

T	MASSACHUSETTS BAY TRANSPORTATION AUTHORITY	RAILROAD	DWG. NO. 3062
		OPERATIONS	Jan. 5, 1996 ② <small>ISSUE DATE ISSUE NO.</small>

**RESILIENTLY FASTENED
BRIDGE GUARD RAIL**

John D. Ray
 SECTION CHIEF

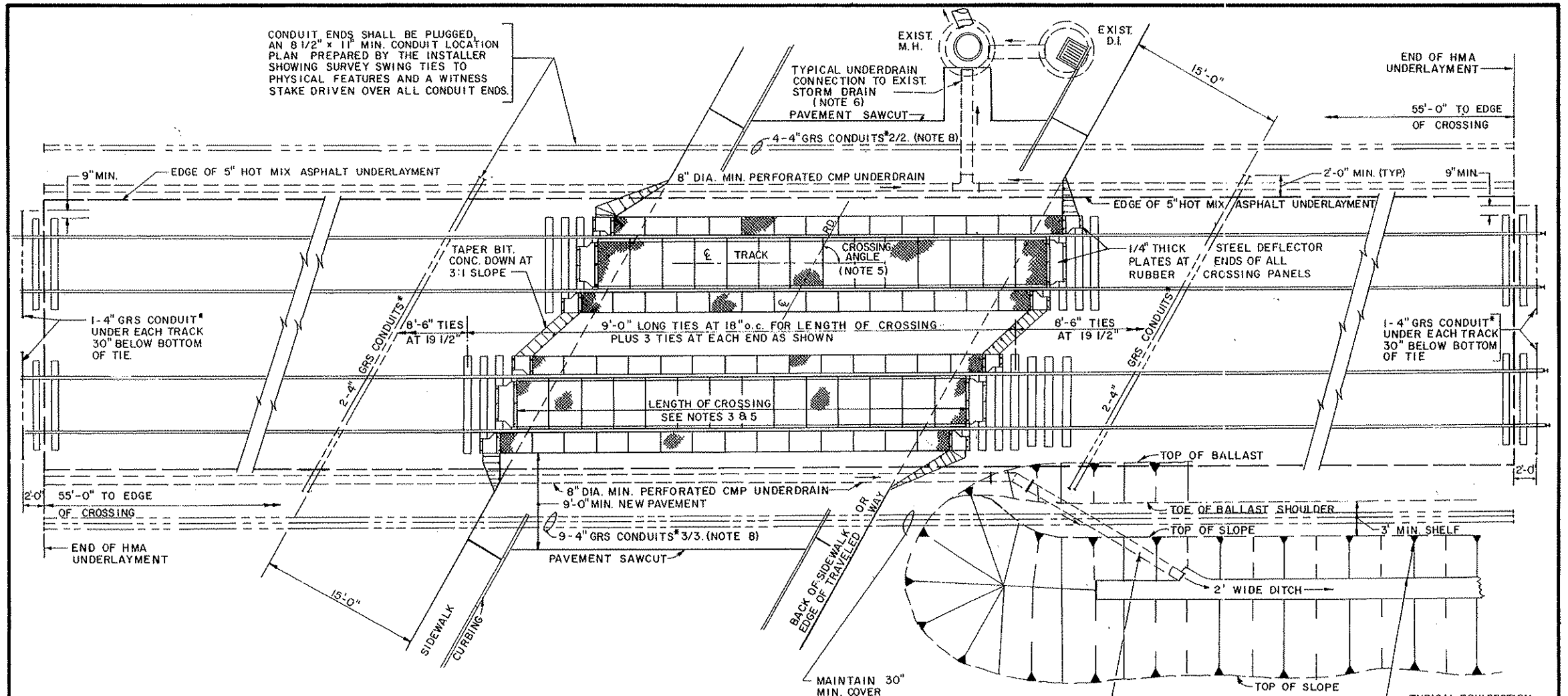

CONDUIT ENDS SHALL BE PLUGGED, AN 8 1/2" x 11" MIN. CONDUIT LOCATION PLAN PREPARED BY THE INSTALLER SHOWING SURVEY SWING TIES TO PHYSICAL FEATURES AND A WITNESS STAKE DRIVEN OVER ALL CONDUIT ENDS.

TYPICAL UNDERDRAIN CONNECTION TO EXIST. STORM DRAIN (NOTE 6)
PAVEMENT SAWCUT

NOTES:

1. Full depth rubber crossing surface shown is for use on all primary road crossings. Low traffic volume installations to use rubber rail seal with bituminous surface.
2. For section and additional details of full depth rubber crossing, see Dwg. No. 3106. For rubber rail seal crossing, see Dwg. No. 3108.
3. Length of crossing to be the first multiple of 3' beyond the edge of traveled way (back of sidewalk) on each end.
4. Full depth rubber crossing surfaces shall be of a design which allows installation without bolting or lagging from the top surface into the ties. All crossing material must be designed to install over the standard resilient fastener system.
5. Stagger the crossing panels (as shown) in multiples of 18" (tie spacing) when the crossing angle is less than 65° ±.

6. Underdrains should outlet to either R.O.W. ditches or exist. storm drains. If either method is not possible, consider a drywell.
7. Do not use subgrade underdrains to carry water in ditches through the crossing area. Use separate storm drains for this purpose.
8. The side of R.O.W. to receive the 9 GRS conduits to be determined by Chief Engineering Officer. The 3 top conduits shall extend 10' beyond the edges of roadway, 6 bottom conduits shall extend to ends of HMA slab.

* GRS = Galvanized Rigid Steel (conduit).

	RAILROAD OPERATIONS	DWG. NO. 3100 Oct. 28, 1992 <small>ISSUE DATE</small>	1 <small>ISSUE NO.</small>
	GRADE CROSSING LAYOUT		
<i>John D. Ray</i> <small>ENGINEERING OFFICER</small>		<i>W. A. Z. ...</i> <small>CHIEF ENGINEERING OFFICER</small>	

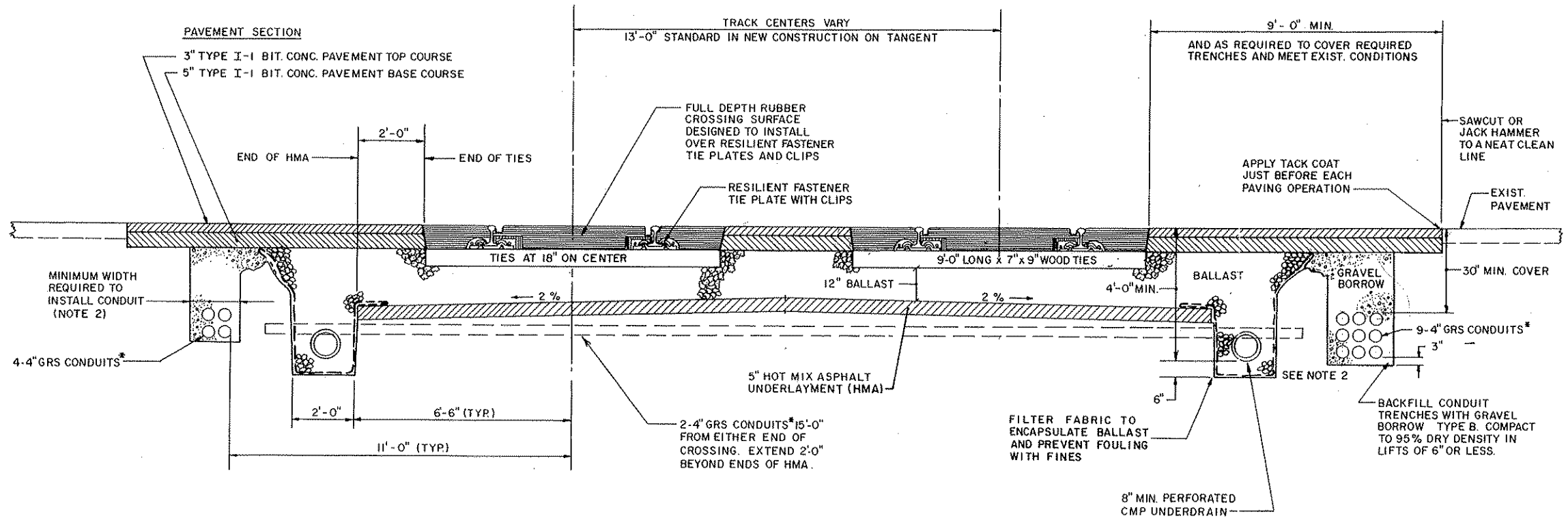

NOTES:

1. For plan of typical crossing, see drawing 3100.
 2. To minimize settlement, keep excavation for underdrains and conduits to a minimum. Compact backfill in lifts not exceeding 6" to 95% of maximum dry density.
 3. If soil or drainage conditions at the site are poor, the designer must obtain subsurface data and design subgrade and drainage modifications which may differ from what is shown on this standard design.
- GRS = Galvanized Rigid Steel (conduit).

 MASSACHUSETTS BAY TRANSPORTATION AUTHORITY	RAILROAD OPERATIONS	DWG. NO. 3106
	Oct. 28, 1992 1 <small>ISSUE DATE ISSUE NO.</small>	
<p>TYPICAL SECTION FULL DEPTH RUBBER CROSSING</p> <p style="font-family: cursive; font-size: 1.2em;">John D. Ray W. A. ...</p> <p style="font-size: 0.8em;">ENGINEERING OFFICER CHIEF ENGINEERING OFFICER</p>		

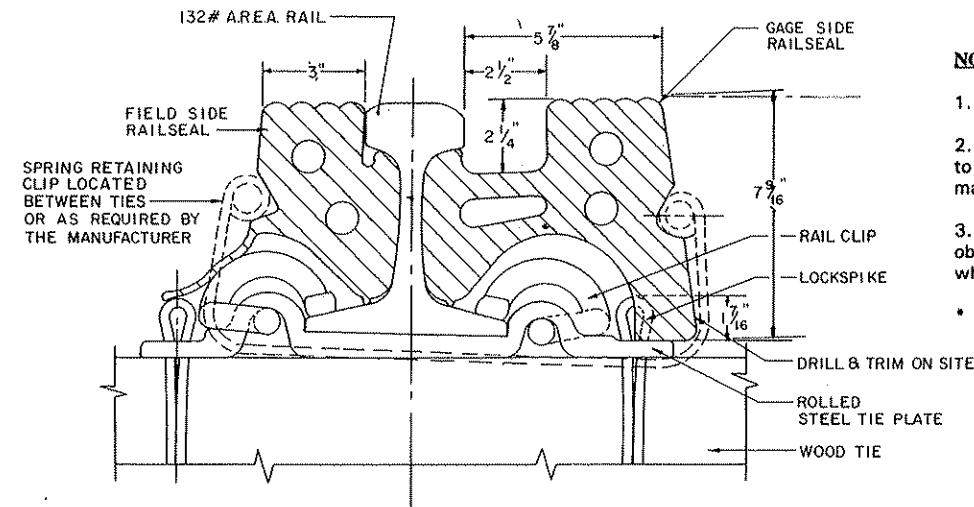
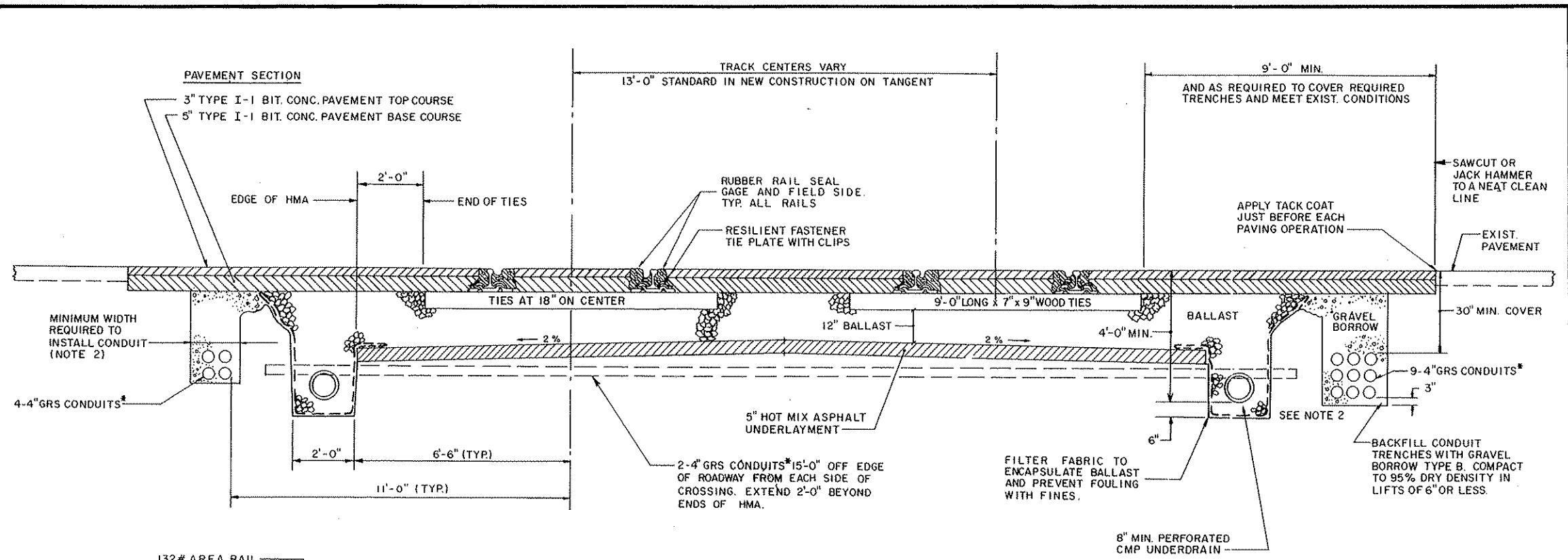

DETAIL AT RAIL SEAL
DIMENSIONS ARE FOR 132 LB RE RAIL

NOTES:

1. For plan of typical crossing, see drawing 3100.
2. To minimize settlement, keep excavation for underdrains and conduits to a minimum. Compact backfill in lifts not exceeding 6" to 95% of maximum dry density.
3. If soil or drainage conditions at the site are poor, the designer must obtain subsurface data and design subgrade and drainage modifications which may differ from what is shown on this standard design.

* GRS = Galvanized Rigid Steel (conduit).

T	MASSACHUSETTS BAY TRANSPORTATION AUTHORITY	RAILROAD OPERATIONS	DWG. NO. 3108
			Oct. 28, 1992 ISSUE DATE
TYPICAL SECTION RUBBER RAIL SEAL CROSSING		<i>John D. Reay</i> ENGINEERING OFFICER	<i>W. A. ...</i> CHIEF ENGINEERING OFFICER

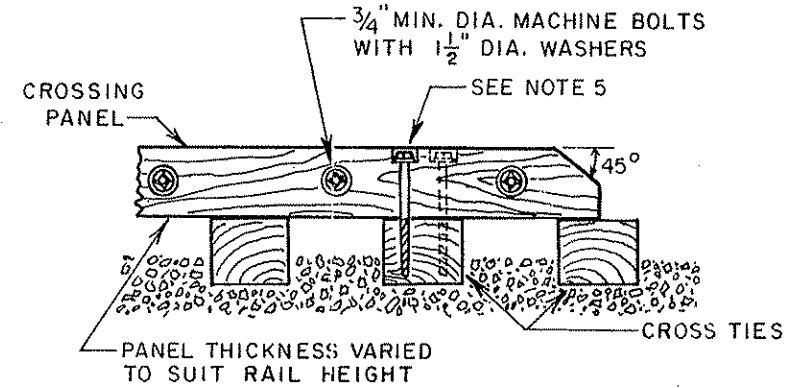
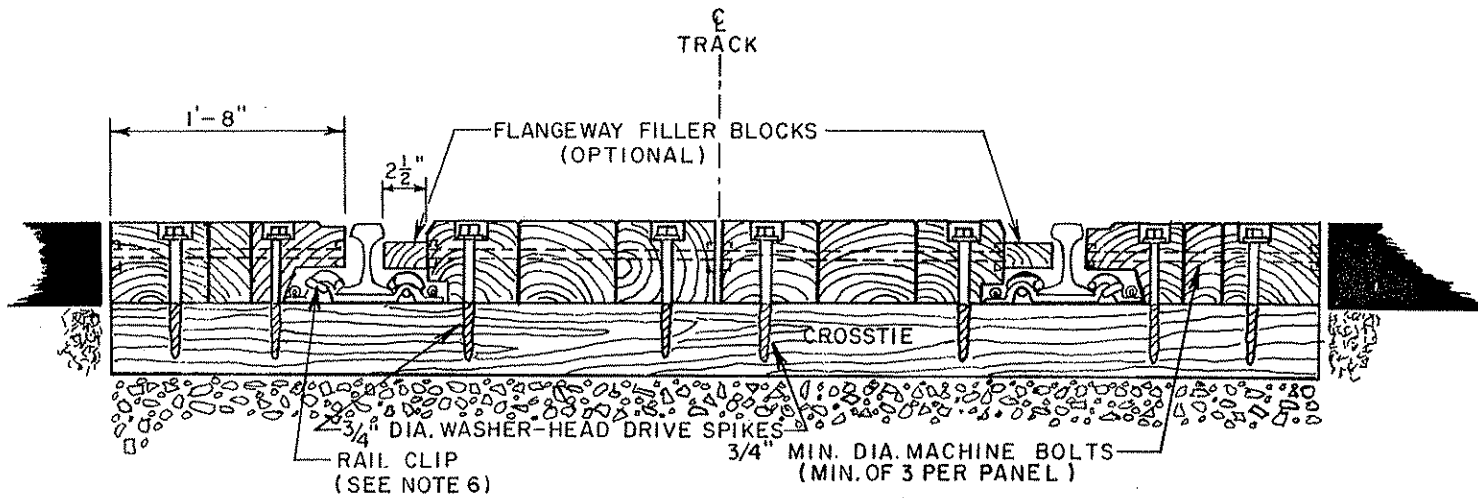
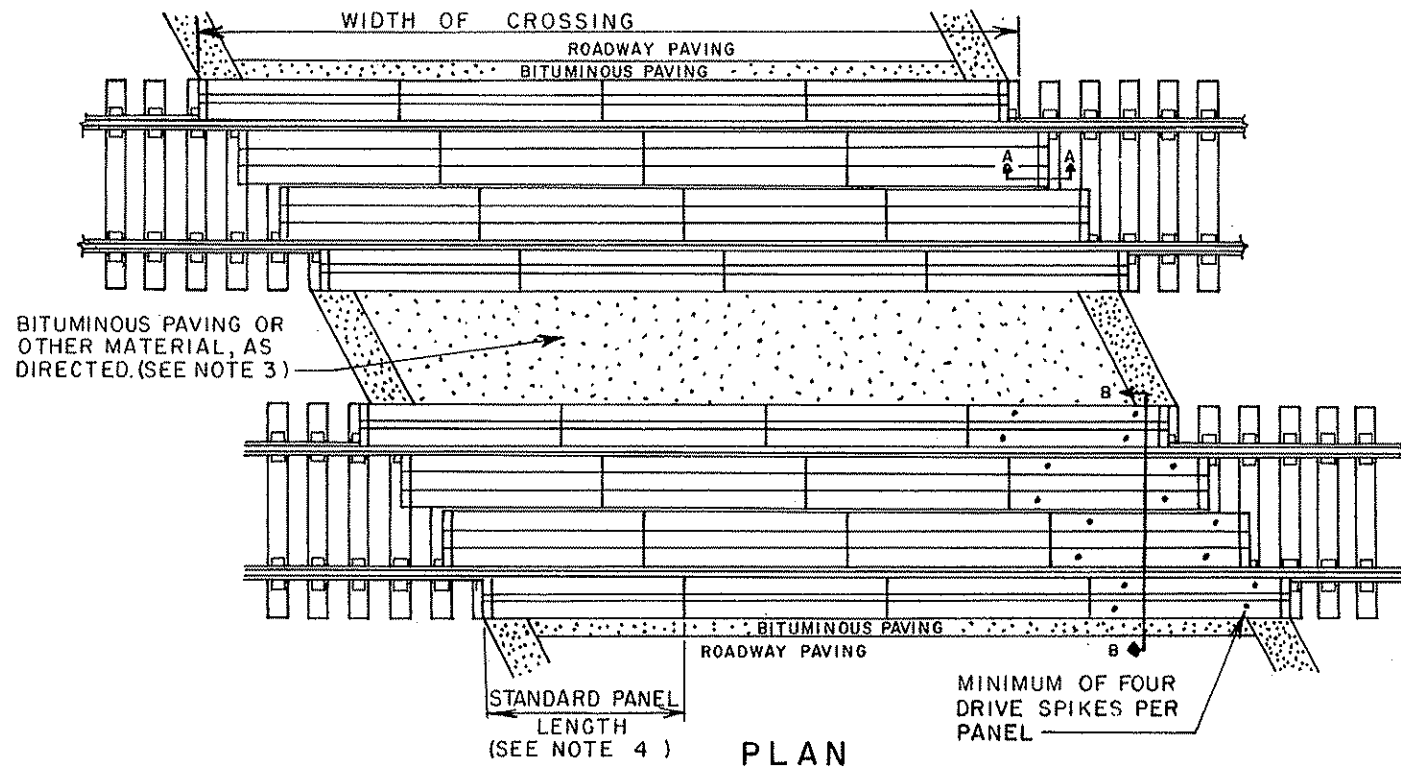

SIDE VIEW OF END PANEL
Section A-A

NOTES:

1. Timber grade crossing is to be used as a temporary crossing only, as directed or approved by the Chief Engineer.
2. When grade crossing is removed, spike holes shall be treated and plugged.
3. When the grade crossing contains multiple tracks, the paving material between the tracks shall be approved by the Chief Engineer.
4. Standard panel lengths are 8'-0" and 6'-4 3/4". Additional lengths are attained through multiples of these basic units.
5. Crossing panels to be bored in the field to fit existing tie spacing.
6. Timber panels to be manufactured to clear resilient track fastening system. Rail clip type and/or number to be provided to grade crossing supplier.
7. Timber panels shall be treated with creosote preservative as per A.R.E.A., Chapter 3.

T	MASSACHUSETTS BAY TRANSPORTATION AUTHORITY	RAILROAD OPERATIONS	DWG. NO. 3120
			Oct. 28, 1992 1 ISSUE DATE ISSUE NO.
TEMPORARY TIMBER GRADE CROSSING			
<i>John D. Ray</i> ENGINEERING OFFICER		<i>W. A. ...</i> CHIEF ENGINEERING OFFICER	

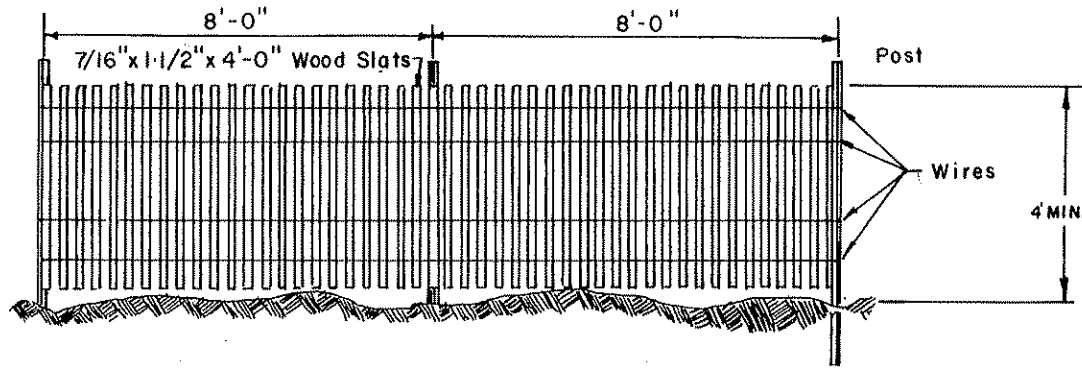

SLAT TYPE PORTABLE SNOW FENCE

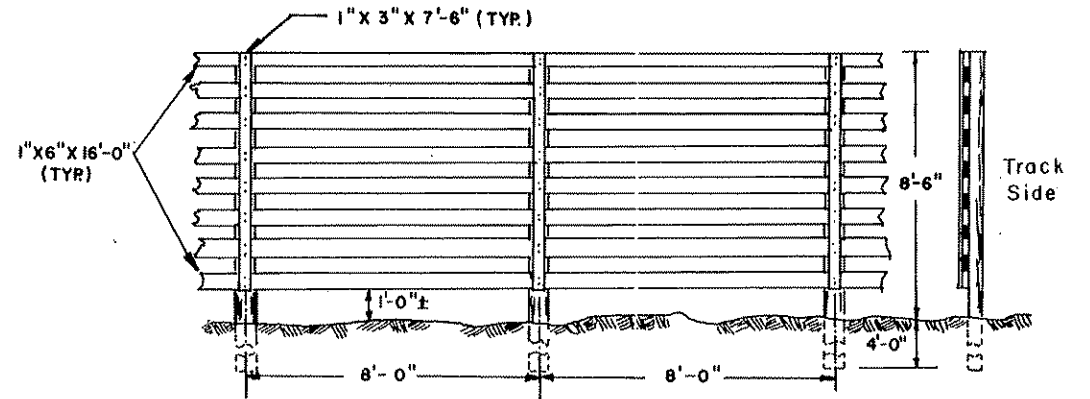

WOOD OPEN BOARD SNOW FENCE

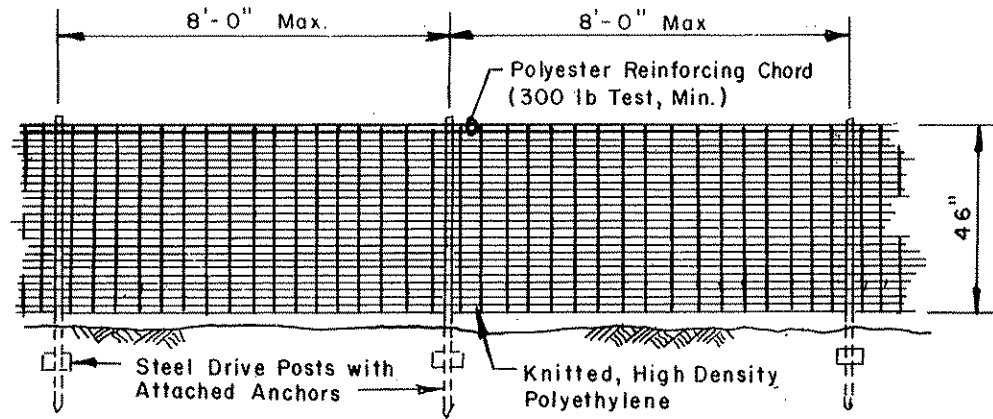

PORTABLE PLASTIC SNOW FENCE

NOTE

1. Posts and other materials used in the construction/erection of the snow fencing shall conform to the applicable standards of the AREA Manual, Part 6.

T	MASSACHUSETTS BAY TRANSPORTATION AUTHORITY	RAILROAD OPERATIONS	DWG. NO. 3200
		Oct. 28, 1992	① ISSUE NO.
SNOW FENCES			
<i>John D. Ray</i>		<i>W. A. ...</i>	
ENGINEERING OFFICER		CHIEF ENGINEERING OFFICER	

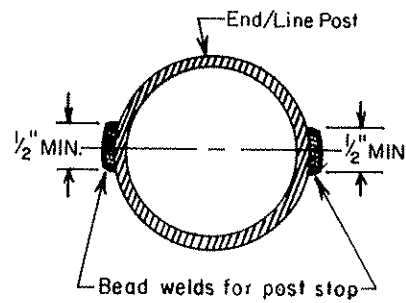

SECTION A-A

NOTE: Upon completion of bead welds, wire brush surface, extending into the undamaged galvanized coating. Apply Zinc-Rich paint in accordance with ASTM-A 780. Dry Film thickness of applied paint shall not be less than galvanized coating thickness required by ASTM-A 123.

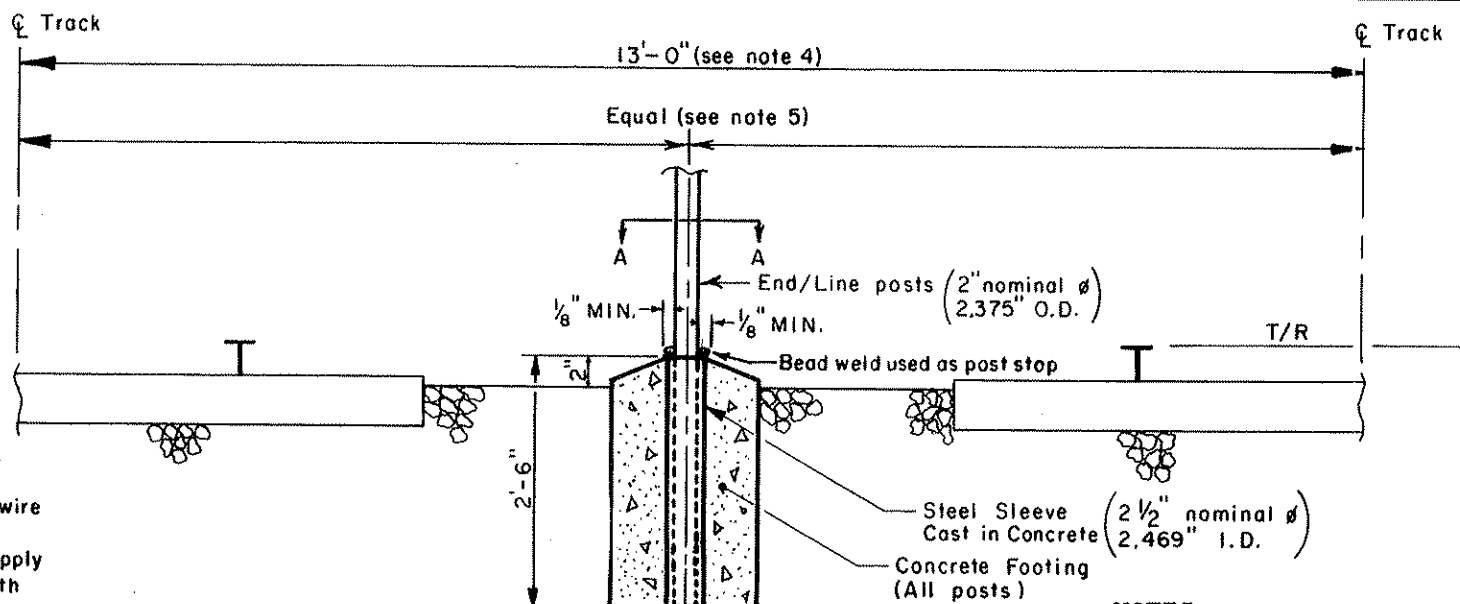

No part of Intertrack Fences shall be more than 4'-0" above top of rail.

Ascertain location and depth of any pipes and conduits prior to installation of fence

Leave Sleeve Open to the Bottom to Allow Water to Drain out

NOTES:

1. Intertrack Fences shall be used at double track stations with side platforms to control pedestrians crossing only at designated locations.
2. Where possible, fences should extend 100 feet beyond the end of the platform(s).
3. Fences must be installed to allow for their expedient removal for track maintenance and subsequent reinstallation with minimum hardware replacement.
4. 13'-0" is standard tangent track spacing. Fence shall not be installed when track centers are less than 12'-5" (Tangent).
5. Fence shall be installed equidistant from the two tracks but in no case shall the distance from centerline of track to any part of the fence be less than 6'-0" (Tangent Track).
6. To discourage vaulting over the fence, do not use top rails (except at end panels).
7. Details of Fence Fabric, Posts and Hardware as per Drawing 3206.

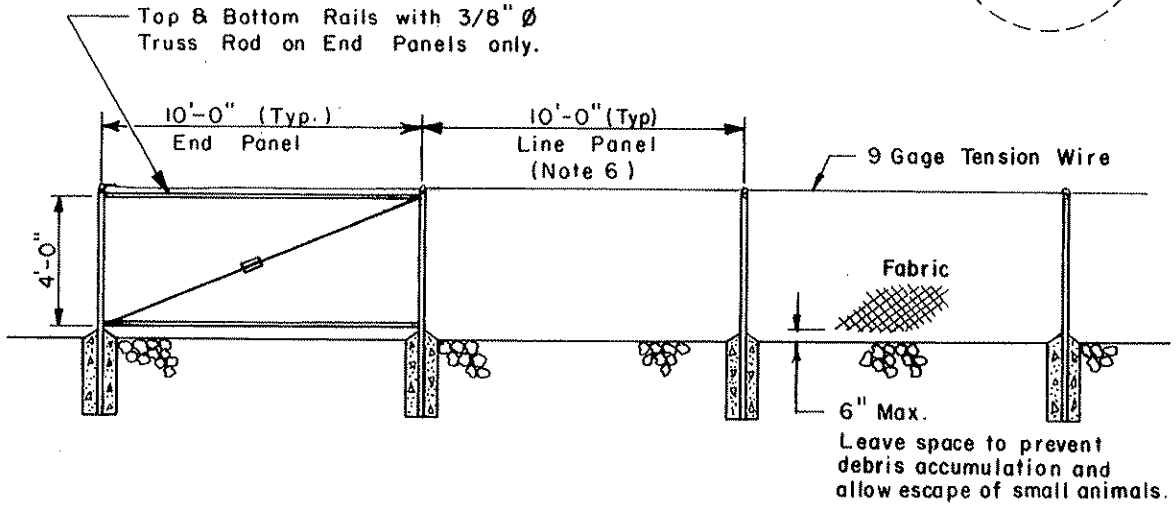

T MASSACHUSETTS BAY TRANSPORTATION AUTHORITY	RAILROAD OPERATIONS	DWG. NO. 3204	1 ISSUE NO.
		Oct. 28, 1992	
INTERTRACK FENCE			
John D. Ray ENGINEERING OFFICER		[Signature] CHIEF ENGINEERING OFFICER	

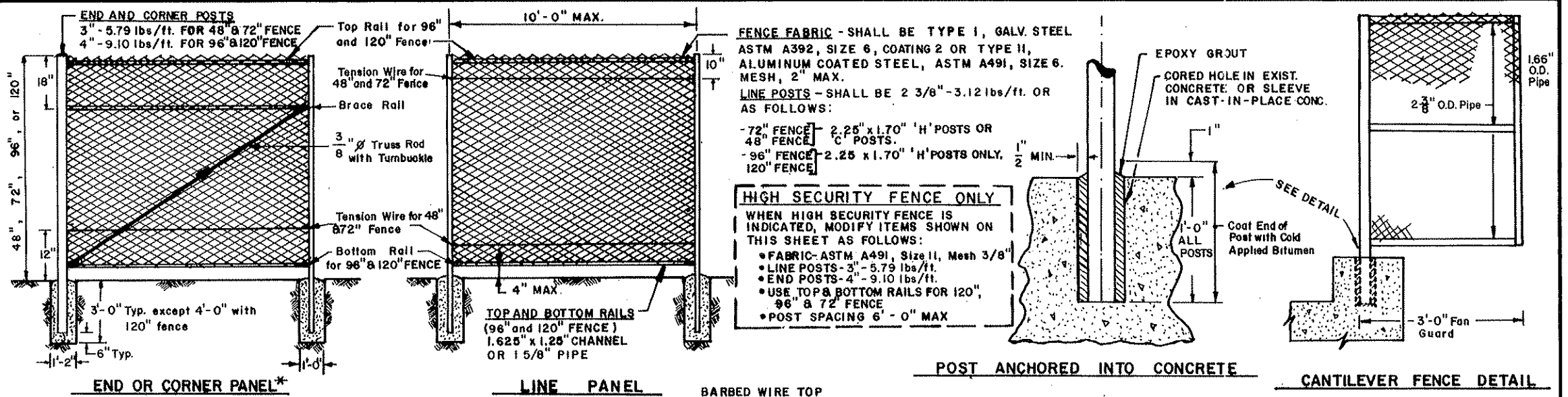

END OR CORNER PANEL*
 *BRACE PANEL TO INCLUDE AN ADDITIONAL PANEL BRACED AS SHOWN EXCEPT TRUSS ROD IN OPPOSITE DIRECTION.

LINE PANEL

BARBED WIRE TOP
 USE ON FENCE AND GATES WHEN INDICATED. SHALL BE THREE STRANDS OF BARBED WIRE SUPPORTED ON EXTENSION ARMS LOCATED ON ALL POSTS.

18" - 24" NO TRESPASSING SIGNS AS PER STANDARD PLAN NO. 3352 (TWO PER POST)

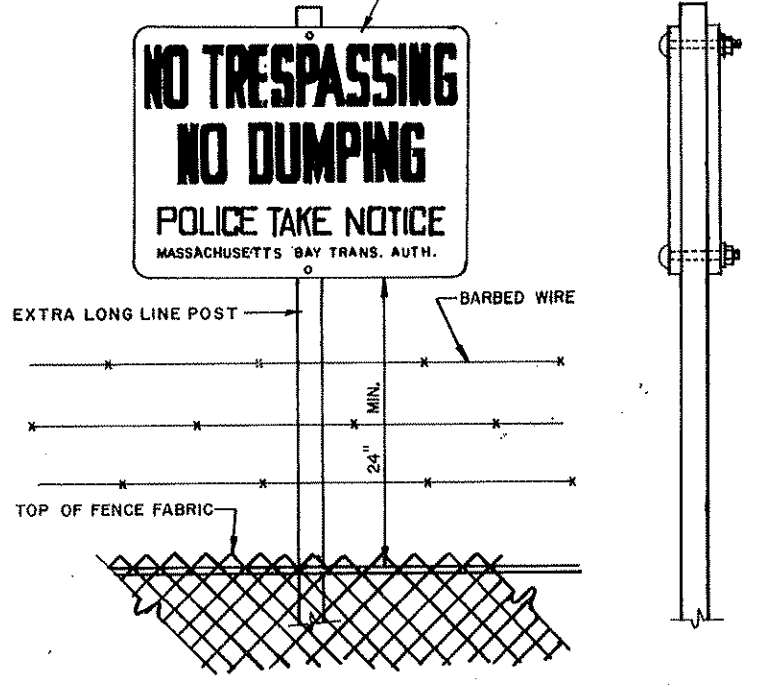

SIGN MOUNTING DETAIL

SIGN INSTALLATION NOTES

- 1. NO TRESPASSING SIGNS TO BE INSTALLED ON BOTH SIDES OF POSTS, FASTEN WITH 2 - 3/8" HIGH STRENGTH BOLTS, NUTS AND WASHERS. END OF BOLTS TO BE TACK WELDED TO PREVENT EASY REMOVAL OF SIGNS.
- 2. SIGNS TO BE INSTALLED AT 200' MAX INTERVALS, ALL LOCATIONS WHERE FENCE ANGLE CHANGES MORE THAN 30° AND ON ALL GATES. (FOR GATE INSTALLATION, SEE PLAN NO. 3208.)

GENERAL NOTES

- 1. FOR HIGH SECURITY FENCE, SEE THE DASHED BOX TOP CENTER OF DRAWING.
- 2. FOR INTERMEDIATE BRACING PANEL, SEE "END OR CORNER PANEL".
- 3. ALL PIPE DIMENSIONS ARE OUTSIDE DIAMETER.
- 4. ALL POSTS AND HARDWARE SHALL BE HOT-DIPPED GALVANIZED STEEL.

MASSACHUSETTS BAY TRANSPORTATION AUTHORITY	RAILROAD OPERATIONS	DWG. NO. 3206
		Oct. 28, 1992 2 <small>ISSUE DATE ISSUE NO.</small>
CHAIN LINK FENCING 48", 72", 96", 120" and "HIGH SECURITY" TYPE		
<i>John D. Ray</i> ENGINEERING OFFICER		<i>W. J. ...</i> CHIEF ENGINEERING OFFICER

When barbed wire fence is indicated, the barbed wire shall also be placed on the gates

All gates shall have a NO TRESPASSING sign mounted on the outside of the fence fabric as shown below.

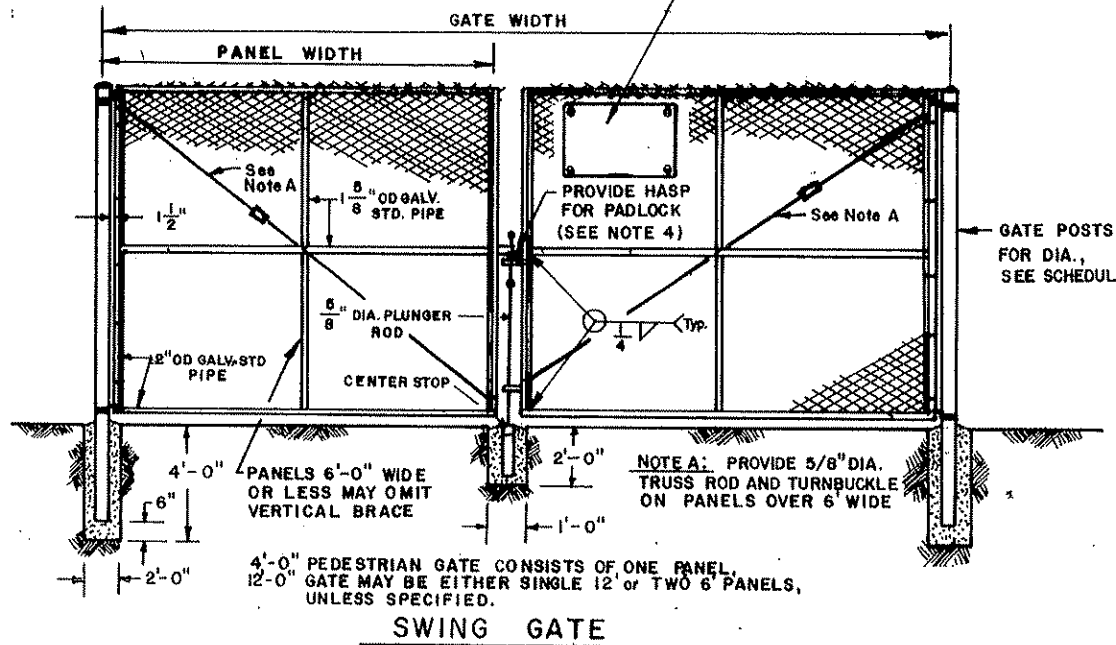

GATE POST SCHEDULE

HEIGHT OF FENCE	GATE WIDTH	GATE POSTS	
		O. D.	WEIGHT
96"	4'-0"	4"	9.10 lbs./ft.
	12'-0"	6 5/8"	18.97 "
	20'-0"	6 5/8"	18.97 "
120"	24'-0"	6 5/8"	18.97 "
	30'-0"	8 5/8"	28.55 "
	48"	4'-0"	3"
72"	12'-0"	4"	9.10 "
	20'-0"	6 5/8"	18.97 "
	24'-0"	6 5/8"	18.97 "
	30'-0"	6 5/8"	18.97 "

NOTES:

1. For fabric, see drawing NO. 3206
2. All hinges and hardware to be the heaviest available and hot dip galvanized.
3. Sliding or cantilever type gates may also be used. Details must be submitted for approval.
4. Hasp shall have a hole diameter & overall size to accept the MBTA's standard R.O.W. lock.

Gate panels over 15'-0" must have additional bracing than that shown

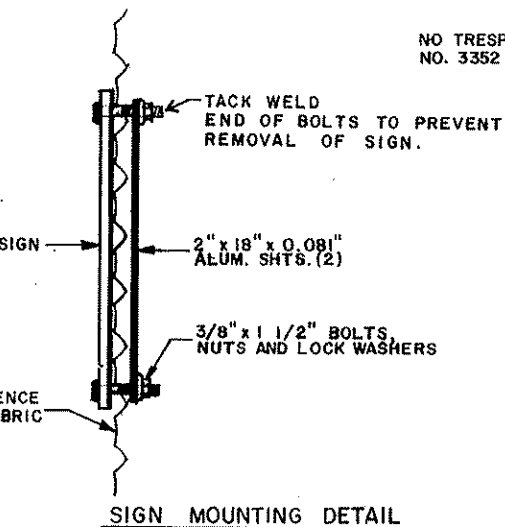

NO TRESPASSING sign as per STD PLAN NO. 3352



2" x 18" x 0.081 ALUM. SHEETS BEHIND SIGN AND FABRIC FOR MOUNTING.

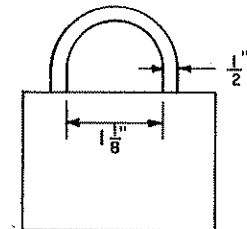

STANDARD MBTA R.O.W. LOCK

MASSACHUSETTS BAY TRANSPORTATION AUTHORITY	RAILROAD OPERATIONS	DWG. NO. 3208
		Oct. 28, 1992
CHAIN LINK FENCE GATES		ISSUE NO. 1
John D. Ray ENGINEERING OFFICER		 CHIEF ENGINEERING OFFICER

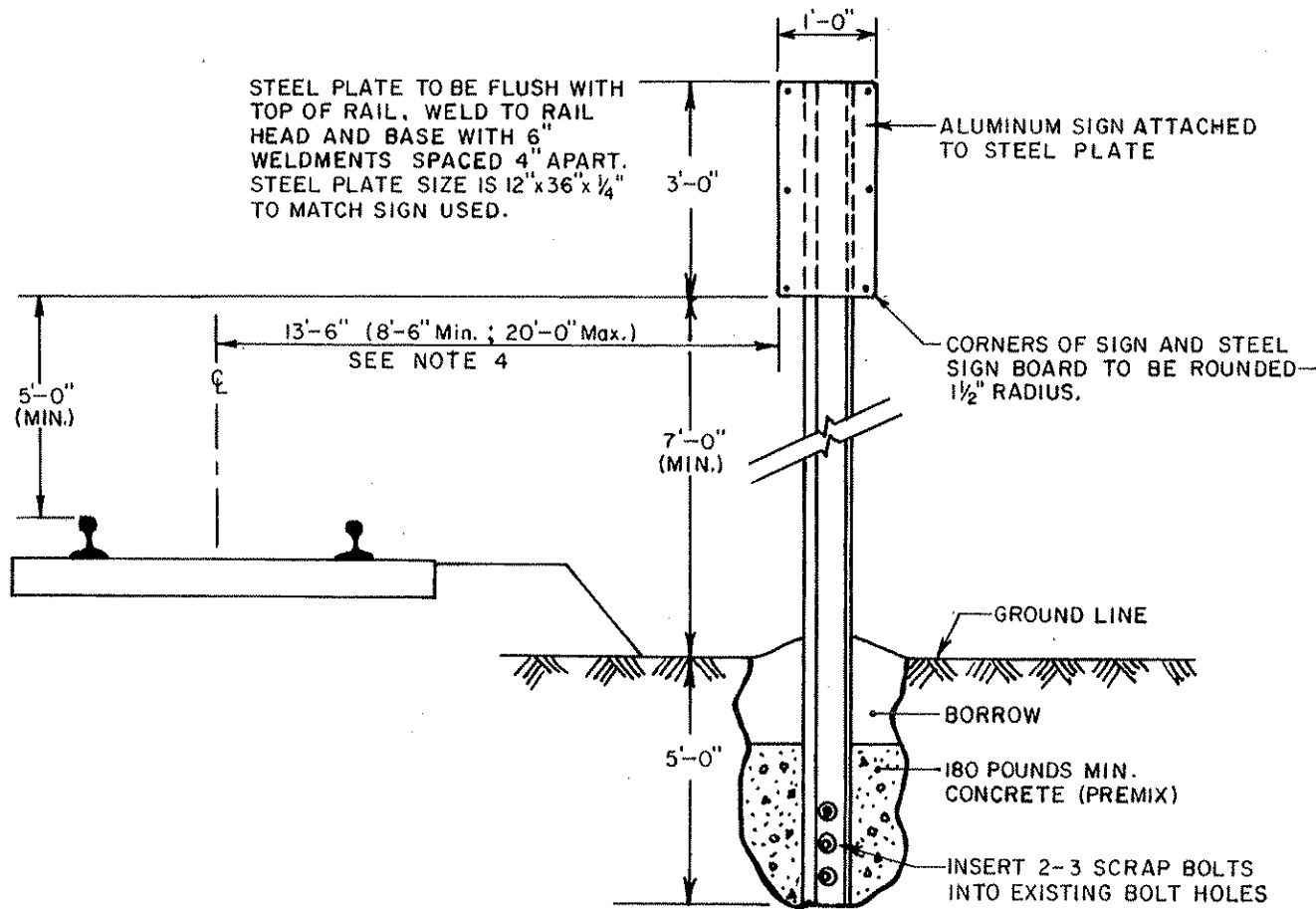

SIGN POST - FRONT VIEW

Not to Scale

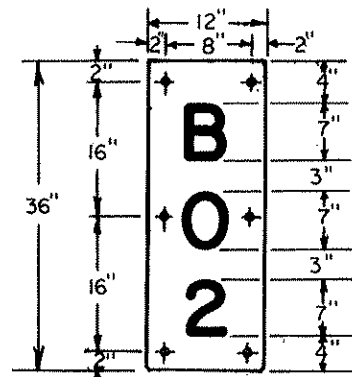

SIGN - FRONT VIEW

Not to Scale

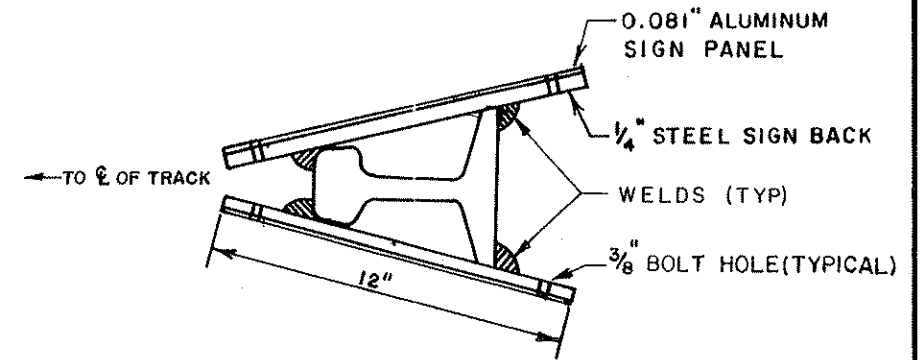

SIGN - TOP VIEW

Not to Scale

NOTES:

1. Posts are to be made from scrap rail, not less than 112 LB section, free from bends, kinks or visible damage. Length of posts shall be as required to place sign boards at the indicated dimensions and will be 15 feet long, minimum.
2. Two sign backs per post shall be 12"x36", 1/4" thick steel. Remove edging burrs, sharp edges, and corners.
3. Sign boards and rail posts shall be carefully cleaned with a solvent to remove all dirt and grease. A coat of primer suitable for use on metal shall be applied to all surfaces, and two finish coats of durable white enamel suitable for outdoor use over metal shall be applied with 24 hours minimum drying time between coats.
4. 13'-6" dimension, sign to centerline of track, may be altered where conditions such as steep embankment slope prohibit placement. In no case shall sign be closer than 8'-6" to centerline of track, nor further than 20'-0".
5. Sign to be 12"x36"x.081" Aluminum Alloy 6081-T6 with 6 - 3/8" holes as shown.
6. Mount sign to 1/4" steel plate with 4 - 5/16" bolts 1" long, 4 flat washers, 4 lock washers and 4 nuts all cadmium plated. Steel plate shall be sized and drilled to match sign.
7. Background to be white reflectorized, FSL-S-300 A type, class 1 or 2, reflectivity 1.
8. Mileage numerals and letters shall be 7" high Helvetica Medium style, black gloss silk screen letters MHD materials spec. M7.04.12.

T	MASSACHUSETTS BAY TRANSPORTATION AUTHORITY	RAILROAD OPERATIONS	DWG. NO. 3302	①
			ISSUE DATE Oct. 28, 1992	

MILE POSTS

John D. Ray
ENGINEERING OFFICER

W. A. ...
CHIEF ENGINEERING OFFICER

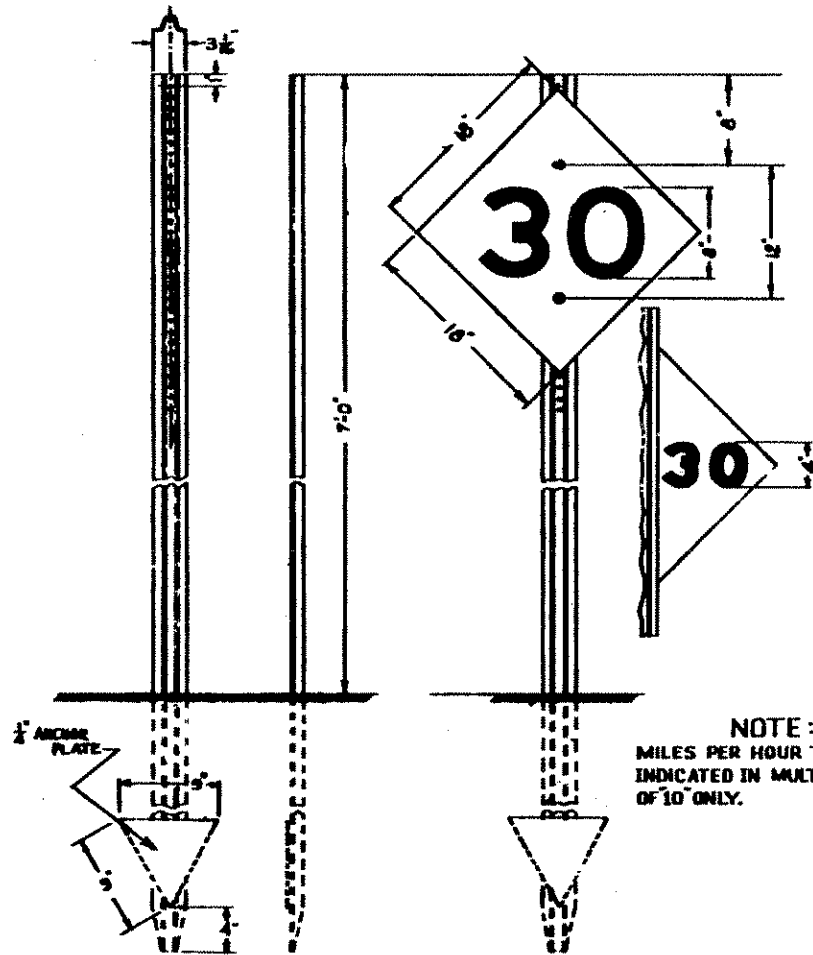

SIGN POST
 U-SECTION POST HEAVY TYPE OF 3/4" ROLLED OPEN HEARTH STEEL. 30-3/8" HOLES ON 1" CENTERS. LENGTHS OF POSTS TO BE DETERMINED IN FIELD. BAKED ENAMEL FINISH (BLACK)

SPEED RESTRICTION SIGN
 USE A 16"x16"x.001" ALUMINUM ALLOY 6061-T6 No. 2271 YELLOW SCOTCHLITE, 605 BLACK SCOTCHCAL. 7" SERIES "O" NUMBERS. PUNCH 2-3/16" HOLES AS SHOWN FOR 2-3/16" BOLTS 2" LONG AND 4 WASHERS CADMIUM PLATED. LOCATION - POST 11" FROM CENTER LINE OF TRACK WHEN POSSIBLE. LOCATION - NOT LESS THAN ONE-HALF MILE IN ADVANCE OF THE POINT AT WHICH THE SPEED RESTRICTION BEGINS.

NOTE:
 MILES PER HOUR TO BE INDICATED IN MULTIPLES OF 10 ONLY.

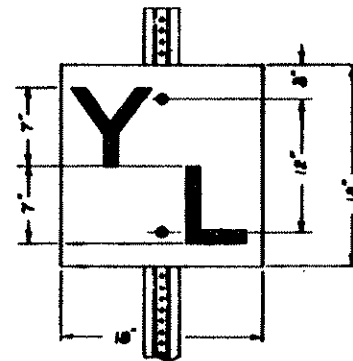

YARD LIMIT SIGN

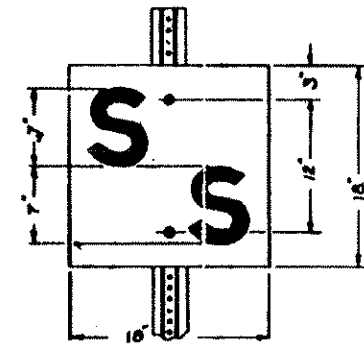

SPRING SWITCH SIGN

USE 16"x16"x.001" ALUMINUM ALLOY 6061-T6 No. 2271 YELLOW SCOTCHLITE AND 605 BLACK SCOTCHCAL. 7" SERIES "O" LETTERS. PUNCH 2-3/16" HOLES AS SHOWN FOR 2-3/16" BOLTS 2" LONG AND 4 WASHERS CADMIUM PLATED. 2 SIGNS REQUIRED ONE ON EACH SIDE OF POST. LOCATION 11"-3" FROM CENTER LINE OF TRACK. SPRING SWITCH SIGN OPPOSITE SW. POINT LEFT SIDE.

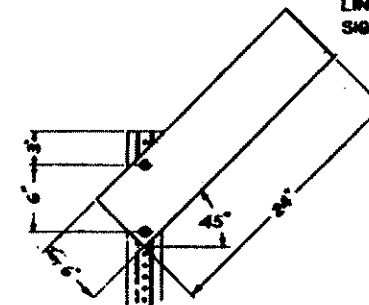

SNOW FLANGER SIGN
 USE 8"x24"x.001" ALUMINUM ALLOY 6061-T6, 2271 YELLOW SCOTCHLITE. PUNCH 2-3/16" HOLES AS SHOWN FOR 2-3/16" BOLTS 2" LONG AND 4 WASHERS CADMIUM PLATED. LOCATION 10'-0" FROM CENTER LINE OF TRACK, 50'-0" FROM OBSTRUCTION ON ENGINEERS SIDE WITH ANGLE TO THE RIGHT.

T	MASSACHUSETTS BAY TRANSPORTATION AUTHORITY	RAILROAD OPERATIONS	DWG. NO. 3304
			Nov. 17, 1986 ISSUE DATE

**SPEED RESTRICTIONS, YARD
 LIMIT & FLANGER SIGNS**

Daniel Brennan
 ENGINEERING OFFICER

W.A. McNeill
 CHIEF ENGINEERING OFFICER

REQUIREMENTS

FOR ONE SINGLE-TRACK LOCATION (2) REDUCE-SPEED BOARDS - (2) SLOW BOARDS - " (2) RESUME-SPEED BOARDS - " (2) PLATES 10"x18" (10-20) - "	(2) PLATES 10"x18" (30-40) (6) U-SECTION POSTS, 9'-6" LONG (26) 2" BOLTS	FOR ONE DOUBLE-TRACK LOCATION (2) REDUCE-SPEED BOARDS (2) SLOW BOARDS - " (2) RESUME-SPEED BOARDS - " (2) PLATES 10"x18" (10-20) - " (2) PLATES 10"x18" (30-40) - " (6) U-SECTION POSTS 9'-6" LONG (26) 2" BOLTS	(2) REDUCE-SPEED BOARDS (2) SLOW BOARDS - " (2) RESUME-SPEED BOARDS - " (2) PLATES 7"x12" (10-20) * (2) PLATES 7"x12" (30-40) * (4) U-SECTION POSTS 4'-11" LONG (20) 2" BOLTS
---	--	--	---

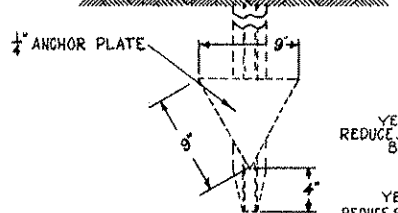
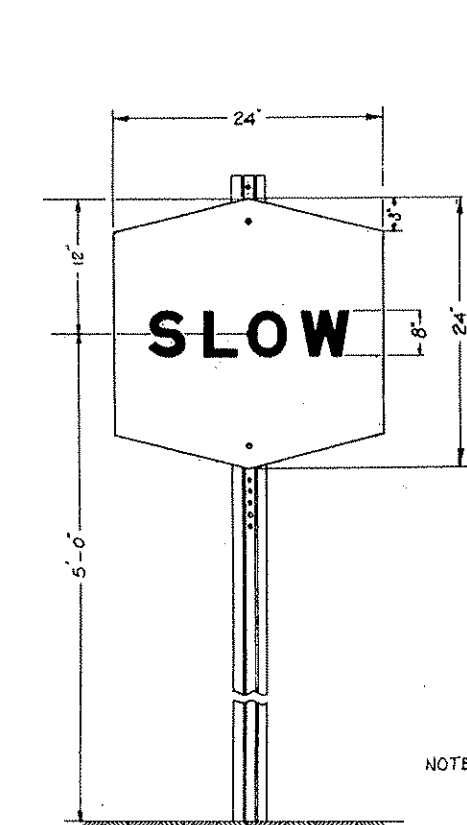

SLOW BOARD
 USE A 24"x24"x.081" ALUMINUM ALLOY 6061-T6, No. 2271 YELLOW SCOTCHLITE, 8" SERIES "D" LETTERS 605 BLACK SCOTCHCAL. ON REVERSE SIDE. USE 485 BLACK SCOTCHCAL.

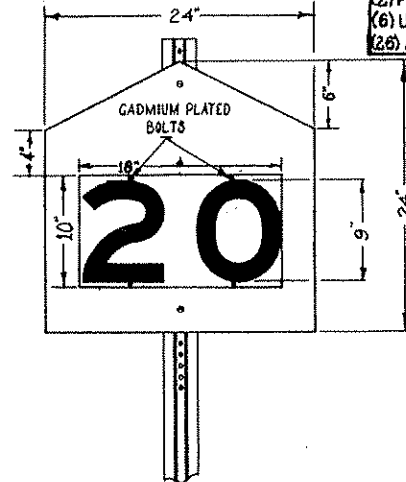

REDUCE SPEED BOARD
 USE A 24"x24"x.081" ALUMINUM ALLOY 6061-T6, No. 2271 YELLOW SCOTCHLITE ON REVERSE SIDE USE 485 BLACK SCOTCHCAL

TWO ATTACHABLE (10"x18" ALUMINUM PLATES) WITH 9" SERIES "D" NUMBERS (605 BLACK SCOTCHCAL) AND NO. 2271 YELLOW SCOTCHLITE ON EACH SIDE AS FOLLOWS: (10-20), (30-40) (ATTACH PLATES WITH CADMIUM PLATED BOLTS AND WASHERS)

NOTE: PUNCH 3/8" HOLES AS SHOWN ON EACH PLATE FOR 3/8" BOLTS 2" LONG WITH CADMIUM PLATED WASHERS

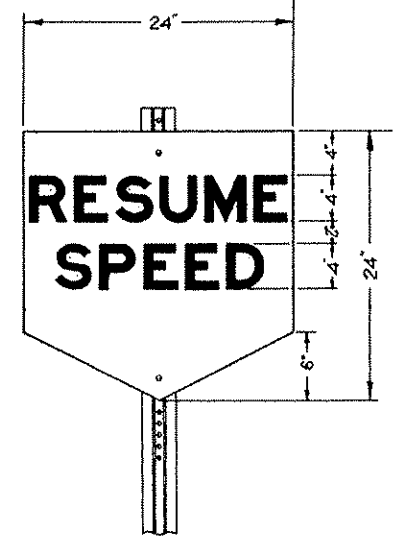

RESUME SPEED BOARD
 USE A 24"x24"x.081" ALUMINUM ALLOY 6061-T6, No. 2277 GREEN SCOTCHLITE, 4" SERIES "D" LETTERS 605 BLACK SCOTCHCAL, ON REVERSE SIDE USE 485 BLACK SCOTCHCAL.

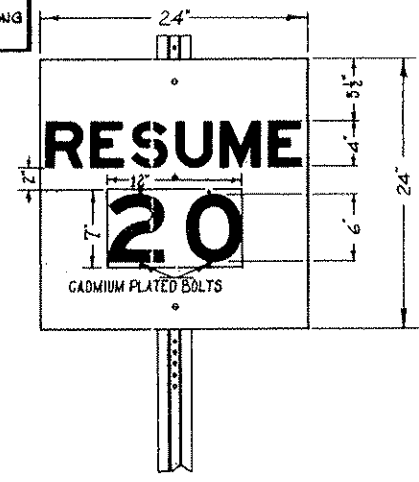

INTERMEDIATE RESUME SPEED BOARD
 USE A 24"x24"x.081" ALUMINUM ALLOY 6061-T6, No. 2271 YELLOW SCOTCHLITE, 4" SERIES "D" LETTERS 605 BLACK SCOTCHCAL ON REVERSE SIDE USE 485 BLACK SCOTCHCAL. TWO ATTACHABLE (7"x12" ALUMINUM PLATES) WITH 6" SERIES "D" NUMBERS (605 BLACK SCOTCHCAL) AND NO. 2271 YELLOW SCOTCHLITE ON EACH SIDE AS FOLLOWS: (10-20), (30-40) (ATTACH PLATES WITH CADMIUM PLATED BOLTS AND WASHERS)

(TO BE USED WHEN A SECONDARY RESTRICTION IS SET UP WITHIN THE LIMITS OF RESTRICTION)
 LOCATION: 100 FT. BEYOND THE POINT TO BE PROTECTED AND UPON THE RIGHT OF AND ADJOINING TRACK TO WHICH IT REFERS.

NOTE A THE DISTANCES BETWEEN SIGNS IS VARIABLE AND IS A FUNCTION OF TRACK SPEED. SEE DRAWING 3307.

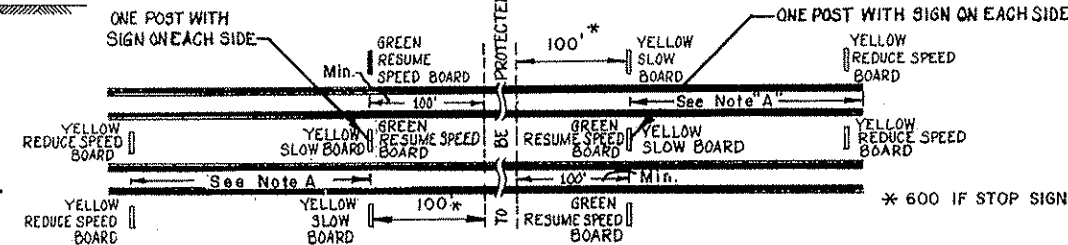

LOCATION OF TEMPORARY SLOW BOARDS — DOUBLE TRACK

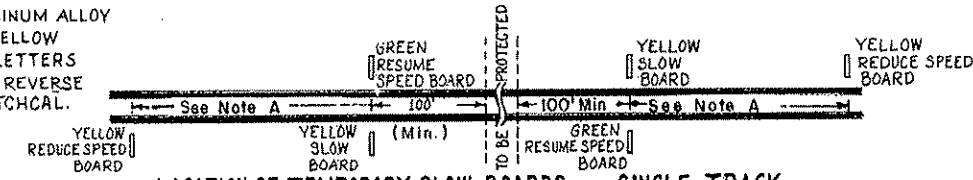

LOCATION OF TEMPORARY SLOW BOARDS — SINGLE TRACK

	MASSACHUSETTS BAY TRANSPORTATION AUTHORITY	RAILROAD OPERATIONS	DWG. NO. 3306
			Oct. 28, 1992 2 ISSUE DATE ISSUE NO.
TEMPORARY SLOW BOARDS			
ENGINEERING OFFICER		CHIEF ENGINEERING OFFICER	





Speed - MPH Reduced		Distance Between Signs - FEET (Level or Ascending Grade) *	
From	To	Passenger	Freight
80	70	1300	
"	60	2300	
"	50	3200	
"	40	4000	
"	30	4500	
"	20	5000	
"	10	5200	
"	STOP	5700	
70	60	1100	
"	50	2000	
"	40	2700	
"	30	3300	
"	20	3700	
"	10	4000	
"	STOP	4500	
60	50	1000	
"	40	1700	
"	30	2300	
"	20	2700	
"	10	3000	
"	STOP	3500	
50	40	800	2700
"	30	1400	4700
"	20	1800	6200
"	10	2200	7100
"	STOP	2700	7600

Speed - MPH Reduced		Distance Between Signs - FEET (Level or Ascending Grade) *	
From	To	Passenger	Freight
40	30	600	2100
"	20	1100	3500
"	10	1500	4500
"	STOP	2000	5000
30	20	500	1500
"	10	900	2400
"	STOP	1400	2900
20	10	400	900
"	STOP	900	1400
10	STOP	500	700

* For descending grades in percent, increase distances above as follows.

Level to 0.10 % - NONE	0.93% to 1.14% - 40%	1.65% to 1.78% - 80%
0.11% to 0.36% - 10%	1.15% to 1.33% - 50%	1.79% to 1.90% - 90%
0.37% to 0.66% - 20%	1.34% to 1.50% - 60%	1.91% to 2.00% - 100%
0.67% to 0.92% - 30%	1.51% to 1.64% - 70%	2.01% to 2.10% - 110%

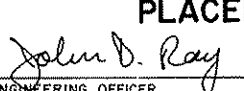
NOTE: See Drawing NO. 3306 for sign detail and placement.

 MASSACHUSETTS BAY TRANSPORTATION AUTHORITY	RAILROAD OPERATIONS	DWG. NO. 3307	
		Oct. 28, 1992 ISSUE DATE	
TABLE OF SLOW BOARD PLACEMENT DISTANCES			
 ENGINEERING OFFICER		 CHIEF ENGINEERING OFFICER	

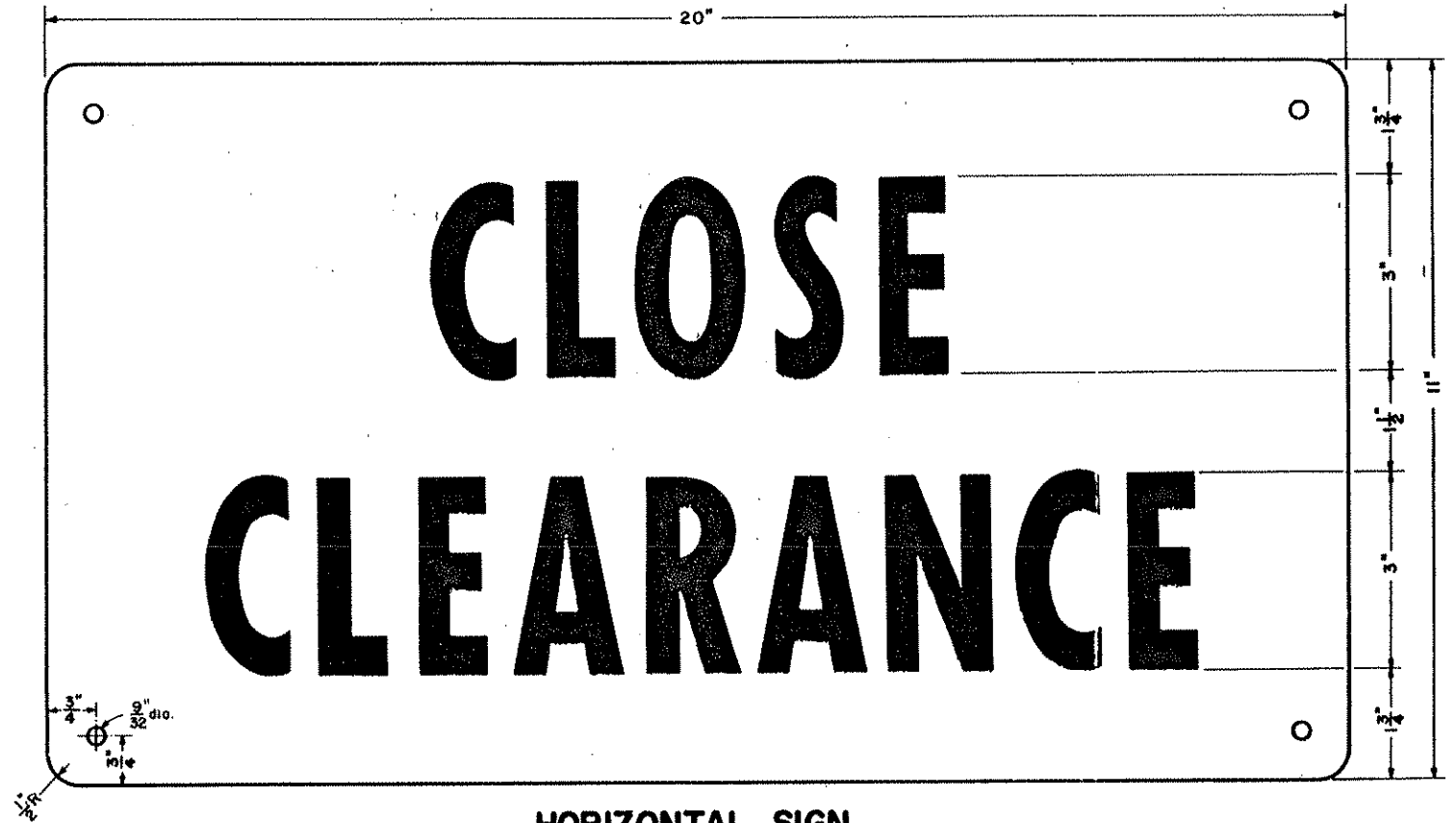
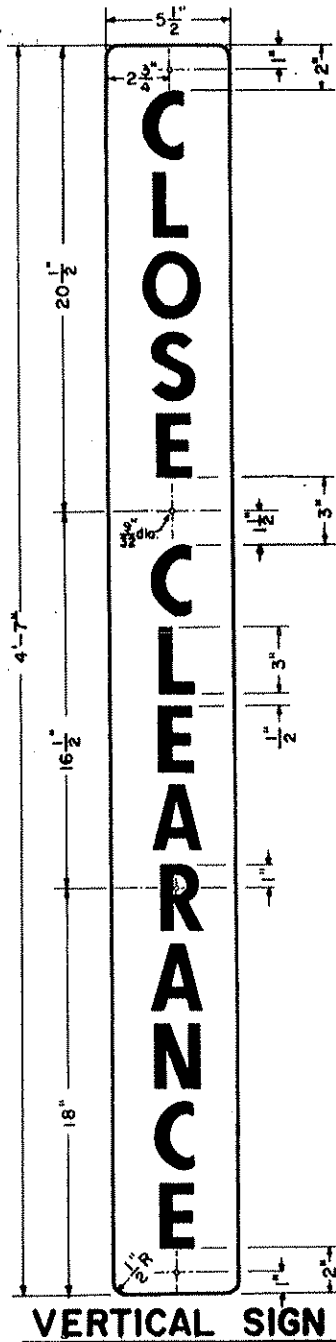

NOTES

- 1 - The sign plate shall be 6061-T6 aluminum sheeting .081" thick, with one side covered with No.2870 Silver Scotchlite and No.605 Black Scotchoal letters.
- 2 - "Close Clearance" signs shall be displayed where objects do not provide for full clearance as per Plans 1012 to 1018. The signs shall be attached to the side of a building or other flat surface and shall be held away from the surface about 1" with furring strips or spools, to allow for ventilation. No.14 aluminum round head wood screws or 1/4" dia. aluminum bolts shall be used to attach the signs. Aluminum washers shall be used under heads of bolts or screws.
- 3 - Lettering to be MBTA Standard Helvetica for the vertical sign and in the condensed form for the horizontal sign.
- 4 - Signs to be furnished with attachment hardware.

MASSACHUSETTS BAY TRANSPORTATION AUTHORITY	RAILROAD OPERATIONS	DWG. NO. 3312 Nov. 17, 1986 <small>ISSUE DATE</small>	(1) <small>ISSUE NO.</small>
	CLOSE CLEARANCE SIGNS		
<i>Daniel Brennan</i> <small>ENGINEERING OFFICER</small>		<i>W. A. Mendenhall</i> <small>CHIEF ENGINEERING OFFICER</small>	

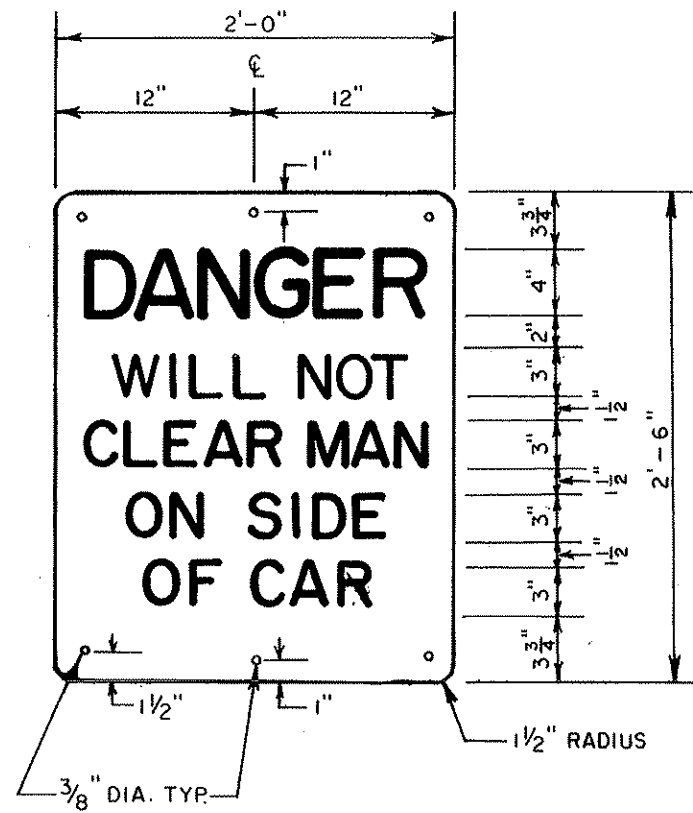

Helvetica Medium
black letters on
yellow reflective
field, center.

CLEARANCE WARNING SIGN

- Signs to be 0.081" thick aluminum alloy sheet, ASTM B 209.
- Black gloss silk letters MHD materials spec. M7.04.12.

NOTES:

1. Free standing signs shall be mounted on steel "U" shaped posts. Signs attached to structures shall be attached using threaded inserts.
2. All signs shall have six holes drilled to allow mounting on either posts or structures.

T	MASSACHUSETTS BAY TRANSPORTATION AUTHORITY	RAILROAD OPERATIONS	DWG. NO. 3314
			Oct. 28, 1992 ISSUE DATE
CLEARANCE WARNING SIGN			
<i>John D. Ray</i>		<i>W. A. ...</i>	
ENGINEERING OFFICER		CHIEF ENGINEERING OFFICER	

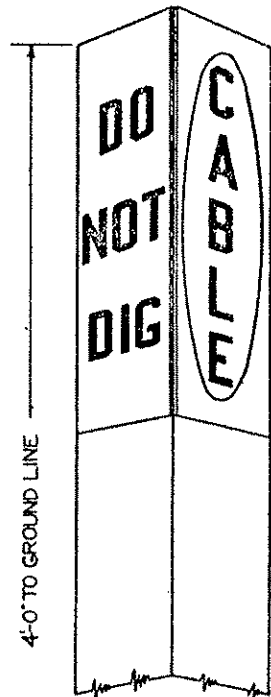
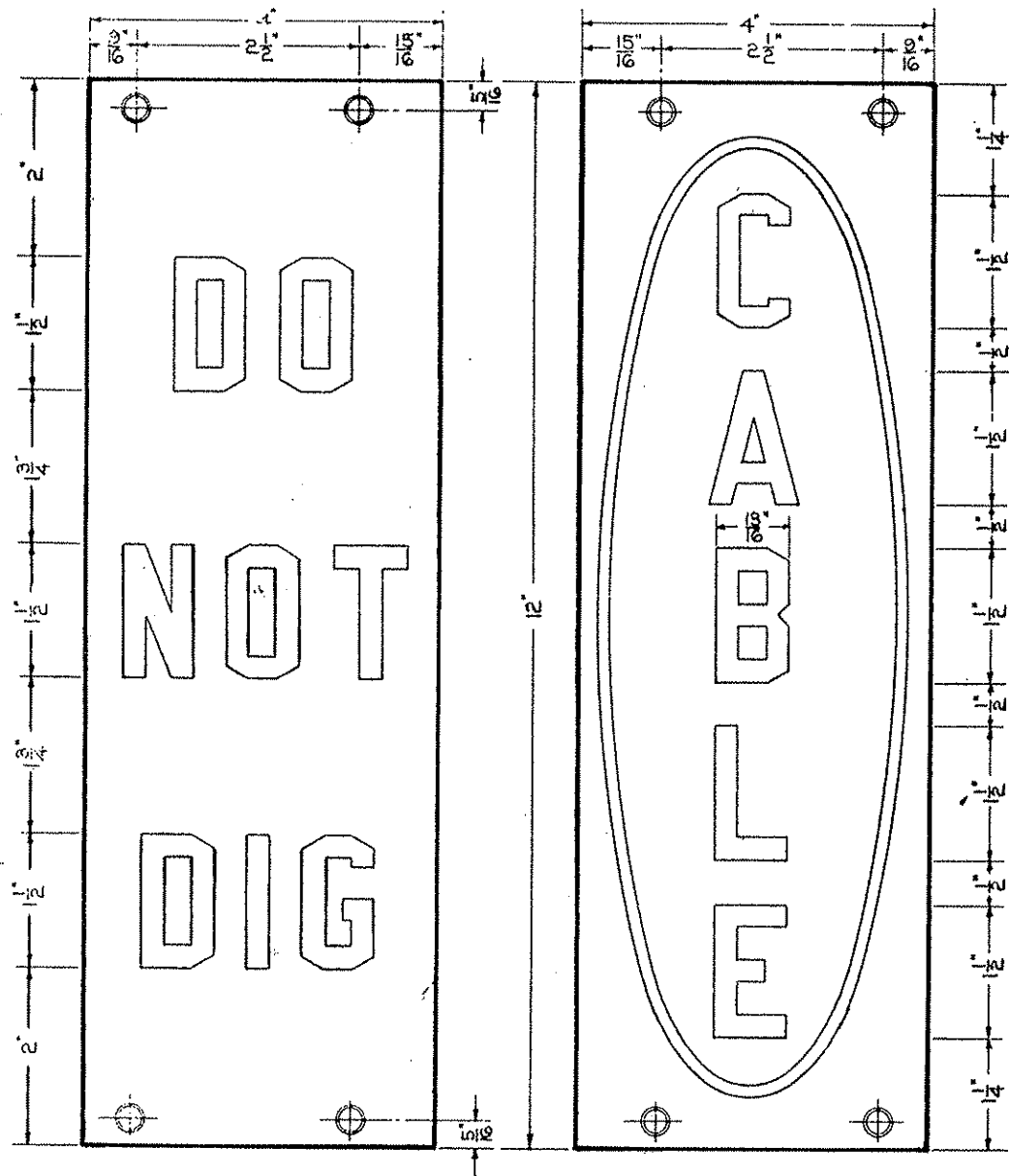

LOCATION OF SIGNS ON ANGLE IRON POST

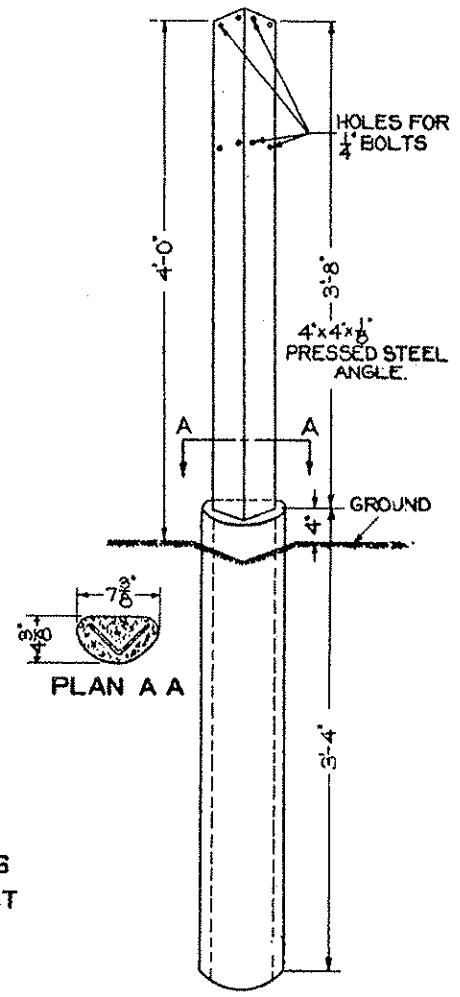

SIGN POST DETAIL

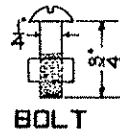

BOLT

NOTES

SIGNS TO BE MADE OF #18 GAGE STEEL AND HAVE PORCELAIN ENAMEL FINISH.
 COLORS- WORDS "DO NOT DIG" BLACK. BALANCE OF SIGN WHITE. WORD "CABLE" BLACK ON YELLOW OVAL. LINE AROUND OVAL BLACK. BALANCE OF SIGN WHITE.
 POST- 4x4x1/8 PRESSED STEEL ANGLE IRON, GALVANIZED & SET IN CONCRETE FOOTING.
 BOLTS-SIGN BOLTS 1/4 x 3/4 AS SHOWN, TO BE BRONZE OR BRASS.

	MASSACHUSETTS BAY TRANSPORTATION AUTHORITY	RAILROAD OPERATIONS	DWG. NO. 3344 Nov. 17, 1986 ISSUE DATE	1 ISSUE NO.
	DO NOT DIG- BURIED CABLES			
<i>Daniel Green</i> ENGINEERING OFFICER		<i>W. A. MacDonell</i> CHIEF ENGINEERING OFFICER		



NOTES:

1. Free standing signs not attached to fences to be mounted on steel "U" shaped posts.
2. Place signs on both sides of right of way facing back towards highway grade crossing, at end of station platforms and at any location where trespassing is a problem.
3. Place on ROW fences at intervals not exceeding 200' (see Dwg. No.3206) and on all gates (see Dwg. No.3208).
4. All signs shall have six holes drilled to allow mounting on either posts or fence fabric.

NO TRESPASSING SIGN

- Signs to be 0.081" thick aluminum alloy sheet - ASTM B 209
- White reflectorized background. FS L-S-300 A TYPE, Class 1 or 2, reflectivity 1
- Black gloss silk screen letters MHD materials spec. M7.04.12

	MASSACHUSETTS BAY TRANSPORTATION AUTHORITY	RAILROAD OPERATIONS	DWG. NO. 3352
			Oct. 28, 1992 ISSUE DATE
<p>NO TRESPASSING SIGN</p> <p><i>John D. Ray</i> <i>W. A. ...</i></p> <p>ENGINEERING OFFICER CHIEF ENGINEERING OFFICER</p>			

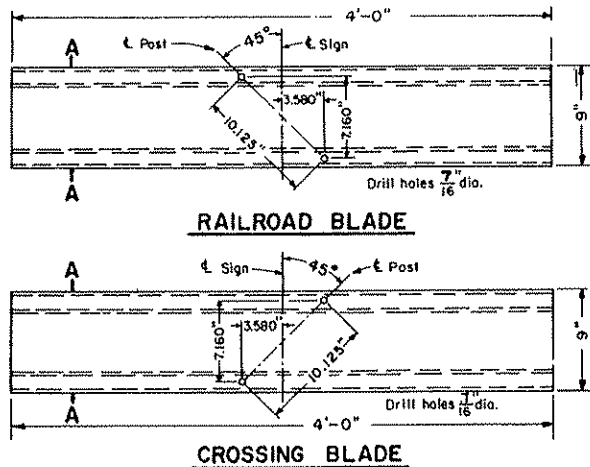
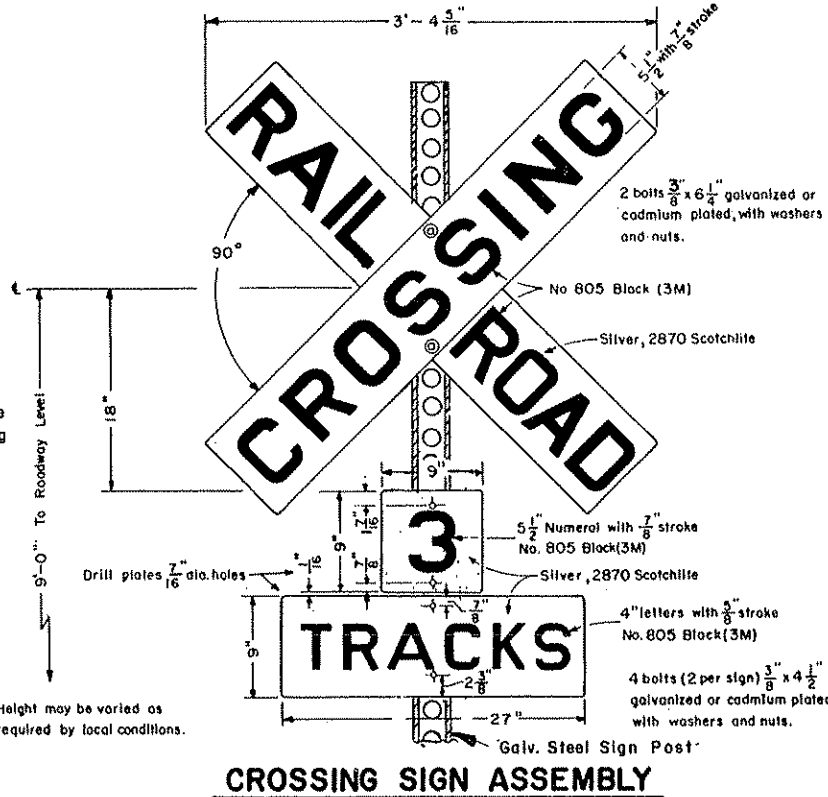
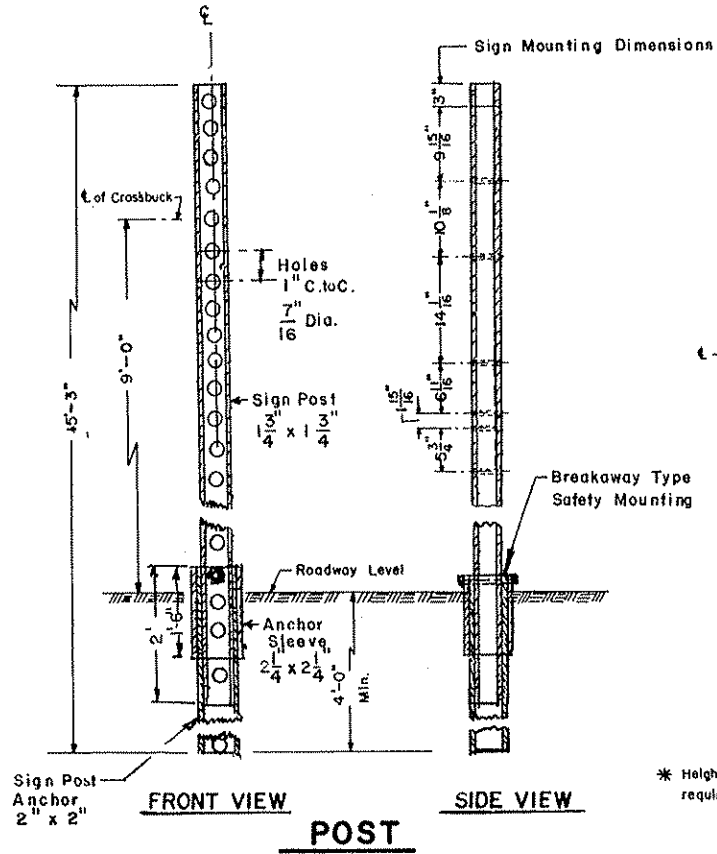

EXTRUDED ALUMINUM BLADES

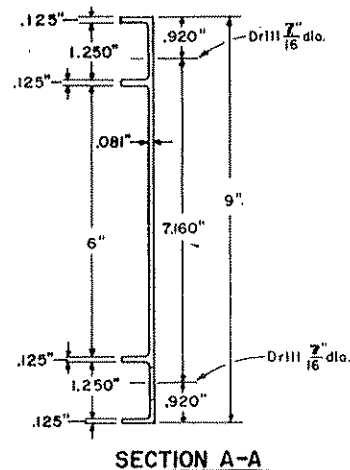

SECTION A-A

NOTES

Highway Crossing Sign for use where automatic signal protection is not required.

Location-The sign shall be erected on the right hand side of the roadway on each approach to the crossing. The center line of the post shall be placed not less than 10'-6" or more than 15'-0" from the center line of the track and 6 feet from the edge of the highway shoulder or 12 feet from the edge of the traveled way in rural areas and 2 feet from the face of the curb in urban areas will usually be attainable. Where unusual conditions demand, variations determined by good judgement should provide the best possible combination of view and safety clearances attainable. The height should be 9'-0" above the roadway level to the center of the crossbar, but may be varied to suit local conditions.

Crossbar-The blades shall be 6063-T6 extruded aluminum. The face of the blades shall be covered with No.2870 Silver, High Intensity Grade, Scotchlite sheeting with No.805 Black Ink (3M) letters, or equal.

Number of Tracks Sign-The sign to be used where there are two or more tracks. The number displayed on the sign shall be the total number of tracks crossed, including sidings. Normally, where the distance between tracks, measured along the highway, exceeds 100 feet, an additional crossing sign should be erected unless local conditions require otherwise. The sign shall be .081", 6061-T6 aluminum sheet. The face of the signs shall be covered with No. 2870 Silver, High Intensity Grade, Scotchlite sheeting with No.805 Black Ink(3M) letters, or equal.

Specifications - As per current issue of the Federal Highway Administration, Part VIII Traffic Control Systems for Railroad Grade Crossings." The letters and numerals as per current A.A.R. Signal Section Plans 1712, 1713 and 1714.

Ordering-Specify sign complete or individual crossbar, track sign or post, in addition the numeral for the track sign must be specified. Any modifications necessary to comply with legal requirements must be specified.

T	MASSACHUSETTS BAY TRANSPORTATION AUTHORITY	RAILROAD OPERATIONS	DWG. NO. 3388	① ISSUE NO.
			Nov. 17, 1986 ISSUE DATE	

**PUBLIC CROSSING
NO WARNING DEVICES**

Daniel Brain ENGINEERING OFFICER *WA [Signature]* CHIEF ENGINEERING OFFICER

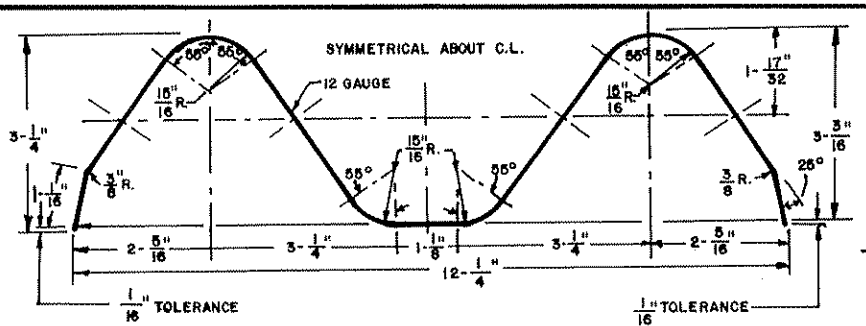

SECTION THROUGH RAIL AT SPLICE

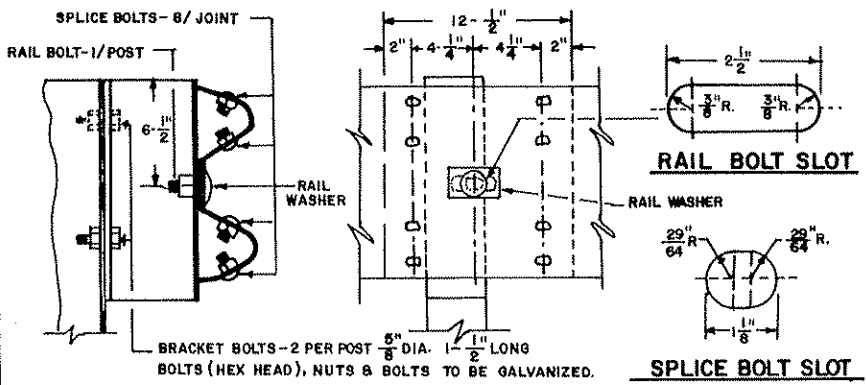

RAIL SPLICE

NOTES:

1. Spacing of Posts to be 6'-3" centerline of Post to centerline of Post.
2. Terminal Section shown for parking areas or low vehicular speed areas Only. See Mass. Dept. of Public Works Standards for End Treatment in Higher speed areas (Steel Beam Highway Guard Type S3).
3. Post and offset brackets to be fabricated from 6" X 4", 8-1/2 lbs. per linear foot, steel "H" sections.
4. Post and bracket holes to be 3/4" dia.
5. Back up plate to be used on posts where no splice occurs.
6. All metal parts to be galvanized steel.

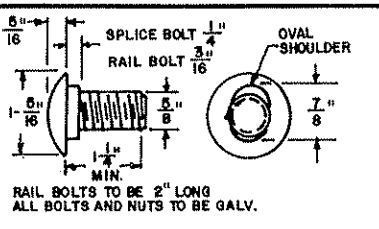

RAIL & SPLICE BOLTS & NUTS

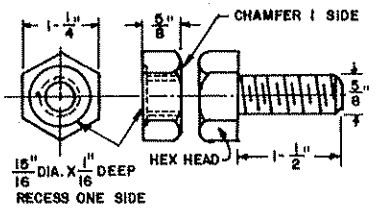

BRACKET BOLT

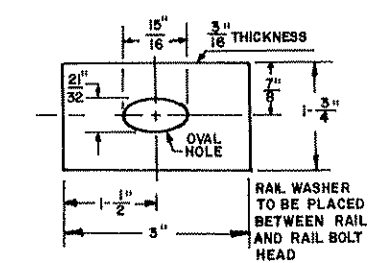

RAIL WASHER

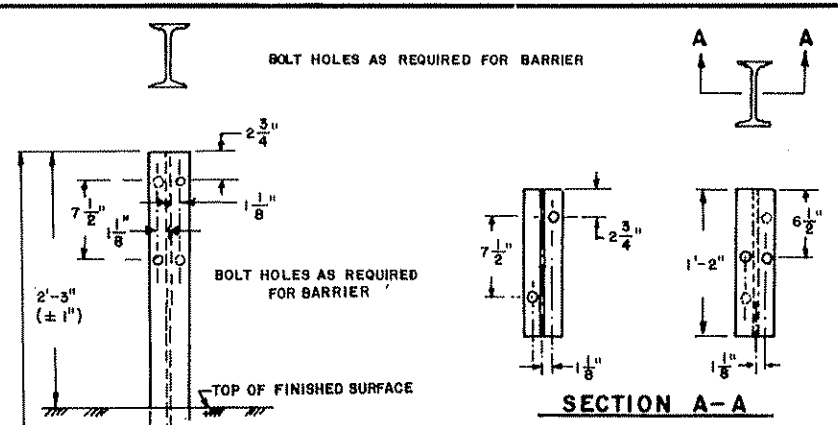

POST

SECTION A-A

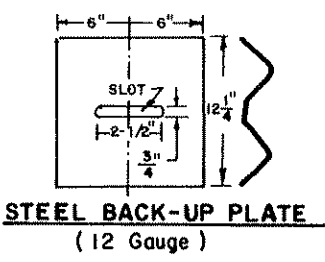

STEEL BACK-UP PLATE (12 Gauge)

OFFSET BRACKET

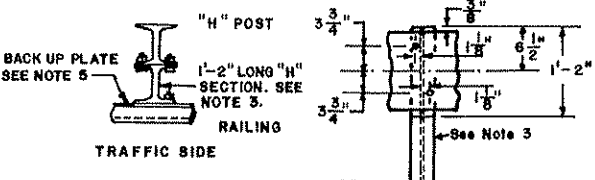

TYPICAL DETAILS

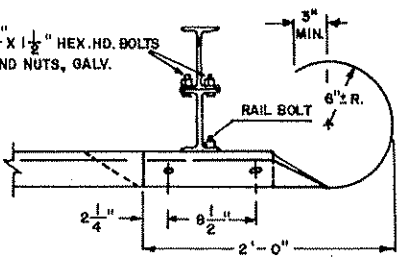

TERMINAL SECTION (SEE NOTE 2)

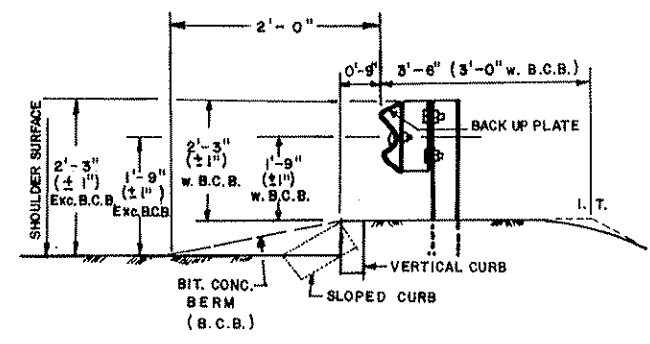
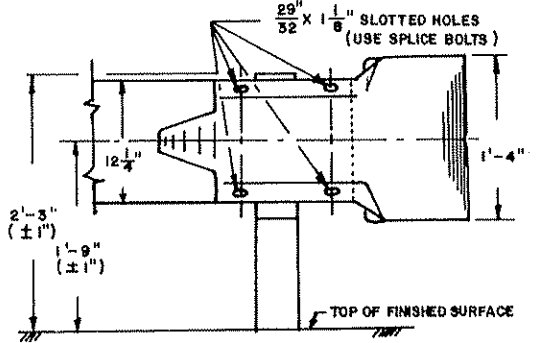

TYPICAL PLACEMENT SECTION

T	MASSACHUSETTS BAY TRANSPORTATION AUTHORITY	RAILROAD OPERATIONS	DWG. NO. 4056
			Nov. 17, 1986
			ISSUE NO. 1

STEEL BEAM GUARD RAIL DETAIL

Daniel Brown ENGINEERING OFFICER *W.A. McPherson* CHIEF ENGINEERING OFFICER