



**Massachusetts Bay
Transportation Authority**

GM Report to the Board

Phil Eng, MBTA General Manager and CEO

March 28, 2024





Blue Line, March 22

Broken Hanger





Red Line March 23, 2024

Broadway South Crossover Switch

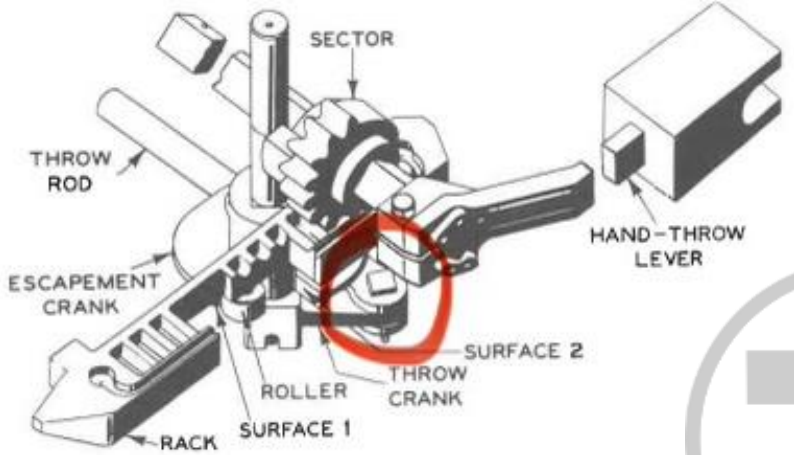
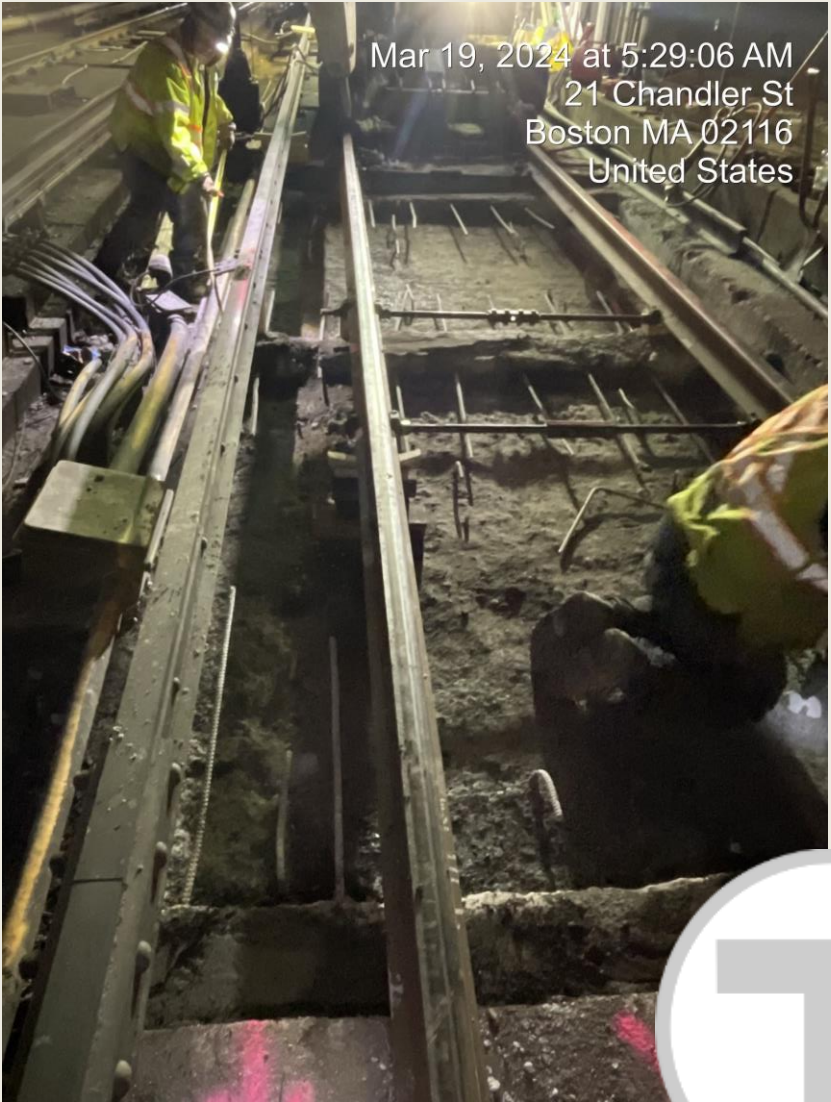
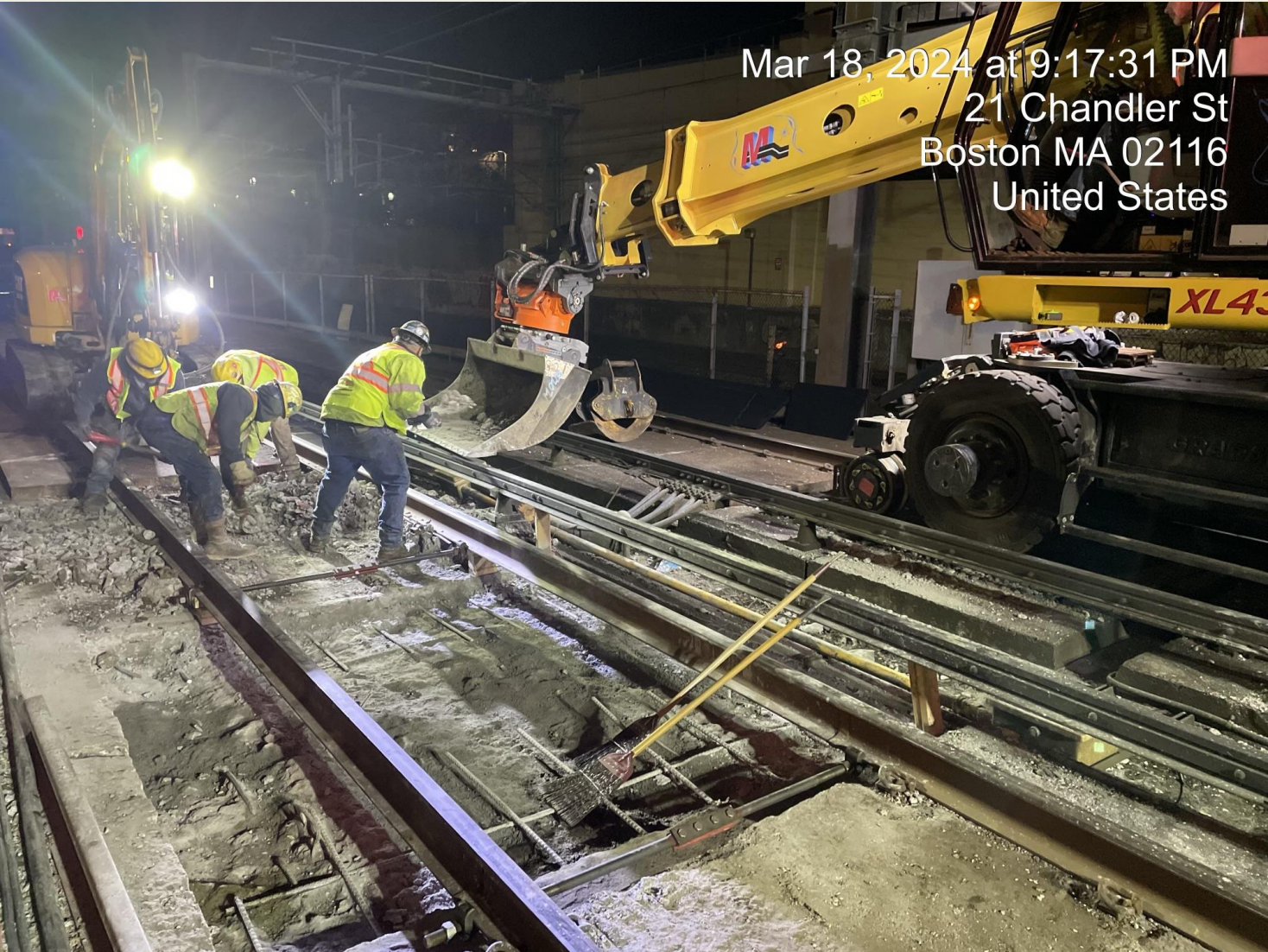

Figure 8. Switch-throw mechanism with hand-throw lever in normal



Orange Line Diversion

*North Station to Jackson Square
March 18-21*



Chinatown Station

Rail Rub Replacement

Station Improvements OL March 18-21

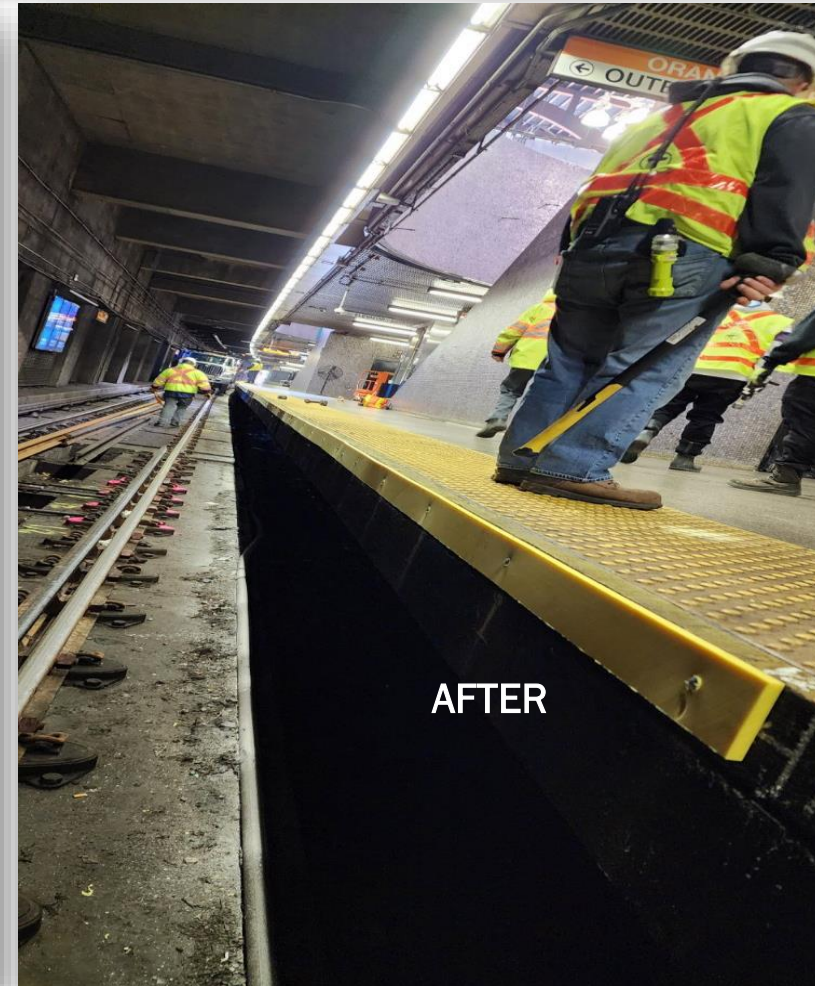
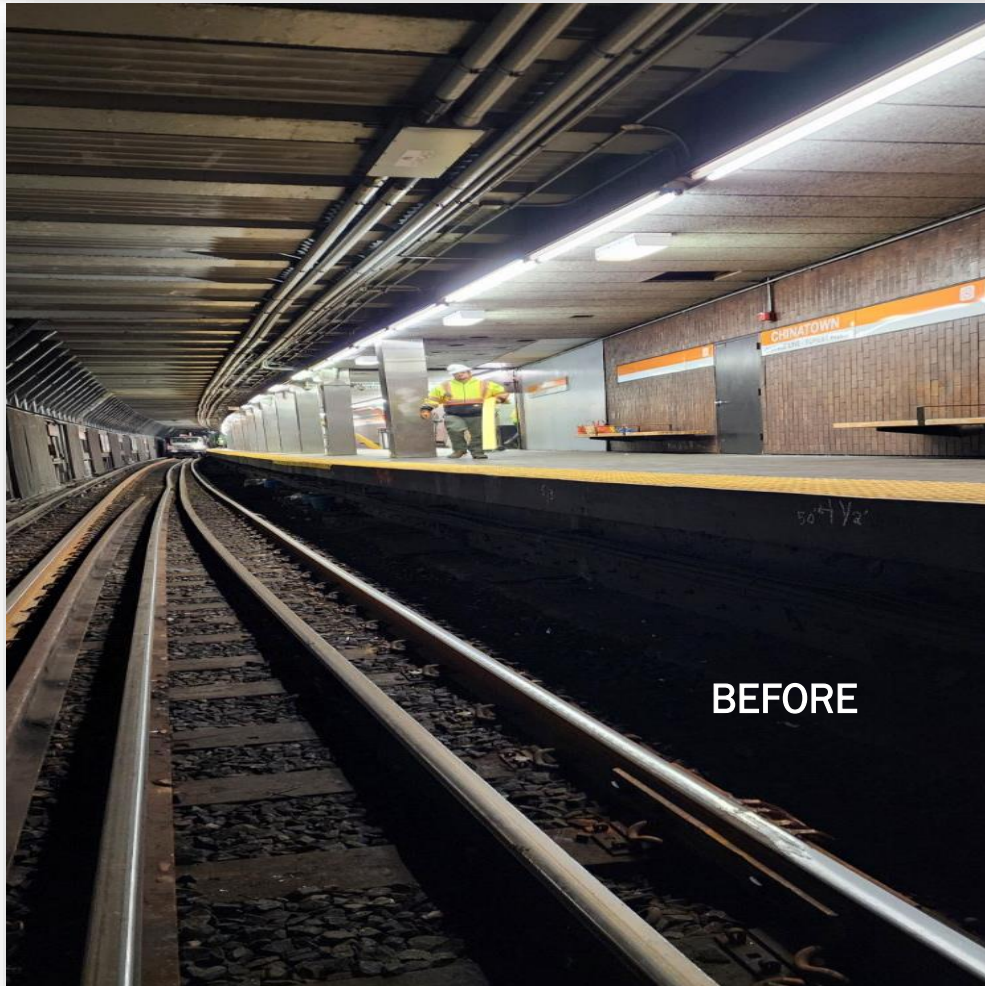

Ruggles Station Painting

Station Improvements OL March 18-21

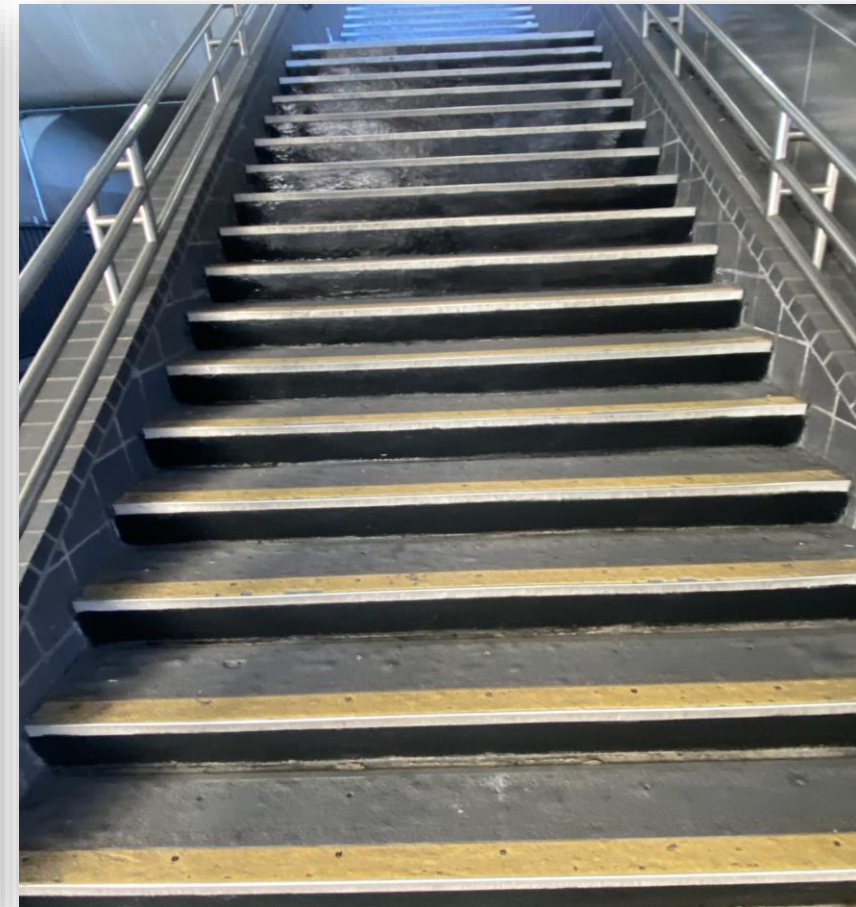

Copley, Kenmore, Hynes New Lexan - Maps

Station Improvements GL Feb 20 – Mar 8



Kenmore Station Ceiling Painting

Station Improvements GL Feb 20 – Mar 8



Dorchester Ave. Bridge Demo March 23-24

*Committed to
Rebuilding and
Reinforcing our
Infrastructures*

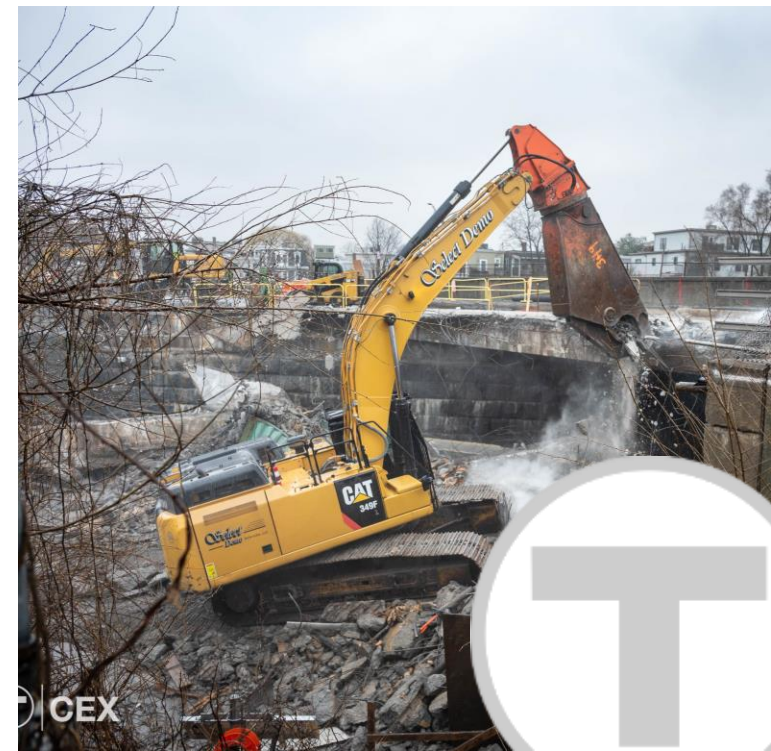
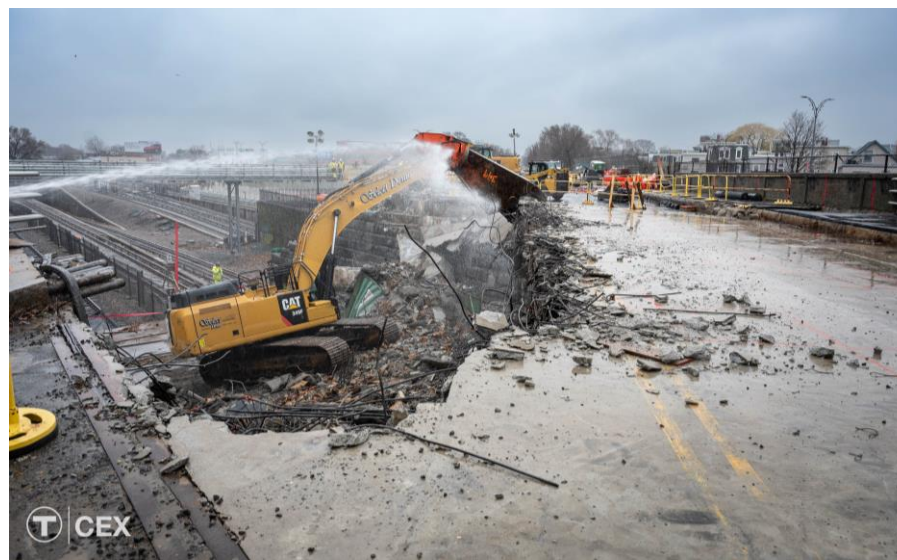



FTA Opens Public Comment on Proposed Rule to Strengthen Rail Transit Worker Safety



Commuter Rail Successor Contract RFI Underway



Battery Electric Multiple Units (BEMU) Innovation Proposal



Fairmount Line





St. Patrick's Day 2024 vs Typical Sunday.

- Total gated station entries increased **26%**.
- The Red Line increased **68%**.
- Andrew station entries increased **476%**.
- South Station increased **109%**.
- Broadway increased **230%**.





Rebuilding Our Workforce | Bus Operators





Rebuilding Our Workforce | GL Operators



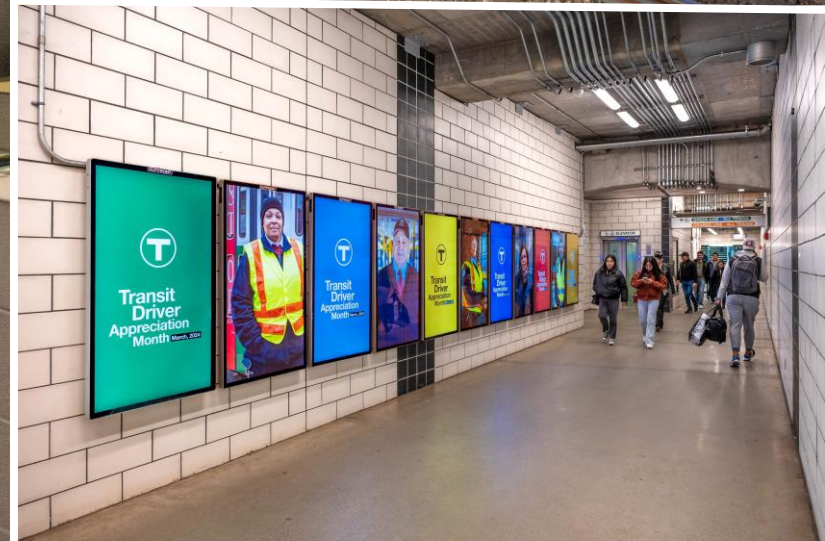

Transit Driver Appreciation Month

Celebrating Our Dedicated Motor Persons





CEX Launches T Insights

Promoting Employee Engagement





Women's History Month

*Celebrating women
and their contributions*

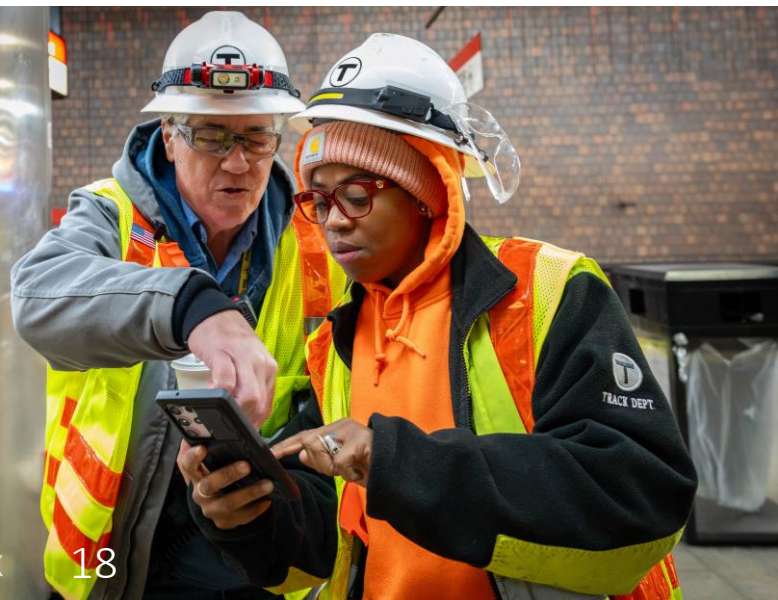

Horace Mann Students Visit T Training Center

Applying learning to real-life experience





Horace Mann Students Visit T Training Center





Ocean (Tao) Luo

MBTA Sr. Asset Planning Manager

Named a 2024 Transformative Justice Fellow



Marking the beginning of a journey to understand federal policy and funding opportunities to address racial equity and to share ideas with federal staff.

